

MARCH 2026 PRICE LIST

Worksurfaces

PRODUCT INFORMATION

Universal Worksurfaces Statement of Line 3
Universal Worksurface Finish Options 4
Universal Worksurfaces Product Details 5
Universal Worksurfaces Grommet Specifications 7

Worksurfaces

Rectangular Worksurfaces 9
Rectangular Worksurfaces for Height Adjustable Tables 11
System Specific Extended Rectangular Worksurfaces 12
System Specific Bullpen Surfaces 13
Radius Rectangle Surfaces 14
Rectilinear and Extended Rectilinear Corners 15
Curvilinear Corners 16
Cockpit Corners. 17
Extended Curvilinear Corner Worksurfaces. 18
D-Tops 24
P Top Surfaces 25
System Specific Spanner Half Moons 26
Rounds and 120° Corners 27
Shelf Surfaces and Rectangular / Radius Transactions. 28
Grommet Hole Covers 29

WARRANTY & TERMS AND CONDITIONS

For Warranty & Terms and Conditions please visit:

<https://www.ais-inc.com>

WORKSURFACES

2MM EDGE WORKSURFACES

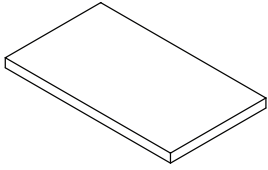

Rectangular Worksurfaces

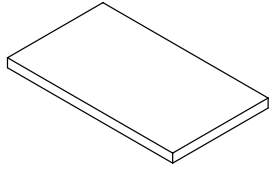

Extended Rectangular Worksurfaces
System Specific

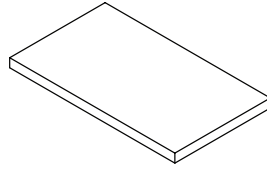

Bullpen Surfaces
System Specific

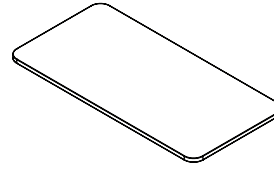

Radius Rectangle Surfaces

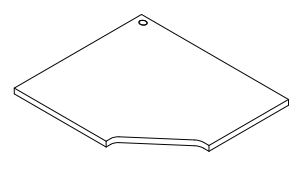

Standard Rectilinear Corners Type B

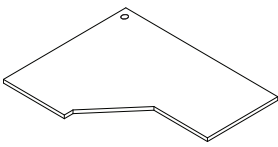

Extended Rectilinear Corners
Left or Right Hand

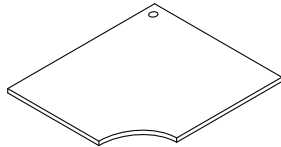

Curvilinear Corners Type A

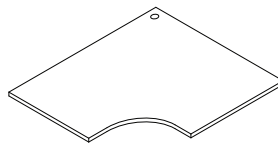

Standard Curvilinear Corners Type B

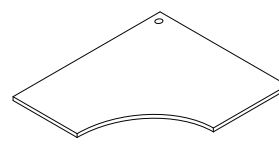

Cockpit Corner

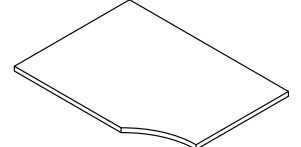

Cockpit Corner Returns
Left or Right Hand

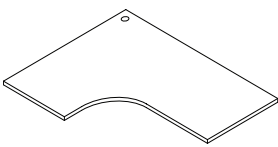

Extended Curvilinear Corners
Left or Right Hand

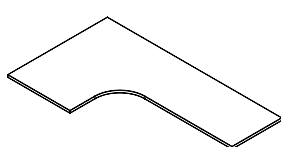

Depth Transition Curvilinear Corners

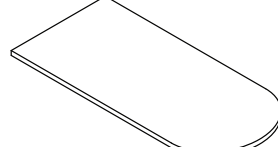

D-Top

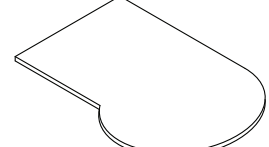

P-Top
Left or Right Hand

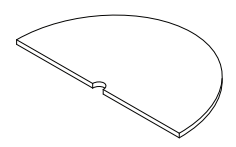

Spanner Half Moons
System Specific

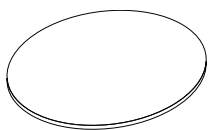

Rounds

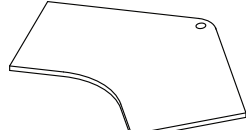

Standard 120° C, 90° L, 90° R Corner

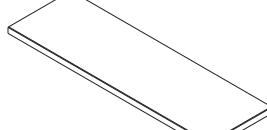

Shelf Surface

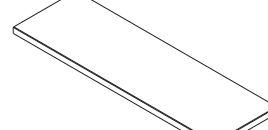

Rectangular Transaction

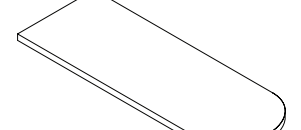

Radius Transaction

Worksurface Laminate Options

WORKSURFACE LAMINATE OPTIONS	
Name	Grade
Absolute Acajou	A
Aimtoo Savatre	A
Black	A
Brazilwood	A
Chalk	A
Corporate Walnut	A
Dark Rum Cherry	A
Field Elm	A
Grand Cherry	A
Grey Elm	A
Landmark	A
Leave Likatre	A
Linen	A
Looks Likatre	A
Maritime Dune	A
Midwest Maple	A
Neo Walnut	A
Phantom Ecrú	A
Phantom Pearl	A
Storm	A
Summer Drops	A
True White	A
Trytoo Savatre	A
White Chocolate	A
Asian Night	B
Asian Sand	B
Beige Granite	B
Colombian Walnut	B

WORKSURFACE LAMINATE OPTIONS	
Name	Grade
Fonthill Pear	B
Grey Mesh	B
Gridlock in L.A.	B
Madagascar	B
Mahogany Clove	B
Monticello Maple	B
Nightfall	B
Paris White Potteryware	B
Pewter Mesh	B
Recon Oak	B
Shadow	B
Sunset	B
Titanium EV	B
Tungsten EV	B
White Spektrum	B
Windswept Pewter	B
Yorkshire Cherry	B
Ebony	C
Bright White (Writable Surface)	C
Pecan Woodline	C
Strand Burnt	C
Strand Wenge	C
Strand Wheat	C
Twill Earthen	C
Twill Graphite	C
Twill Sarum	C
Warm White	C

EDGE BAND OPTIONS		
Name	Color Code	Grade
Absolute Acajou	AA	A
Aimtoo Savatre	AS	A
Black	BK	A
Brazilwood	BZ	A
Chalk	CK	A
Corporate Walnut	CT	A
Dark Rum Cherry	DR	A
Dark Tone	DT	A
Field Elm	FE	A
Grand Cherry	GC	A
Grey Elm	GE	A
Grey Value 1	GV1	A
Landmark	LM	A
Leave Likatre	LV	A

EDGE BAND OPTIONS		
Name	Color Code	Grade
Light Tone	LT	A
Linen	LN	A
Looks Likatre	LK	A
Maritime Dune	MD	A
Medium Tone	MT	A
Midwest Maple	MM	A
Neo Walnut	NW	A
Phantom Ecrú	PE	A
Phantom Pearl	PP	A
Satin White / True White	SW/TW	A
Storm	ST	A
Summer Drops	SD	A
Trytoo Savatre	TS	A
White Chocolate	WC	A

Custom Edgeband Options

- Custom match non-standard edgebands must be submitted as a special. Pricing varies based on edge thickness and finish.
- Minimum order size for any custom color is \$75,000.00 list. Extended lead-time will apply.

At AIS, we take great pride in offering a diverse selection of high-quality materials including but not limited to textiles, laminates, PET, mesh, etc. However, AIS cannot guarantee uniformity in dye lots across different production runs. As such, AIS is not liable for any variations in dye lots or color discrepancies in any of our products that may occur between orders. We encourage customers to review samples for color and texture matching prior to purchase. We are committed to providing exceptional products and are confident that our selection of textiles will meet your expectations for both aesthetic appeal and durability.

Universal Worksurfaces Product Details

Product Detail 1
2mm Edge Details

2 mm edge banding (approximately 3/32") is made of flexible, dent resistant ABS. Impregnated colors match panel trim colors and help to reduce visible scratches. Edges are rounded/beveled for comfort. 2mm edging is available on all worksurface shapes. All surfaces shown are 2mm unless noted otherwise.

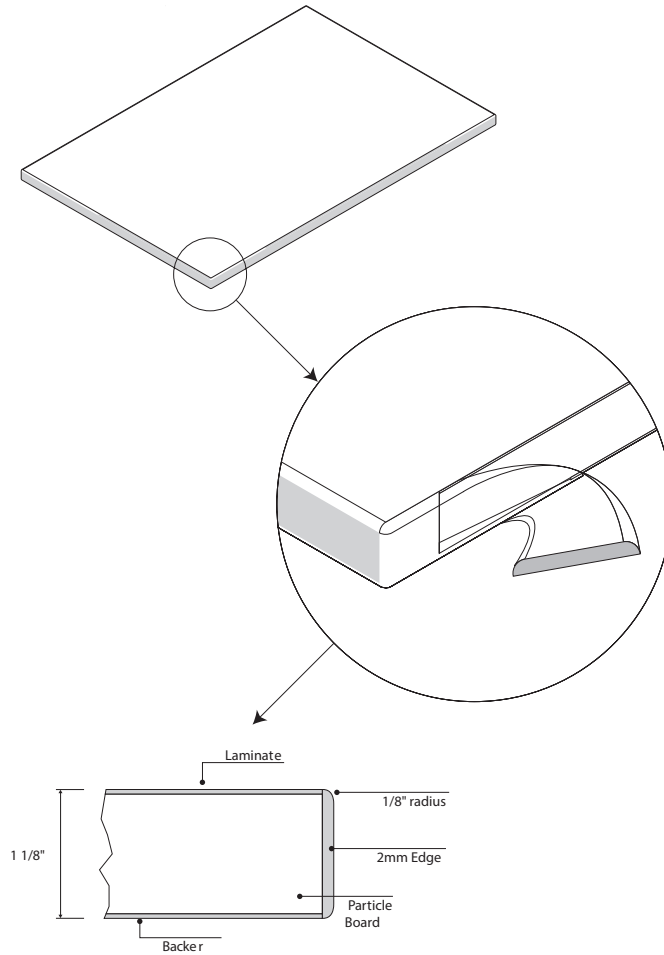

Universal Worksurfaces Product Details

Product Detail 2
Worksurfaces for Height Adjustable Tables

Worksurfaces for Height Adjustable Tables require a 1" gap on all sides to prevent pinch points. When placing two Worksurfaces for Height Adjustable Tables side-by-side each worksurface requires the 1" gap resulting in a 2" gap between worksurfaces. See examples below.

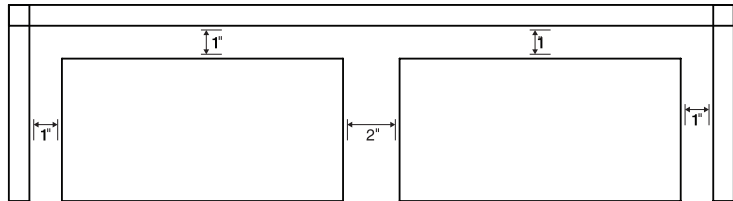
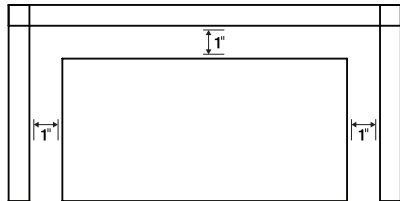

Product Detail 3
Curvilinear Corner Part Number Nomenclature

Curvilinear Corner part numbers are read from the seated position starting on the left and reading clockwise regardless of handedness.

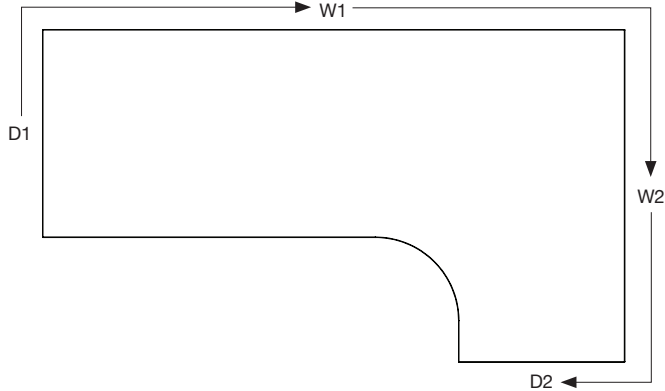
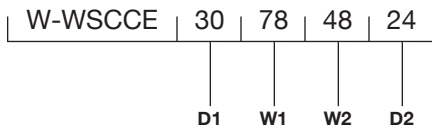

Universal Worksurfaces Grommet Specifications

RECTANGULAR GROMMET OPTIONS

Option	Location	List
A	No Grommets	-
B	Location 1	+38
C	Location 2	+38
D	Location 3	+38
E	Locations 2 and 3	+76
F	Locations 1, 2 and 3	+114
G	Locations 1 and 2	+76
H	Locations 1 and 3	+76
I	Location 4	+38
J	Location 5	+38
K	Locations 4 and 5	+76
L	Locations 1, 4 and 5	+114
M	Locations 1 and 4	+76
N	Locations 1 and 5	+76

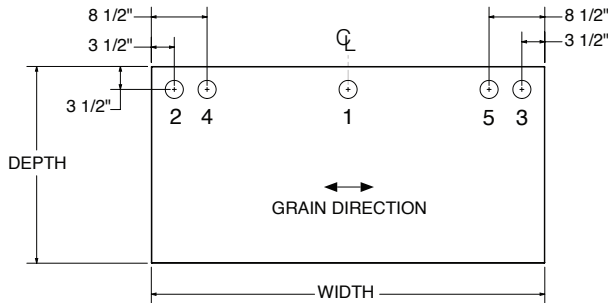

Applies to: Rectangulars, Extended Rectangulars, Cockpit Returns, 120° Returns

CORNER GROMMET OPTIONS

Option	Location	List
A	No Grommets	-
B	Location 1 (Default)	-
C	Location 1 and 2	+38
D	Location 1 and 3	+38
E	Locations 1, 2 and 3	+76

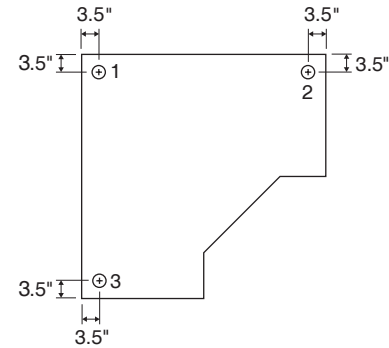

Applies to: All Corners (Rectilinear, Curvilinear, Depth Transitions, Cockpit Corners, 120° Corners, 135° Corners, Corner Keyboards)

RADIUS RECTANGULAR OPTIONS

Option	Location	List
A	No Grommets	-
B	Location 1	+38

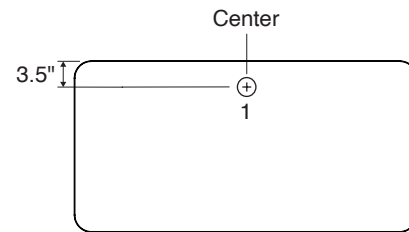

Applies to: Freestanding use only

Notes

- Grommet holes are 2 3/4" outside diameter with a 2 5/8" inside diameter (inside sleeve).
- Grommet covers are available in either grey or black and are included with grommet options.
- Grommet covers may also be purchased separately.
- Specification tip:
 - Options 1, 2 and 3 for use with panel systems.
 - Options 1, 4 and 5 for use with freestanding supports.

Grommet Specifications

EXTENDED LEFT HAND CORNER GROMMET OPTIONS

Option	Location	List
A	No Grommets	-
B	Location 1 (Default)	-
C	Location 1 and 2	+38
D	Location 1 and 4	+38
E	Locations 1 and 3*	+38
F	Locations 1, 2 and 4	+76
G	Locations 1, 3 and 4*	+76

*Available on 72" Wide only.

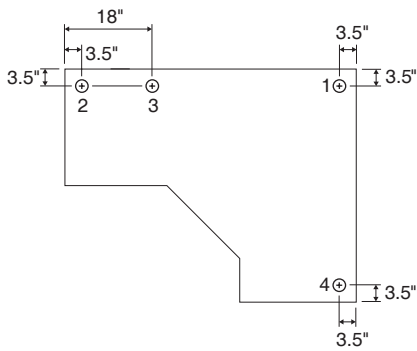

Applies to: All Extended Left Hand Corners (Rectilinears, Curvilinears, Depth Transitions, 120° Corners, 135° Corners). Excludes all Extended D-Tops.

EXTENDED RIGHT HAND CORNER GROMMET OPTIONS

Option	Location	List
A	No Grommets	-
B	Location 1 (Default)	-
C	Location 1 and 2	+38
D	Location 1 and 4	+38
E	Locations 1 and 3*	+38
F	Locations 1, 2 and 4	+76
G	Locations 1, 3 and 4*	+76

*Available on 72" Wide only.

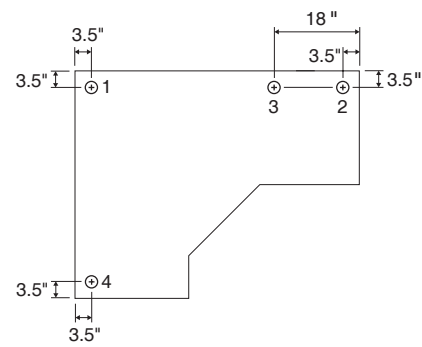

Applies to: All Extended Right Hand Corners (Rectilinears, Curvilinears, Depth Transitions, 120° Corners, 135° Corners). Excludes all Extended D-Tops.

D-TOP GROMMET OPTIONS

Option	Location	List
A	No Grommets	-
B	Location 1	+38
C	Location 2	+38
D	Locations 1 and 2	+76

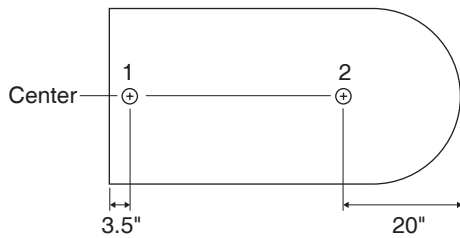

Applies to: D-Tops

P-TOP GROMMET OPTIONS

Option	Location	List
A	No Grommets	-
B	Location 1	+38
C	Location 2	+38
D	Locations 1 and 2	+76

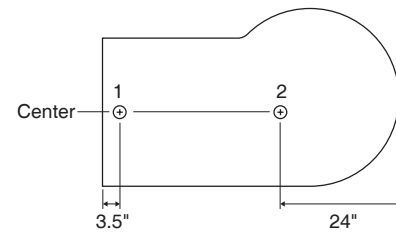

Applies to: P-Tops

Notes

- Grommet holes are 2 3/4" outside diameter with a 2 5/8" inside diameter (inside sleeve).
- Grommet covers are available in either grey or black and are included with grommet options.
- Grommet covers may also be purchased separately.

Rectangular Worksurfaces

18" DEEP RECTANGULAR WORKSURFACES

D	W	Model Number	List	Grade C Laminate
18	18	W-WS1818	385	+21
18	24	W-WS1824	418	+21
18	30	W-WS1830	503	+28
18	36	W-WS1836	544	+28
18	42	W-WS1842	593	+30
18	48	W-WS1848	643	+33
18	54	W-WS1854	717	+41
18	60	W-WS1860	792	+41
18	66	W-WS1866	900	+46
18	72	W-WS1872	931	+51
18	78	W-WS1878	1,051	+58
18	84	W-WS1884	1,124	+58
18	90	W-WS1890	1,184	+68
18	96	W-WS1896	1,316	+68

24" DEEP RECTANGULAR WORKSURFACES

D	W	Model Number	List	Grade C Laminate
24	24	W-WS2424	424	+21
24	30	W-WS2430	506	+25
24	36	W-WS2436	551	+28
24	42	W-WS2442	598	+30
24	48	W-WS2448	649	+33
24	54	W-WS2454	721	+41
24	60	W-WS2460	796	+41
24	66	W-WS2466	904	+46
24	72	W-WS2472	989	+51
24	78	W-WS2478	1,056	+54
24	84	W-WS2484	1,130	+58
24	90	W-WS2490	1,145	+68
24	96	W-WS2496	1,320	+68

30" DEEP RECTANGULAR WORKSURFACES

D	W	Model Number	List	Grade C Laminate
30	24	W-WS3024	506	+25
30	30	W-WS3030	595	+30
30	36	W-WS3036	648	+34
30	42	W-WS3042	768	+39
30	48	W-WS3048	831	+42
30	54	W-WS3054	964	+50
30	60	W-WS3060	964	+50
30	66	W-WS3066	1,087	+56
30	72	W-WS3072	1,182	+61
30	78	W-WS3078	1,432	+69
30	84	W-WS3084	1,665	+87
30	90	W-WS3090	1,691	+96
30	96	W-WS3096	1,844	+96

36" DEEP RECTANGULAR WORKSURFACES

D	W	Model Number	List	Grade C Laminate
36	24	W-WS3624	551	+28
36	30	W-WS3630	666	+34
36	36	W-WS3636	779	+40
36	42	W-WS3642	967	+50
36	48	W-WS3648	1,038	+53
36	54	W-WS3654	1,187	+61
36	60	W-WS3660	1,314	+68
36	66	W-WS3666	1,385	+72
36	72	W-WS3672	1,541	+80
36	78	W-WS3678	1,703	+88
36	84	W-WS3684	1,845	+96
36	90	W-WS3690	1,888	+99
36	96	W-WS3696	2,048	+99

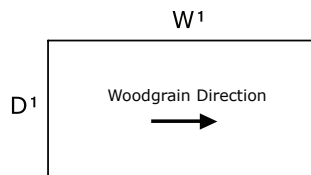

Specify

- Laminate Selection
- Color Selection for 2mm Edge
- Additional Grommet Locations (+38)
- Grommet Cover Color (if applicable)

Notes

- Worksurface support hardware is specified separately.
- Grommet holes with covers are specified as options.
- It is highly recommended that a center support be used on all worksurfaces greater than 48" width.
- When spanning panel connections with a worksurface greater than 48" wide, an additional center cantilever is recommended for added support. Otherwise, a U-channel is recommended for additional center worksurface support.
- It is not recommended that 36", 42" and 48" deep worksurfaces be cantilevered to panels.
- If these size depths must be panel hung, it is highly recommended that an additional front support, such as a combination leg or full laminate support panel, also be specified.

Rectangular Worksurfaces

42" DEEP RECTANGULAR WORKSURFACES

D	W	Model Number	List	Grade C Laminate
42	24	W-WS4224	569	+30
42	30	W-WS4230	695	+39
42	36	W-WS4236	817	+50
42	42	W-WS4242	1,009	+52
42	48	W-WS4248	1,078	+57
42	54	W-WS4254	1,240	+63
42	60	W-WS4260	1,540	+67
42	66	W-WS4266	1,445	+68
42	72	W-WS4272	1,617	+77
42	84	W-WS4284	1,928	+96
42	90	W-WS4290	2,109	+99
42	96	W-WS4296	1,984	+99

48" DEEP RECTANGULAR WORKSURFACES

D	W	Model Number	List	Grade C Laminate
48	24	W-WS4824	649	+33
48	30	W-WS4830	831	+42
48	36	W-WS4836	1,038	+53
48	42	W-WS4842	1,103	+57
48	48	W-WS4848	1,165	+60
48	54	W-WS4854	1,312	+68
48	60	W-WS4860	1,298	+67
48	66	W-WS4866	1,445	+75
48	72	W-WS4872	1,480	+77
48	84	W-WS4884	1,857	+97
48	90	W-WS4890	2,069	+99
48	96	W-WS4896	1,912	+99

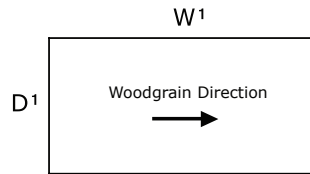

Specify	Notes
<ul style="list-style-type: none"> • Laminate Selection • Color Selection for 2mm Edge • Additional Grommet Locations (+38) • Grommet Cover Color (if applicable) 	<ul style="list-style-type: none"> • Worksurface support hardware is specified separately. • Grommet holes with covers are specified as options. • It is highly recommended that a center support be used on all worksurfaces greater than 48" width. • When spanning panel connections with a worksurface greater than 48" wide, an additional center cantilever is recommended for added support. Otherwise, a U-channel is recommended for additional center worksurface support. • It is not recommended that 36", 42" and 48" deep worksurfaces be cantilevered to panels. • If these size depths must be panel hung, it is highly recommended that an additional front support, such as a combination leg or full laminate support panel, also be specified.

Rectangular Worksurfaces for Height Adjustable Tables

RECTANGULAR WORKSURFACES FOR HEIGHT ADJUSTABLE TABLES

D ¹	W ¹	Model Number	List
23	46	W-WS2346	649
23	52	W-WS2352	750
23	58	W-WS2358	796
23	64	W-WS2364	904
23	70	W-WS2370	989
29	46	W-WS2946	831
29	52	W-WS2952	853
29	58	W-WS2958	964
29	64	W-WS2964	1,087
29	70	W-WS2970	1,182

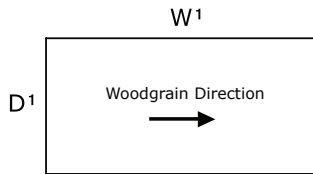

Specify	Notes
<ul style="list-style-type: none"> • Laminate Selection • Color Selection for 2mm Edge • Grommet Location • Color Selection for Grommet Cover 	<ul style="list-style-type: none"> • Rectangular Worksurfaces for Height Adjustable Tables have a 1 1/8" thickness. • Height adjustable worksurface support base is specified separately. • Grommet holes with covers are specified as options. • These worksurfaces are for use with height adjustable table bases only. • Worksurfaces for Height Adjustable Tables require a 1" gap around to prevent pinch points. See example in Product Details.

System Specific Extended Rectangular Worksurfaces

! The following worksurface is designed for use with Matrix systems only:

! The following worksurface is designed for use with Matrix systems only:

MATRIX SYSTEM EXTENDED RECTANGULAR WORKSURFACE

DIVI SYSTEM EXTENDED RECTANGULAR WORKSURFACE

D	W	Model Number	List	Grade C Laminate
24	27 1/4	W-WSE2424MX	429	+23
24	33 1/4	W-WSE2430MX	513	+28
24	39 1/4	W-WSE2436MX	557	+30
24	45 1/4	W-WSE2442MX	610	+33
24	51 1/4	W-WSE2448MX	664	+36
24	57 1/4	W-WSE2454MX	746	+41
24	63 1/4	W-WSE2460MX	814	+45
24	69 1/4	W-WSE2466MX	927	+51
24	75 1/4	W-WSE2472MX	1,011	+56
24	87 1/4	W-WSE2484MX	1,159	+64
30	27 1/4	W-WSE3024MX	572	+31
30	33 1/4	W-WSE3030MX	607	+33
30	39 1/4	W-WSE3036MX	675	+37
30	45 1/4	W-WSE3042MX	742	+41
30	51 1/4	W-WSE3048MX	800	+44
30	57 1/4	W-WSE3054MX	930	+51
30	63 1/4	W-WSE3060MX	989	+54
30	69 1/4	W-WSE3066MX	1,115	+62
30	75 1/4	W-WSE3072MX	1,207	+67
30	87 1/4	W-WSE3084MX	1,585	+88

D	W	Model Number	List	Grade C Laminate
24	26 3/16	W-WSE2424MW	457	+23
24	32 3/16	W-WSE2430MW	551	+28
24	38 3/16	W-WSE2436MW	595	+30
24	44 3/16	W-WSE2442MW	652	+33
24	50 3/16	W-WSE2448MW	708	+36
24	56 3/16	W-WSE2454MW	796	+41
24	62 3/16	W-WSE2460MW	869	+45
24	68 3/16	W-WSE2466MW	990	+51
24	74 3/16	W-WSE2472MW	1,079	+56
24	86 3/16	W-WSE2484MW	1,235	+64
30	26 3/16	W-WSE3024MW	610	+31
30	32 3/16	W-WSE3030MW	649	+33
30	38 3/16	W-WSE3036MW	719	+37
30	44 3/16	W-WSE3042MW	793	+41
30	50 3/16	W-WSE3048MW	853	+44
30	56 3/16	W-WSE3054MW	991	+51
30	62 3/16	W-WSE3060MW	1,054	+54
30	68 3/16	W-WSE3066MW	1,188	+62
30	74 3/16	W-WSE3072MW	1,291	+67
30	86 3/16	W-WSE3084MW	1,694	+88

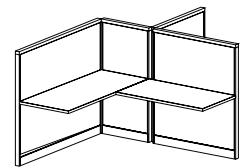
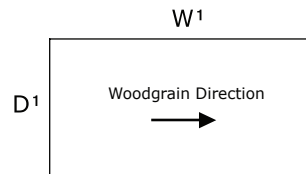
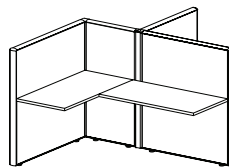
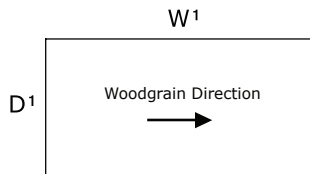

Specify

Notes

- Laminate Selection
- Color Selection for 2mm Edge
- Additional Grommet Locations (+38)
- Grommet Cover Color (if applicable)

- Worksurface support hardware is specified separately.
- Grommet holes with covers are specified as options.
- Extended rectangulars are designed to compensate for the gap created when a panel is inserted into a panel run at a 3-way connection.
- Be sure to order worksurface that corresponds to the system you are specifying.
- It is highly recommended that a center support be used on all worksurfaces greater than 48" wide.
- When spanning panel connections with a worksurface greater than 48" wide, an additional center cantilever is recommended for added support. Otherwise a U-Channel is recommended for additional center worksurface support.

System Specific Bullpen Surfaces

⚠ The following worksurface is designed for use with Divi systems only:

DIVI BULLPEN SURFACES					
D	W	Number of Panels	Model Number	List	Grade C Laminate
24	24 1/8	1	W-WSDV2424	454	+21
24	30 1/8	1	W-WSDV2430	532	+25
24	36 1/8	1	W-WSDV2436	579	+28
24	42 1/8	1	W-WSDV2442	629	+30
24	48 1/8	1	W-WSDV2448	677	+33
24	54 1/4	2	W-WSDV2454	828	+41
24	60 1/8	1	W-WSDV2460A	828	+41
24	60 1/4	2	W-WSDV2460B	828	+41
24	66 1/4	2	W-WSDV2466	935	+46
24	72 1/4	2	W-WSDV2472A	1,014	+51
24	72 3/8	3	W-WSDV2472B	1,014	+51
24	78 1/4	2	W-WSDV2478A	1,087	+54
24	78 3/8	3	W-WSDV2478B	1,087	+54
24	84 1/4	2	W-WSDV2484A	1,160	+58
24	84 3/8	3	W-WSDV2484B	1,160	+58

⚠ The following worksurface is designed for use with Divi systems only:

DIVI BULLPEN SURFACES					
D	W	Number of Panels	Model Number	List	Grade C Laminate
30	24 1/8	1	W-WSDV3024	532	+25
30	30 1/8	1	W-WSDV3030	626	+30
30	36 1/8	1	W-WSDV3036	698	+34
30	42 1/8	1	W-WSDV3042	795	+39
30	48 1/8	1	W-WSDV3048	854	+42
30	54 1/4	2	W-WSDV3054	997	+42
30	60 1/8	1	W-WSDV3060A	997	+50
30	60 1/4	2	W-WSDV3060B	997	+50
30	66 1/4	2	W-WSDV3066	1,118	+58
30	72 1/4	2	W-WSDV3072A	1,216	+61
30	72 3/8	3	W-WSDV3072B	1,216	+61
30	78 1/4	2	W-WSDV3078A	1,465	+69
30	78 3/8	3	W-WSDV3078B	1,465	+69
30	84 1/4	2	W-WSDV3084A	1,696	+87
30	84 3/8	3	W-WSDV3084B	1,696	+87

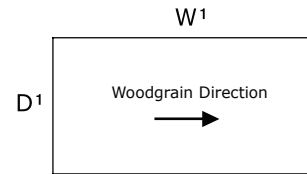
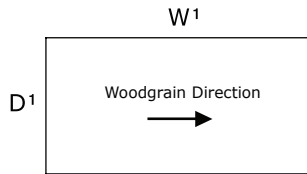

Specify

Notes

- Laminate Selection
- Color Selection for 2mm Edge
- Additional Grommet Locations (+38)
- Grommet Cover Color (if applicable)

- Worksurface support hardware is specified separately.
- Grommet holes with covers are specified as options.
- Bullpen Rectangular surfaces are designed to compensate for the gap created by natural panel creep for system specific (MWall or Divi) panels only.
- It is highly recommended that a center support be used on all workspaces greater than 48" wide.
- When spanning panel connections with a worksurface greater than 48" wide, an additional center cantilever is recommended for added support. Otherwise a U-Channel is recommended for additional center worksurface support.

Radius Rectangle Surfaces

RADIUS RECTANGLE WORKSURFACES				
D'	W'	Model Number	List	Grade C Laminate
24	24	W-W4C2424	663	+110
24	30	W-W4C2430	744	+110
24	36	W-W4C2436	789	+110
24	42	W-W4C2442	838	+110
24	48	W-W4C2448	888	+110
24	54	W-W4C2454	963	+200
24	60	W-W4C2460	1,035	+200
24	66	W-W4C2466	1,144	+200
24	72	W-W4C2472	1,229	+200
30	30	W-W4C3030	833	+200
30	36	W-W4C3036	887	+200
30	42	W-W4C3042	1,006	+200
30	48	W-W4C3048	1,069	+200
30	54	W-W4C3054	1,203	+240
30	60	W-W4C3060	1,203	+240
30	66	W-W4C3066	1,326	+240
30	72	W-W4C3072	1,422	+240

RADIUS RECTANGLE WORKSURFACES FOR HEIGHT ADJUSTABLE TABLES				
D'	W'	Model Number	List	Grade C Laminate
23	46	W-W4C2346	888	+110
23	52	W-W4C2352	990	+200
23	58	W-W4C2358	1,035	+200
23	64	W-W4C2364	1,144	+200
23	70	W-W4C2370	1,229	+200
29	46	W-W4C2946	1,069	+240
29	52	W-W4C2952	1,091	+240
29	58	W-W4C2958	1,203	+240
29	64	W-W4C2964	1,326	+240
29	70	W-W4C2970	1,422	+240

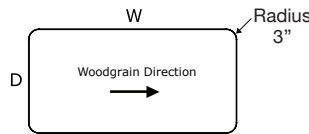

Specify

Notes

- Laminate Selection
- Color Selection for 2mm Edge
- Additional Grommet Locations (+38)
- Grommet Cover Color (if applicable)

- Worksurface support hardware is specified separately.
- Grommet holes with covers are specified as options.
- Height adjustable worksurface support base is specified separately. AIS height adjustable bases are only compatible with radius rectangle worksurfaces 48"W and larger.

Rectilinear and Extended Rectilinear Corners

EXTENDED RECTILINEAR LEFT HAND CORNERS

D ¹	W ¹	W ²	F	Model Number	List	Grade C Laminate
24	36	42	17	W-WSCE244236	950	+50
24	36	48	17	W-WSCE244836	955	+51
24	36	60	17	W-WSCE246036	1,115	+59
24	36	72	17	W-WSCE247236	1,555	+83
24	42	48	21.25	W-WSCE244842	1,160	+61
24	42	60	21.25	W-WSCE246042	1,366	+72
24	42	72	21.25	W-WSCE247242	1,574	+83
24	48	60	21.25	W-WSCE246048	1,371	+73
24	48	72	21.25	W-WSCE247248	1,577	+84

EXTENDED RECTILINEAR RIGHT HAND CORNERS

D ¹	W ¹	W ²	F	Model Number	List	Grade C Laminate
24	36	42	17	W-WSCE243642	950	+50
24	36	48	17	W-WSCE243648	955	+51
24	36	60	17	W-WSCE243660	1,115	+59
24	36	72	17	W-WSCE243672	1,555	+83
24	42	48	21.25	W-WSCE244248	1,160	+61
24	42	60	21.25	W-WSCE244260	1,366	+72
24	42	72	21.25	W-WSCE244272	1,574	+83
24	48	60	21.25	W-WSCE244860	1,371	+73
24	48	72	21.25	W-WSCE244872	1,577	+84

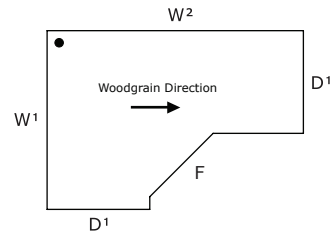
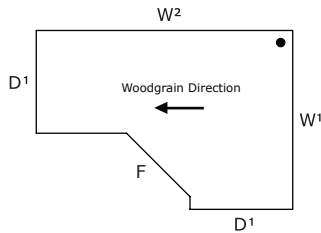

Specify

Notes

- Laminate Selection
- Color Selection for 2mm Edge
- Additional Grommet Locations (+38)
- Grommet Cover Color (if applicable)
- Worksurface support hardware is specified separately.
- Rear corner grommet hole with cover is included.
- Additional grommet holes with covers are specified as options.

STANDARD RECTILINEAR CORNER TYPE B

D ¹	W ¹	F	Model Number	List	Grade C Laminate
24	36	10.25	W-WSC2436B	872	+45
24	42	18.75	W-WSC2442B	1,049	+54
24	48	18.75	W-WSC2448	1,166	+60
30	42	10.25	W-WSC3042B	1,163	+60
30	48	18.75	W-WSC3048B	1,320	+69

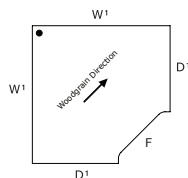

Specify

Notes

- Laminate Selection
- Color Selection for 2mm Edge
- Additional Grommet Locations (+38)
- Grommet Cover Color (if applicable)
- Worksurface support hardware is specified separately.
- Rear corner grommet hole with cover is included.
- Additional grommet holes with covers are specified as options.

Curvilinear Corners

CURVILINEAR CORNER TYPE A

D ¹	W ¹	Model Number	List	Grade C Laminate
24	36	W-WSCC2436	913	+47
30	42	W-WSCC3042	1,215	+63

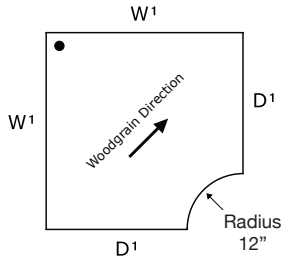

STANDARD CURVILINEAR CORNER TYPE B

D ¹	W ¹	Model Number	List	Grade C Laminate
24	42	W-WSCC2442	1,103	+58
24	48	W-WSCC2448	1,218	+64
30	48	W-WSCC3048	1,389	+72

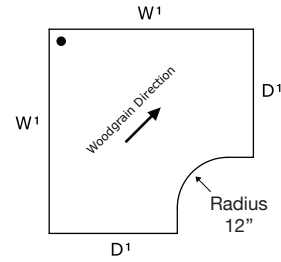

Specify

Notes

- | | |
|---|---|
| <ul style="list-style-type: none"> • Laminate Selection • Color Selection for 2mm Edge • Additional Grommet Locations (+38) • Grommet Cover Color (if applicable) | <ul style="list-style-type: none"> • Worksurface support hardware is specified separately. • Rear corner grommet hole with cover is included. • Additional grommet holes with covers are specified as options. |
|---|---|

Cockpit Corners

LEFT HAND COCKPIT CORNER RETURNS

D ¹	D ²	W ¹	Model Number	List	Grade C Laminate
24	30	36	W-WSCRL36	985	+54
24	30	42	W-WSCRL42	1,079	+60
24	30	48	W-WSCRL48	1,181	+66
24	30	60	W-WSCRL60	1,280	+71
24	30	66	W-WSCRL66	1,385	+77
24	30	72	W-WSCRL72	1,480	+83
24	30	84	W-WSCRL84	1,583	+88
24	30	96	W-WSCRL96	1,682	+94

RIGHT HAND COCKPIT CORNER RETURNS

D ¹	D ²	W ¹	Model Number	List	Grade C Laminate
24	30	36	W-WSCRR36	985	+54
24	30	42	W-WSCRR42	1,079	+60
24	30	48	W-WSCRR48	1,181	+66
24	30	60	W-WSCRR60	1,280	+71
24	30	66	W-WSCRR66	1,385	+77
24	30	72	W-WSCRR72	1,480	+83
24	30	84	W-WSCRR84	1,583	+88
24	30	96	W-WSCRR96	1,682	+94

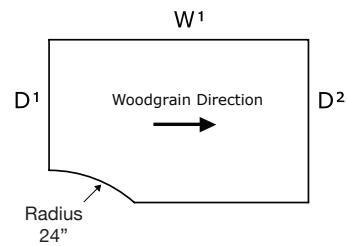
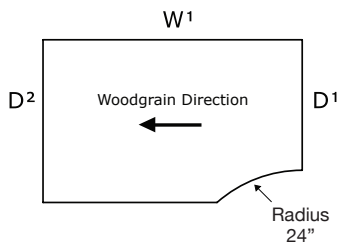

COCKPIT CORNER

D ¹	W ¹	Model Number	List	Grade C Laminate
24	48	W-WSCC48	1,240	+70

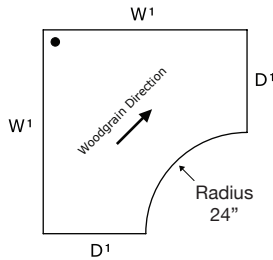

Specify

Notes

- | | |
|---|---|
| <ul style="list-style-type: none"> • Laminate Selection • Color Selection for 2mm Edge • Additional Grommet Locations (+38) • Grommet Cover Color (if applicable) | <ul style="list-style-type: none"> • Worksurface support hardware is specified separately. • Rear corner grommet hole with cover is included. • Additional grommet holes with covers are specified as options. |
|---|---|

Extended Curvilinear Corner Worksurfaces

NOMINAL SIZES – LEFT HAND					
D ¹	W ¹	W ²	Model Number	List	Grade C Laminate
24	42	36	W-WSCCE244236	999	+200
24	48	36	W-WSCCE244836	1,004	+200
24	54	36	W-WSCCE245436	1,308	+240
24	60	36	W-WSCCE246036	1,175	+240
24	66	36	W-WSCCE246636	1,407	+240
24	72	36	W-WSCCE247236	1,637	+240
24	78	36	W-WSCCE247836	1,651	+240
24	84	36	W-WSCCE248436	2,104	+240
24	48	42	W-WSCCE244842	1,216	+200
24	54	42	W-WSCCE245442	1,576	+240
24	60	42	W-WSCCE246042	1,430	+240
24	66	42	W-WSCCE246642	1,539	+240
24	72	42	W-WSCCE247242	1,647	+240
24	78	42	W-WSCCE247842	1,845	+240
24	84	42	W-WSCCE248442	1,825	+240
24	54	48	W-WSCCE245448	1,371	+240
24	60	48	W-WSCCE246048	1,444	+240
24	66	48	W-WSCCE246648	1,549	+240
24	72	48	W-WSCCE247248	1,653	+240
24	78	48	W-WSCCE247848	1,769	+240
24	84	48	W-WSCCE248448	1,884	+240

NOMINAL SIZES – RIGHT HAND					
D ¹	W ¹	W ²	Model Number	List	Grade C Laminate
24	36	42	W-WSCCE243642	999	+200
24	36	48	W-WSCCE243648	1,043	+200
24	36	54	W-WSCCE243654	1,089	+240
24	36	60	W-WSCCE243660	1,175	+240
24	36	66	W-WSCCE243666	1,406	+240
24	36	72	W-WSCCE243672	1,637	+240
24	36	78	W-WSCCE243678	1,651	+240
24	36	84	W-WSCCE243684	2,104	+240
24	42	48	W-WSCCE244248	1,216	+200
24	42	54	W-WSCCE244254	1,457	+240
24	42	60	W-WSCCE244260	1,430	+240
24	42	66	W-WSCCE244266	1,539	+240
24	42	72	W-WSCCE244272	1,647	+240
24	42	78	W-WSCCE244278	1,845	+240
24	42	84	W-WSCCE244284	1,825	+240
24	48	54	W-WSCCE244854	1,347	+240
24	48	60	W-WSCCE244860	1,444	+240
24	48	66	W-WSCCE244866	1,549	+240
24	48	72	W-WSCCE244872	1,653	+240
24	48	78	W-WSCCE244878	1,769	+240
24	48	84	W-WSCCE244884	1,884	+240

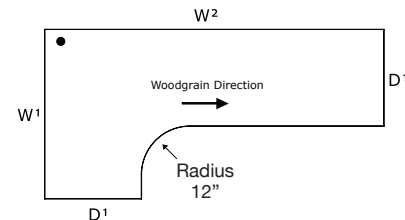
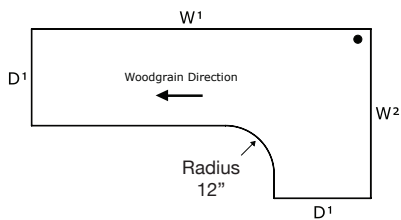

Specify

Notes

- Laminate Selection
- Color Selection for 2mm Edge
- Additional Grommet Locations (+38)
- Grommet Cover Color (if applicable)
- Worksurface support hardware is specified separately.
- Grommet holes with covers are specified as options.

Extended Curvilinear Corner Worksurfaces

NOMINAL SIZES – LEFT HAND					
D ¹	W ¹	W ²	Model Number	List	Grade C Laminate
30	48	42	W-WSCCE304842	1,395	+200
30	54	42	W-WSCCE305442	1,502	+240
30	60	42	W-WSCCE306042	1,609	+240
30	66	42	W-WSCCE306642	1,672	+240
30	72	42	W-WSCCE307242	1,826	+240
30	78	42	W-WSCCE307842	1,710	+240
30	84	42	W-WSCCE308442	1,783	+240
30	54	48	W-WSCCE305448	1,551	+240
30	60	48	W-WSCCE306048	1,636	+240
30	66	48	W-WSCCE306648	1,705	+240
30	72	48	W-WSCCE307248	1,831	+240
30	78	48	W-WSCCE307848	1,942	+240
30	84	48	W-WSCCE308448	2,039	+240

NOMINAL SIZES – RIGHT HAND					
D ¹	W ¹	W ²	Model Number	List	Grade C Laminate
30	42	48	W-WSCCE304248	1,395	+200
30	42	54	W-WSCCE304254	1,502	+240
30	42	60	W-WSCCE304260	1,406	+240
30	42	66	W-WSCCE304266	1,672	+240
30	42	72	W-WSCCE304272	1,826	+240
30	42	78	W-WSCCE304278	1,710	+240
30	42	84	W-WSCCE304284	1,931	+240
30	48	54	W-WSCCE304854	1,589	+240
30	48	60	W-WSCCE304860	1,636	+240
30	48	66	W-WSCCE304866	1,728	+240
30	48	72	W-WSCCE304872	1,831	+240
30	48	78	W-WSCCE304878	1,942	+240
30	48	84	W-WSCCE304884	2,039	+240

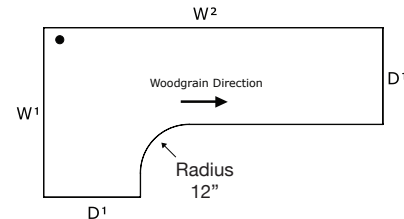
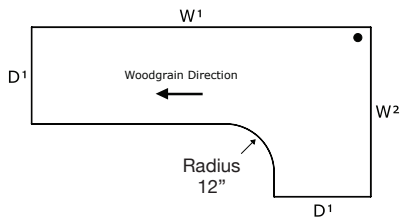

Specify

Notes

- Laminate Selection
- Color Selection for 2mm Edge
- Additional Grommet Locations (+38)
- Grommet Cover Color (if applicable)

- Worksurface support hardware is specified separately.
- Grommet holes with covers are specified as options.

Extended Curvilinear Corner Worksurfaces

DEPTH TRANSITION – LEFT HAND

D ¹	W ¹	W ²	D ²	Model Number	List	Grade C Laminate
24	48	42	30	W-WSCCE24484230	1,806	+200
24	54	42	30	W-WSCCE24544230	1,814	+240
24	60	42	30	W-WSCCE24604230	1,824	+240
24	66	42	30	W-WSCCE24664230	1,831	+240
24	72	42	30	W-WSCCE24724230	1,840	+240
24	78	42	30	W-WSCCE24784230	1,847	+240
24	84	42	30	W-WSCCE24844230	1,857	+240
24	54	48	30	W-WSCCE24544830	1,864	+240
24	60	48	30	W-WSCCE24604830	1,885	+240
24	66	48	30	W-WSCCE24664830	1,904	+240
24	72	48	30	W-WSCCE24724830	1,925	+240
24	78	48	30	W-WSCCE24784830	1,932	+240
24	84	48	30	W-WSCCE24844830	1,941	+240
30	48	42	24	W-WSCCE30484224	1,806	+200
30	54	42	24	W-WSCCE30544224	1,814	+240
30	60	42	24	W-WSCCE30604224	1,824	+240
30	66	42	24	W-WSCCE30664224	1,831	+240
30	72	42	24	W-WSCCE30724224	1,840	+240
30	78	42	24	W-WSCCE30784224	1,847	+240
30	84	42	24	W-WSCCE30844224	1,857	+240
30	54	48	24	W-WSCCE30544824	1,864	+240
30	60	48	24	W-WSCCE30604824	1,885	+240
30	66	48	24	W-WSCCE30664824	1,904	+240
30	72	48	24	W-WSCCE30724824	1,925	+240
30	78	48	24	W-WSCCE30784824	1,932	+240
30	84	48	24	W-WSCCE30844824	1,941	+240

DEPTH TRANSITION – RIGHT HAND

D ¹	W ¹	W ²	D ²	Model Number	List	Grade C Laminate
24	42	48	30	W-WSCCE24424830	1,806	+200
24	42	54	30	W-WSCCE24425430	1,814	+240
24	42	60	30	W-WSCCE24426030	1,824	+240
24	42	66	30	W-WSCCE24426630	1,831	+240
24	42	72	30	W-WSCCE24427230	1,840	+240
24	42	78	30	W-WSCCE24427830	1,847	+240
24	42	84	30	W-WSCCE24428430	1,857	+240
24	48	54	30	W-WSCCE24485430	1,864	+240
24	48	60	30	W-WSCCE24486030	1,885	+240
24	48	66	30	W-WSCCE24486630	1,904	+240
24	48	72	30	W-WSCCE24487230	1,925	+240
24	48	78	30	W-WSCCE24487830	1,932	+240
24	48	84	30	W-WSCCE24488430	1,941	+240
30	42	48	24	W-WSCCE30424824	1,806	+200
30	42	54	24	W-WSCCE30425424	1,814	+240
30	42	60	24	W-WSCCE30426024	1,824	+240
30	42	66	24	W-WSCCE30426624	1,710	+240
30	42	72	24	W-WSCCE30427224	1,840	+240
30	42	78	24	W-WSCCE30427824	1,847	+240
30	42	84	24	W-WSCCE30428424	1,857	+240
30	48	54	24	W-WSCCE30485424	1,864	+240
30	48	60	24	W-WSCCE30486024	1,885	+240
30	48	66	24	W-WSCCE30486624	1,710	+240
30	48	72	24	W-WSCCE30487224	1,925	+240
30	48	78	24	W-WSCCE30487824	1,932	+240
30	48	84	24	W-WSCCE30488424	1,941	+240

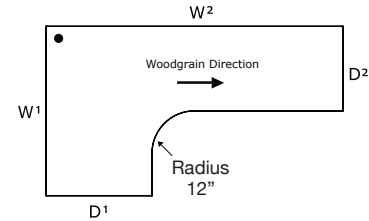
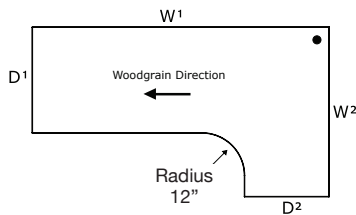

Specify

Notes

- Laminate Selection
- Color Selection for 2mm Edge
- Additional Grommet Locations (+38)
- Grommet Cover Color (if applicable)
- Worksurface support hardware is specified separately.
- Grommet holes with covers are specified as options.

Extended Curvilinear Corner Worksurfaces

HEIGHT ADJUSTABLE OFFSET SIZES – LEFT HAND

D ¹	W ¹	W ²	Model Number	List	Grade C Laminate
23	40	34	W-WSCCE234034	1,610	+200
23	46	34	W-WSCCE234634	1,669	+200
23	52	34	W-WSCCE235234	1,730	+240
23	58	34	W-WSCCE235834	1,789	+240
23	64	34	W-WSCCE236434	1,848	+240
23	70	34	W-WSCCE237034	1,733	+240
23	76	34	W-WSCCE237634	1,968	+240
23	82	34	W-WSCCE238234	2,028	+240
23	46	40	W-WSCCE234640	1,669	+200
23	52	40	W-WSCCE235240	1,730	+240
23	58	40	W-WSCCE235840	1,789	+240
23	64	40	W-WSCCE236440	1,848	+240
23	70	40	W-WSCCE237040	1,738	+240
23	76	40	W-WSCCE237640	1,968	+240
23	82	40	W-WSCCE238240	2,028	+240
23	52	46	W-WSCCE235246	1,760	+240
23	58	46	W-WSCCE235846	1,588	+240
23	64	46	W-WSCCE236446	1,912	+240
23	70	46	W-WSCCE237046	1,768	+240
23	76	46	W-WSCCE237646	1,695	+240
23	82	46	W-WSCCE238246	1,909	+240

HEIGHT ADJUSTABLE OFFSET SIZES – RIGHT HAND

D ¹	W ¹	W ²	Model Number	List	Grade C Laminate
23	34	40	W-WSCCE233440	1,610	+200
23	34	46	W-WSCCE233446	1,669	+200
23	34	52	W-WSCCE233452	1,730	+240
23	34	58	W-WSCCE233458	1,789	+240
23	34	64	W-WSCCE233464	1,848	+240
23	34	70	W-WSCCE233470	1,733	+240
23	34	76	W-WSCCE233476	1,968	+240
23	34	82	W-WSCCE233482	2,028	+240
23	40	46	W-WSCCE234046	1,669	+200
23	40	52	W-WSCCE234052	1,730	+240
23	40	58	W-WSCCE234058	1,694	+240
23	40	64	W-WSCCE234064	1,848	+240
23	40	70	W-WSCCE234070	1,738	+240
23	40	76	W-WSCCE234076	1,968	+240
23	40	82	W-WSCCE234082	2,028	+240
23	46	52	W-WSCCE234652	1,760	+240
23	46	58	W-WSCCE234658	1,588	+240
23	46	64	W-WSCCE234664	1,677	+240
23	46	70	W-WSCCE234670	1,768	+240
23	46	76	W-WSCCE234676	1,998	+240
23	46	82	W-WSCCE234682	1,909	+240

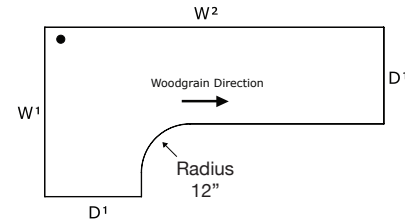
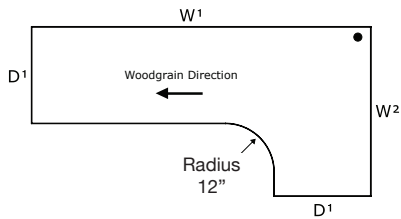

Specify

- Laminate Selection
- Color Selection for 2mm Edge
- Additional Grommet Locations (+38)
- Grommet Cover Color (if applicable)

Notes

- Worksurface support hardware is specified separately.
- Grommet holes with covers are specified as options.
- Height adjustable worksurface support base is specified separately.

Extended Curvilinear Corner Worksurfaces

HEIGHT ADJUSTABLE OFFSET SIZES – LEFT HAND

D ¹	W ¹	W ²	Model Number	List	Grade C Laminate
29	46	40	W-WSCCE294640	1,700	+200
29	52	40	W-WSCCE295240	1,760	+240
29	58	40	W-WSCCE295840	1,818	+240
29	64	40	W-WSCCE296440	1,879	+240
29	70	40	W-WSCCE297040	1,938	+240
29	76	40	W-WSCCE297640	1,998	+240
29	82	40	W-WSCCE298240	2,056	+240
29	52	46	W-WSCCE295246	1,818	+240
29	58	46	W-WSCCE295846	1,879	+240
29	64	46	W-WSCCE296446	1,938	+240
29	70	46	W-WSCCE297046	1,998	+240
29	76	46	W-WSCCE297646	2,056	+240
29	82	46	W-WSCCE298246	2,117	+240

HEIGHT ADJUSTABLE OFFSET SIZES – RIGHT HAND

D ¹	W ¹	W ²	Model Number	List	Grade C Laminate
29	40	46	W-WSCCE294046	1,700	+200
29	40	52	W-WSCCE294052	1,760	+240
29	40	58	W-WSCCE294058	1,818	+240
29	40	64	W-WSCCE294064	1,879	+240
29	40	70	W-WSCCE294070	1,938	+240
29	40	76	W-WSCCE294076	1,998	+240
29	40	82	W-WSCCE294082	2,056	+240
29	46	52	W-WSCCE294652	1,818	+240
29	46	58	W-WSCCE294658	1,879	+240
29	46	64	W-WSCCE294664	1,938	+240
29	46	70	W-WSCCE294670	1,998	+240
29	46	76	W-WSCCE294676	2,056	+240
29	46	82	W-WSCCE294682	2,117	+240

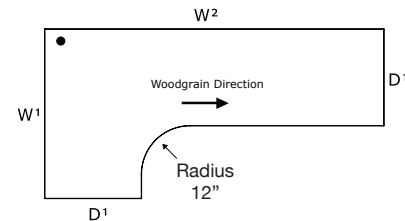
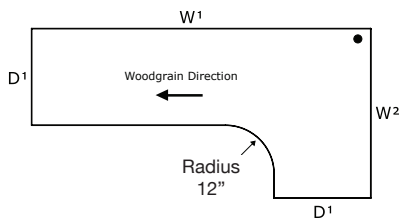

Specify

Notes

- | | |
|---|---|
| <ul style="list-style-type: none"> • Laminate Selection • Color Selection for 2mm Edge • Additional Grommet Locations (+38) • Grommet Cover Color (if applicable) | <ul style="list-style-type: none"> • Worksurface support hardware is specified separately. • Grommet holes with covers are specified as options. • Height adjustable worksurface support base is specified separately. |
|---|---|

Extended Curvilinear Corner Worksurfaces

DEPTH TRANSITION W/HEIGHT ADJUSTABLE OFFSET – LEFT HAND

D ¹	W ¹	W ²	D ²	Model Number	List	Grade C Laminate
23	46	40	29	W-WSCCE23464029	1,664	+200
23	52	40	29	W-WSCCE23524029	1,676	+240
23	58	40	29	W-WSCCE23584029	1,689	+240
23	64	40	29	W-WSCCE23644029	1,700	+240
23	70	40	29	W-WSCCE23704029	1,712	+240
23	76	40	29	W-WSCCE23764029	1,724	+240
23	82	40	29	W-WSCCE23824029	1,736	+240
23	52	46	29	W-WSCCE23524629	1,831	+240
23	58	46	29	W-WSCCE23584629	1,843	+240
23	64	46	29	W-WSCCE23644629	1,856	+240
23	70	46	29	W-WSCCE23704629	1,867	+240
23	76	46	29	W-WSCCE23764629	1,879	+240
23	82	46	29	W-WSCCE23824629	1,891	+240
29	46	40	23	W-WSCCE29464023	1,664	+200
29	52	40	23	W-WSCCE29524023	1,676	+240
29	58	40	23	W-WSCCE29584023	1,689	+240
29	64	40	23	W-WSCCE29644023	1,700	+240
29	70	40	23	W-WSCCE29704023	1,712	+240
29	76	40	23	W-WSCCE29764023	1,724	+240
29	82	40	23	W-WSCCE29824023	1,736	+240
29	52	46	23	W-WSCCE29524623	1,831	+240
29	58	46	23	W-WSCCE29584623	1,843	+240
29	64	46	23	W-WSCCE29644623	1,856	+240
29	70	46	23	W-WSCCE29704623	1,867	+240
29	76	46	23	W-WSCCE29764623	1,879	+240
29	82	46	23	W-WSCCE29824623	1,942	+240

DEPTH TRANSITION W/HEIGHT ADJUSTABLE OFFSET – RIGHT HAND

D ¹	W ¹	W ²	D ²	Model Number	List	Grade C Laminate
23	40	46	29	W-WSCCE23404629	1,664	+200
23	40	52	29	W-WSCCE23405229	1,676	+240
23	40	58	29	W-WSCCE23405829	1,689	+240
23	40	64	29	W-WSCCE23406429	1,700	+240
23	40	70	29	W-WSCCE23407029	1,712	+240
23	40	76	29	W-WSCCE23407629	1,724	+240
23	40	82	29	W-WSCCE23408229	1,736	+240
23	46	52	29	W-WSCCE23465229	1,831	+240
23	46	58	29	W-WSCCE23465829	1,843	+240
23	46	64	29	W-WSCCE23466429	1,856	+240
23	46	70	29	W-WSCCE23467029	1,867	+240
23	46	76	29	W-WSCCE23467629	1,879	+240
23	46	82	29	W-WSCCE23468229	1,891	+240
29	40	46	23	W-WSCCE29404623	1,664	+200
29	40	52	23	W-WSCCE29405223	1,676	+240
29	40	58	23	W-WSCCE29405823	1,689	+240
29	40	64	23	W-WSCCE29406423	1,700	+240
29	40	70	23	W-WSCCE29407023	1,712	+240
29	40	76	23	W-WSCCE29407623	1,724	+240
29	40	82	23	W-WSCCE29408223	1,736	+240
29	46	52	23	W-WSCCE29465223	1,831	+240
29	46	58	23	W-WSCCE29465823	1,843	+240
29	46	64	23	W-WSCCE29466423	1,856	+240
29	46	70	23	W-WSCCE29467023	1,867	+240
29	46	76	23	W-WSCCE29467623	1,879	+240
29	46	82	23	W-WSCCE29468223	1,891	+240

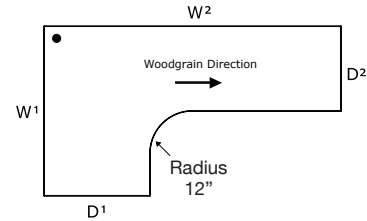
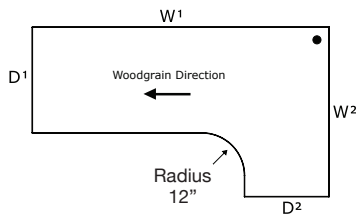

Specify

- Laminate Selection
- Color Selection for 2mm Edge
- Additional Grommet Locations (+38)
- Grommet Cover Color (if applicable)

Notes

- Worksurface support hardware is specified separately.
- Grommet holes with covers are specified as options.
- Height adjustable worksurface support base is specified separately.

D-Tops

D TOPS				
D'	W'	Model Number	List	Grade C Laminate
24	48	W-WSD2448	904	+110
24	54	W-WSD2454	948	+200
24	60	W-WSD2460	992	+200
24	66	W-WSD2466	1,037	+200
24	72	W-WSD2472	1,116	+200
24	78	W-WSD2478	1,204	+200
24	84	W-WSD2484	1,291	+200
30	48	W-WSD3048	979	+200
30	54	W-WSD3054	1,014	+240
30	60	W-WSD3060	1,020	+240
30	66	W-WSD3066	1,116	+240
30	72	W-WSD3072	1,213	+240
30	78	W-WSD3078	1,303	+240
30	84	W-WSD3084	1,393	+240
36	48	W-WSD3648	1,097	+200
36	54	W-WSD3654	1,313	+240
36	60	W-WSD3660	1,318	+240
36	66	W-WSD3666	1,413	+240
36	72	W-WSD3672	1,510	+240
36	78	W-WSD3678	1,601	+240
36	84	W-WSD3684	1,691	+240

D TOPS				
D'	W'	Model Number	List	Grade C Laminate
42	48	W-WSD4248	1,217	+200
42	54	W-WSD4254	1,610	+240
42	60	W-WSD4260	1,617	+240
42	66	W-WSD4266	1,710	+240
42	72	W-WSD4272	1,808	+240
42	78	W-WSD4278	1,899	+240
42	84	W-WSD4284	1,988	+240
48	48	W-WSD4848	1,335	+200
48	54	W-WSD4854	1,908	+240
48	60	W-WSD4860	1,914	+240
48	66	W-WSD4866	2,009	+240
48	72	W-WSD4872	2,107	+240
48	78	W-WSD4878	2,196	+240
48	84	W-WSD4884	2,286	+240

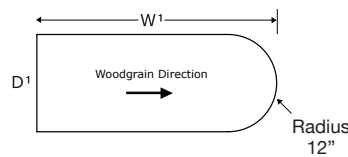

Specify

Notes

- Laminate Selection
- Color Selection for 2mm Edge
- Additional Grommet Locations (+38)
- Grommet Cover Color (if applicable)

- Worksurface support hardware is specified separately.
- Grommet holes with covers are specified as options.

P-TOPS						
Hand	D ¹	D ²	W ¹	Model Number	List	Grade C Laminate
Left	30	36	60	W-WSPL3060	1,298	+67
Left	30	36	66	W-WSPL3066	1,395	+72
Left	30	36	72	W-WSPL3072	1,488	+78
Left	30	36	84	W-WSPL3084	1,742	+91
Right	30	36	60	W-WSPR3060	1,298	+67
Right	30	36	66	W-WSPR3066	1,395	+72
Right	30	36	72	W-WSPR3072	1,488	+78
Right	30	36	84	W-WSPR3084	1,742	+91

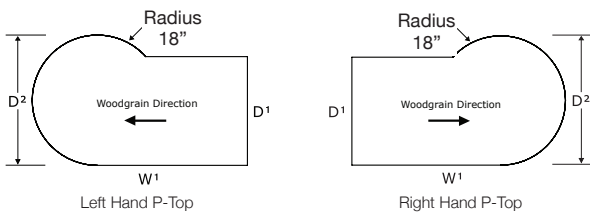

Specify

- Laminate Selection
- Color Selection for 2mm Edge
- Additional Grommet Locations (+38)
- Grommet Cover Color (if applicable)

Notes

- Worksurface support hardware is specified separately.
- Grommet holes with covers are specified as options.

System Specific Spanner Half Moons

⚠ The following worksurface is designed for use with Divi systems only:

DIVI SPANNER HALF MOONS

D¹	D²	W¹	Model Number	List	Grade C Laminate
24	25 1/8	50 1/8	W-WSHM2450DV	929	+48
30	31 1/8	61 3/4	W-WSHM3062DV	993	+51

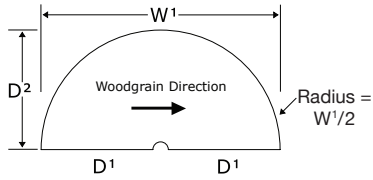

Specify **Notes**

- | | |
|--|---|
| <ul style="list-style-type: none"> • Laminate Selection • Color Selection for 2mm Edge | <ul style="list-style-type: none"> • For use with Divi. • Worksurface support hardware is specified separately. |
|--|---|

Rounds and 120° Corners

ROUNDS

W'	Model Number	List	Grade C Laminate	Swing Hole
30	C-TBLR30	736	+39	+38
36	C-TBLR36	1,054	+56	+38
42	C-TBLR42	1,258	+67	+38
48	C-TBLR48	1,316	+70	+38

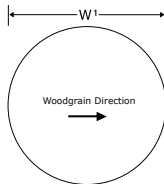

Specify

- Laminate Selection
- Color Selection for 2mm Edge

Notes

- Worksurface support hardware is specified separately.

120° C, 90° L, 90° R CORNER

D'	W'	Model Number	List	Grade C Laminate
24	36	W-WSYCC2436	913	+47
24	42	W-WSYCC2442	1,103	+58
24	48	W-WSYCC2448	1,218	+64
30	42	W-WSYCC3042	1,215	+63
30	48	W-WSYCC3048	1,389	+72

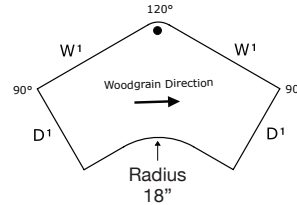

Specify

- Laminate Selection
- Color Selection for 2mm Edge
- Additional Grommet Locations (+38)
- Grommet Cover Color

Notes

- Worksurface support hardware is specified separately.
- Rear corner grommet hole with cover is included.
- Additional grommet holes with covers are specified as options.

Shelf Surfaces and Rectangular / Radius Transactions

SHELF SURFACE				
D'	W'	Model Number	List	Grade C Laminate
12	24	W-CT1224	318	+17
12	30	W-CT1230	341	+18
12	36	W-CT1236	367	+19
12	42	W-CT1242	379	+20
12	48	W-CT1248	387	+21
12	54	W-CT1254	450	+24
12	60	W-CT1260	456	+24
12	66	W-CT1266	479	+27
12	72	W-CT1272	511	+27
12	78	W-CT1278	521	+28
12	84	W-CT1284	527	+28
12	90	W-CT1290	539	+29
12	96	W-CT1296	547	+29

RECTANGULAR TRANSACTION				
D'	W'	Model Number	List	Grade C Laminate
15	24	W-CT1524	333	+17
15	30	W-CT1530	362	+18
15	36	W-CT1536	383	+19
15	42	W-CT1542	396	+20
15	48	W-CT1548	411	+21
15	54	W-CT1554	471	+24
15	60	W-CT1560	476	+24
15	66	W-CT1566	535	+27
15	72	W-CT1572	535	+27
15	84	W-CT1584	556	+28
15	96	W-CT1596	573	+29

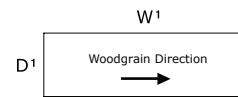
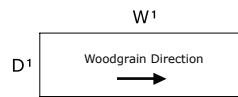
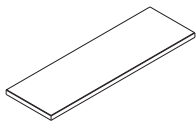

RADIUS TRANSACTION				
D'	W'	Model Number	List	Grade C Laminate
15	31.5	W-CT1524R	436	+17
15	37.5	W-CT1530R	459	+18
15	43.5	W-CT1536R	482	+19
15	49.5	W-CT1542R	504	+20
15	55.5	W-CT1548R	513	+21
15	61.5	W-CT1554R	569	+24
15	67.5	W-CT1560R	579	+24
15	73.5	W-CT1566R	636	+27
15	79.5	W-CT1572R	636	+27
15	91.5	W-CT1584R	656	+28

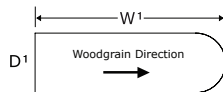

Specify

Notes

- Laminate Selection
- Color Selection for 2mm Edge

- Worksurface support hardware is specified separately.

GROMMET HOLE COVERS

Diameter	Model Number	List
3	W-GROMMET	46

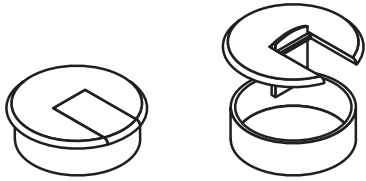

Specify	Notes
----------------	--------------

- | | |
|--|--|
| <ul style="list-style-type: none"> • Color Selection - White, Black or Grey Value 1 | <ul style="list-style-type: none"> • Grommet Hole Covers for cord management may be specified when ordering worksurfaces. • Grommet covers are included when worksurfaces are ordered with grommets. Order separately only if extra covers are required or if retrofitting grommets in the field. • Grommet holes required are 2 3/4" outside diameter with a 2 5/8" inside diameter (inside sleeve). • Available in White, Black or Grey Value 1. |
|--|--|



National Showrooms:

Leominster

AIS Headquarters
25 Tucker Drive
Leominster, MA 01453

Chicago

The Merchandise Mart
Suite 391
Chicago, Illinois 60654

New York

AIS New York
257 Park Avenue South
New York, New York 10010

Washington, D.C.

AIS Washington, D.C.
1501 M St, NW, STE 230
Washington, D.C. 20005

GSA Sales

GSA Contract GS-29F-0006K
FSC Group 71,
Part 1 Office Furniture

For additional information on AIS:

Dealer Showrooms, Representative
Directory, Project Case Studies, Online
Catalog & Product Showcase
Visit: www.ais-inc.com