

# Calibrate Standard Run-Offs Installation Instructions

Date	Page No.	Description of change	Name
8/30/2022	1-15	Released	S. Powers

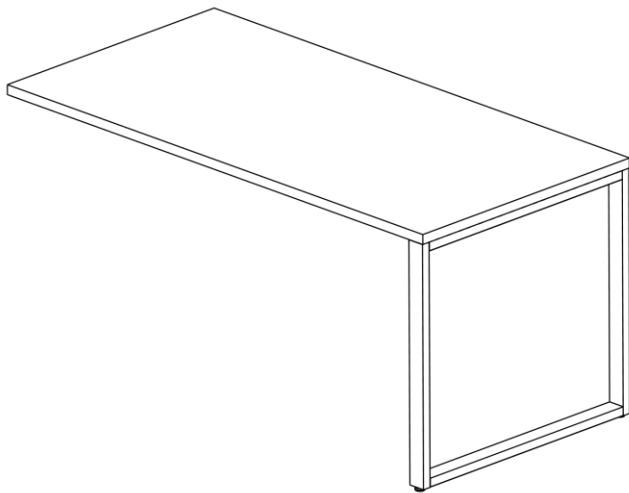

Rectangular Run-off  
with O-Leg  
See pages 3-6

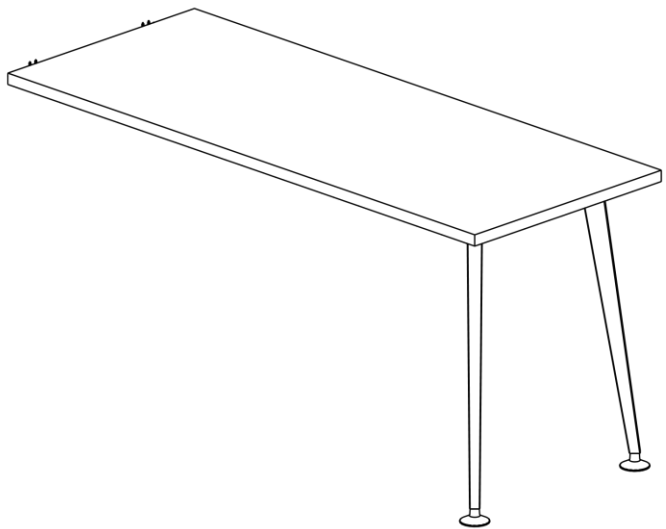

Run-off with Tapered Leg  
See pages 7-11

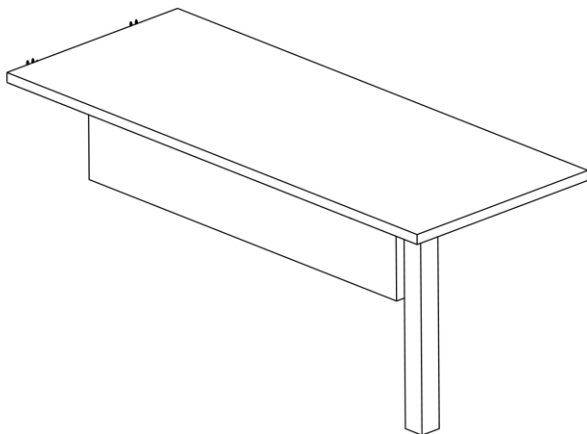

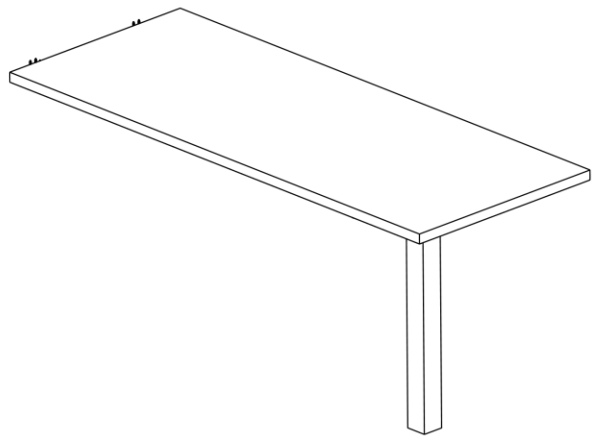

Rectangular Run-off  
with Post-Leg with Modesty  
See pages 12-15



Rectangular Run-off  
with Post-Leg without Modesty  
See pages 12-15

# Calibrate Standard Run-Offs Installation Instructions

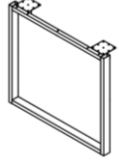
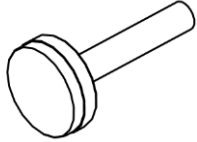
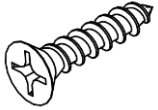
## Rectangular Run-Off with O-Leg

Item	Replacement Part number	Circle Sheet Part Number	Description	Image
P1	WFS-OL27xxFS-2 xx = 18, 24, 30 or 36	RC-SOL27xxFS-2 xx = 18, 24, 30 or 36	Freestanding O-Leg	
P2	WFS-GL51618	RWFS-GL51618-I	5/16-18 Glide	
P3	RH-QS0978	RH-QS0978	Flat Head Screw #9 x 7/8"	
P4	T-UCKxx xx= 36-72 (increments of 6")	RWPS-HSxx xx= 36-72 (increments of 6")	U-Channel	
P5	WPS-FP	RWPS-FP	Flat Plate	

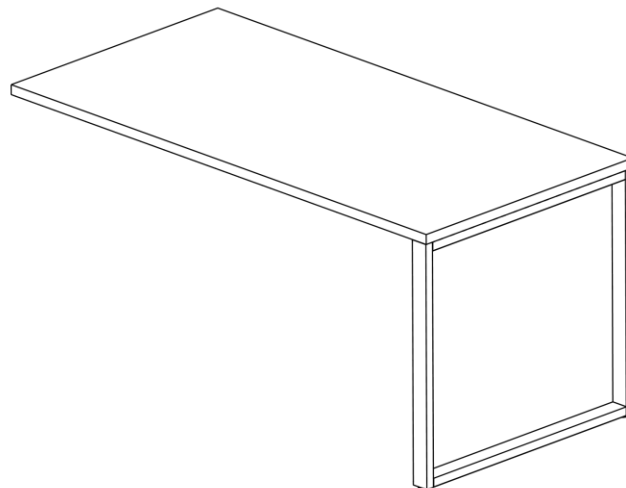

# Calibrate Standard Run-Offs Installation Instructions

## Rectangular Run-Off with O-Leg

**Step 1:** Install glides into the bottom of each O-Leg.

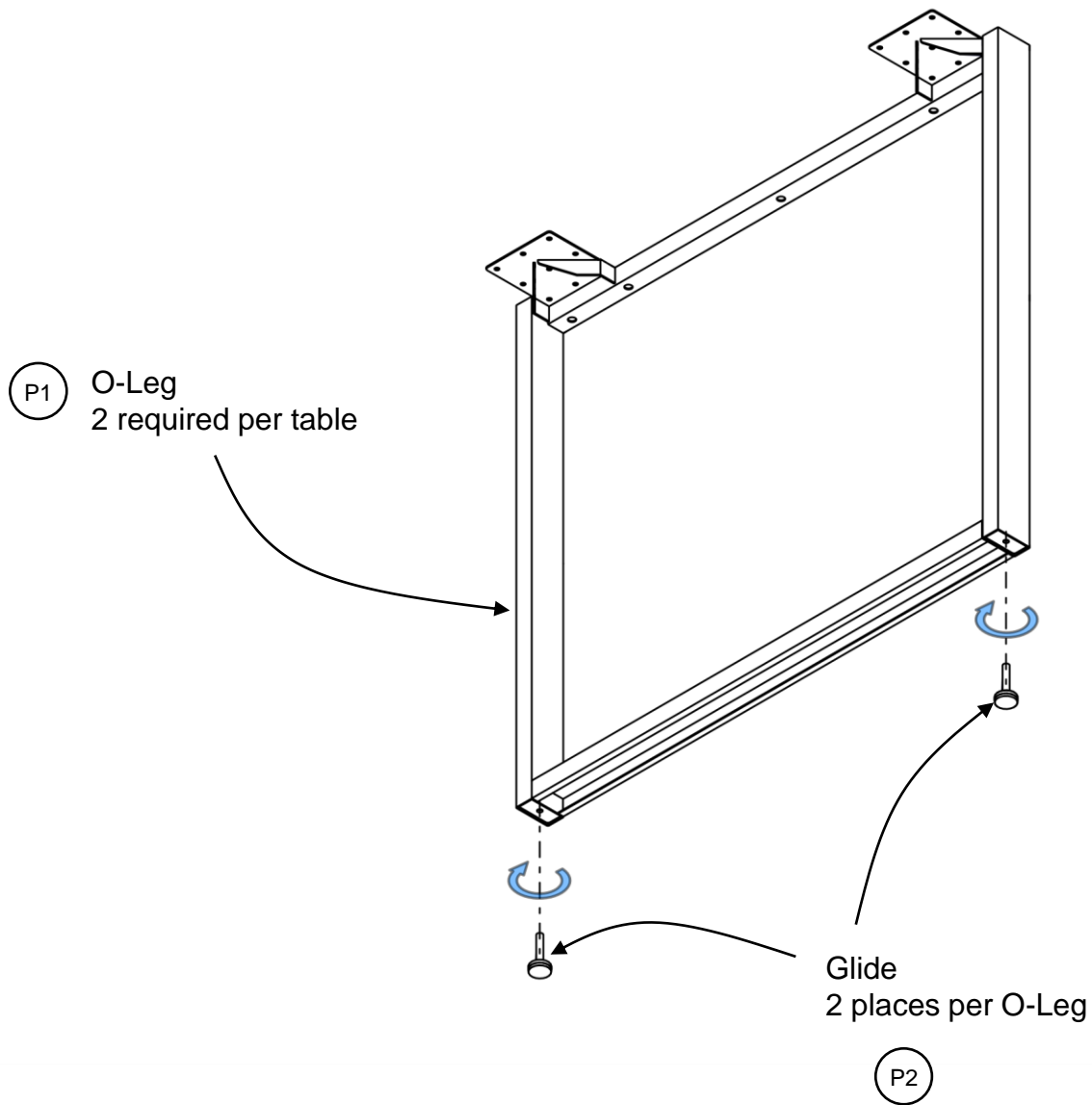

# Calibrate Standard Run-Offs Installation Instructions

## Rectangular Run-Off with O-Leg

**Step 2:** Align O-Legs to the worksurface and secure using #9 x 7/8" worksurface screws.

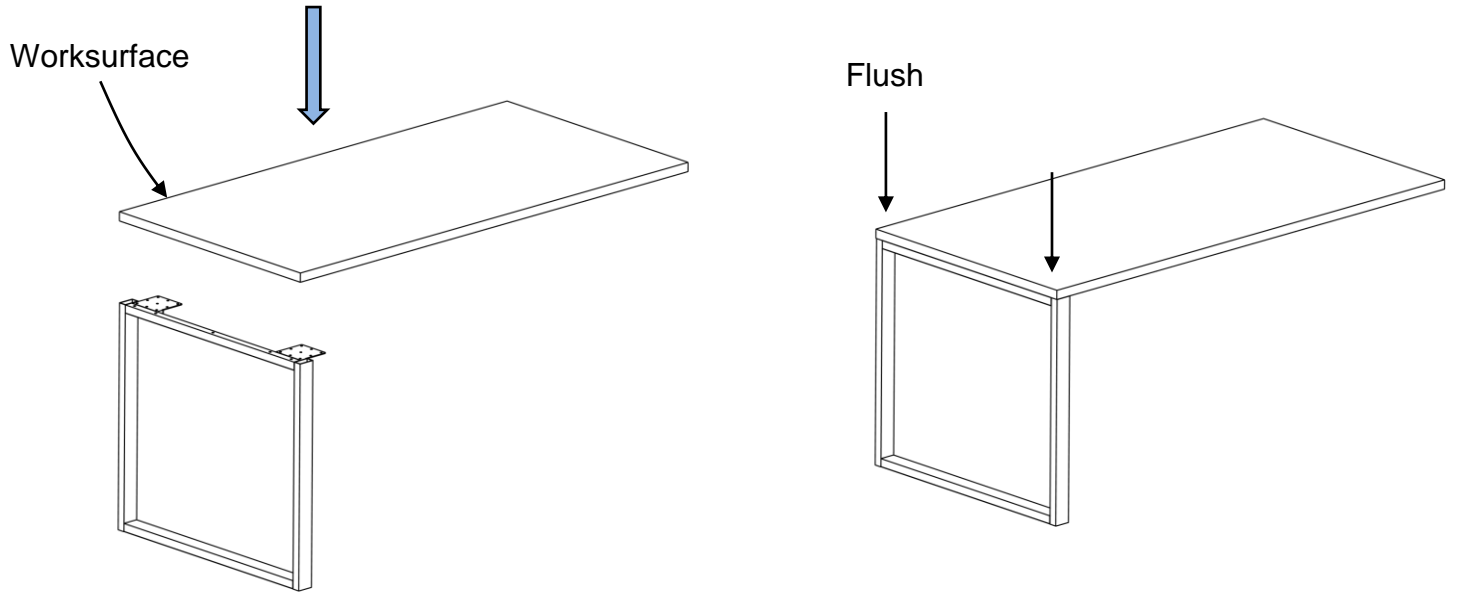

P3

#9 x 7/8" long  
Flat Head Wood Screw  
#2 Philips drive  
5 places per O-leg

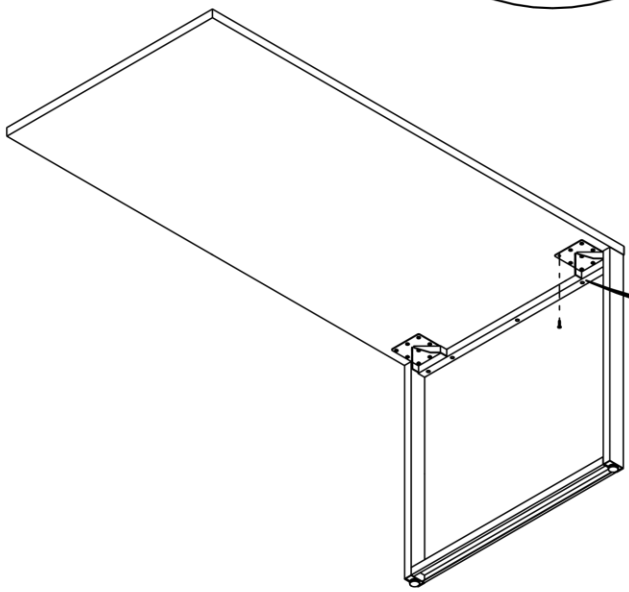
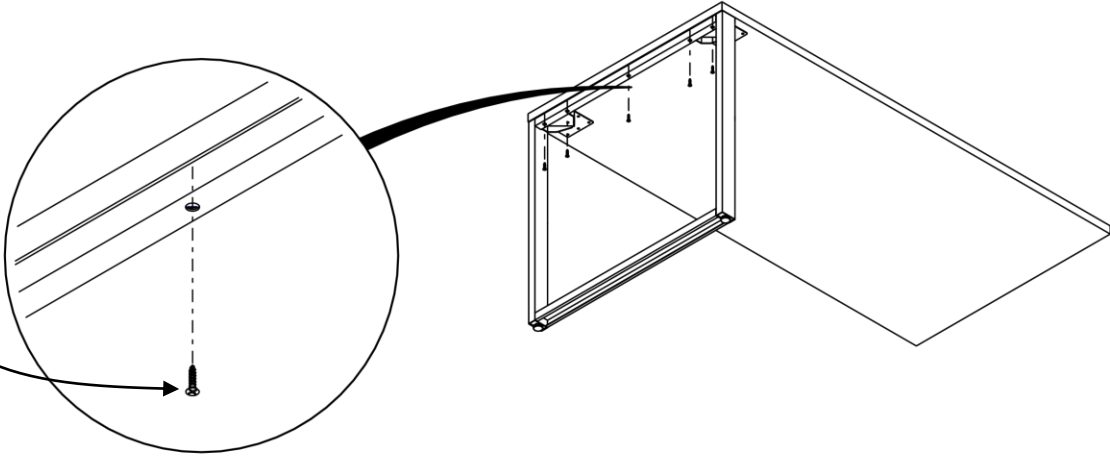

P3

#9 x 7/8" long  
Flat Head Wood Screw  
#2 Philips drive  
18 places per O-Leg

# Calibrate Standard Run-Offs Installation Instructions

## Rectangular Run-Off with O-Leg

**Step 3:** Install U-Channels to the worksurface using #9 x 7/8" worksurface screws.

U-Channel  
 24D X 36W = Qty 0  
 24D X 42W – 84W = Qty 1  
 30D X 36W = Qty 0  
 30D X 42W – 72W = Qty 1  
 36D X 72W = Qty 1

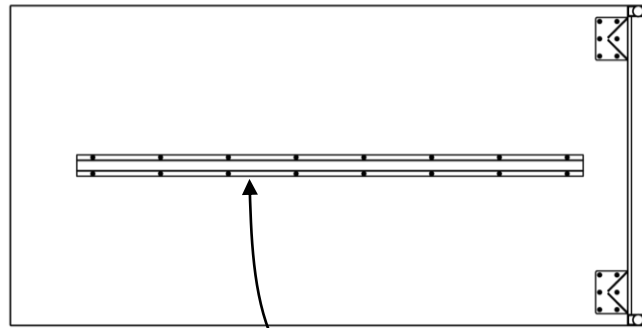

Center U-Channel  
 on Worksurface

P4

U-Channel  
 30D X 78W – 84W = Qty 2  
 36D X 78W = Qty 2

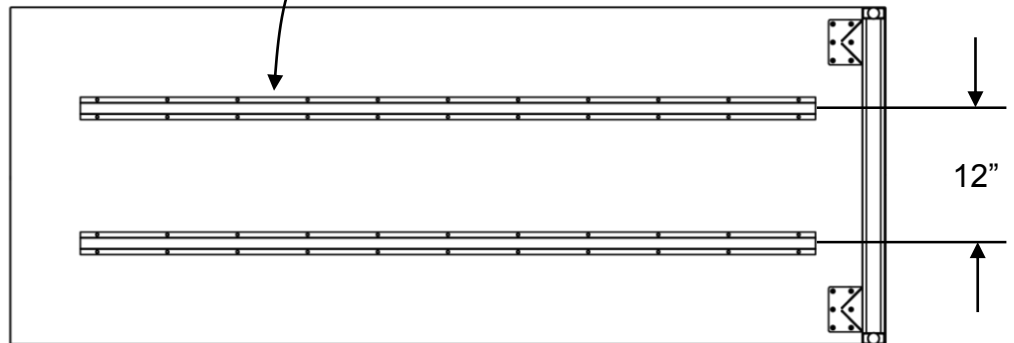

12"

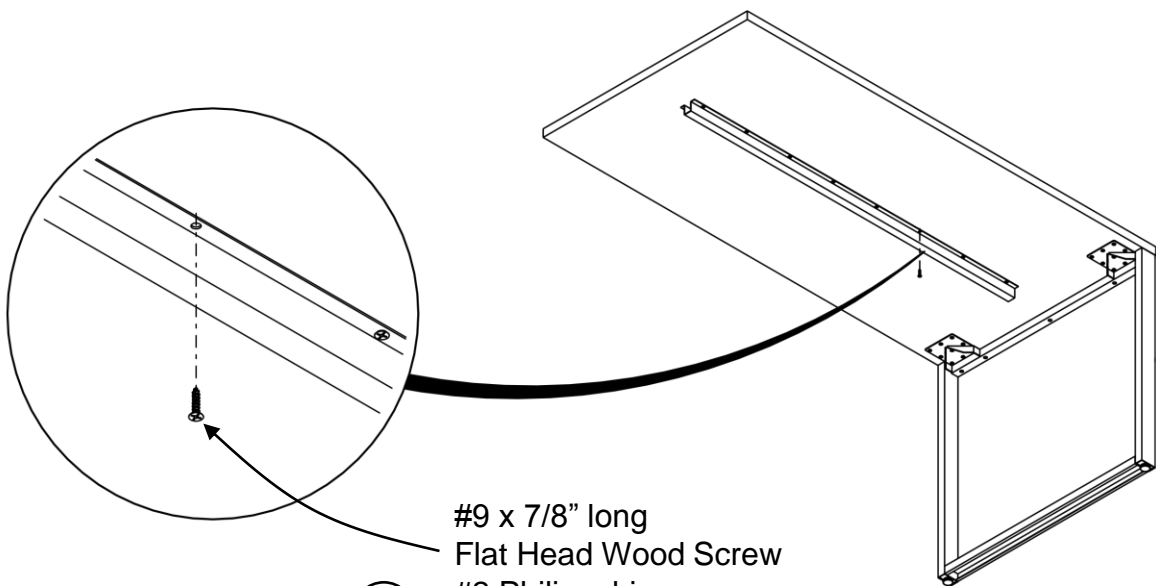

#9 x 7/8" long  
 Flat Head Wood Screw  
 #2 Philips drive  
 Install screws in all hole  
 locations

P3

# Calibrate Standard Run-Offs Installation Instructions





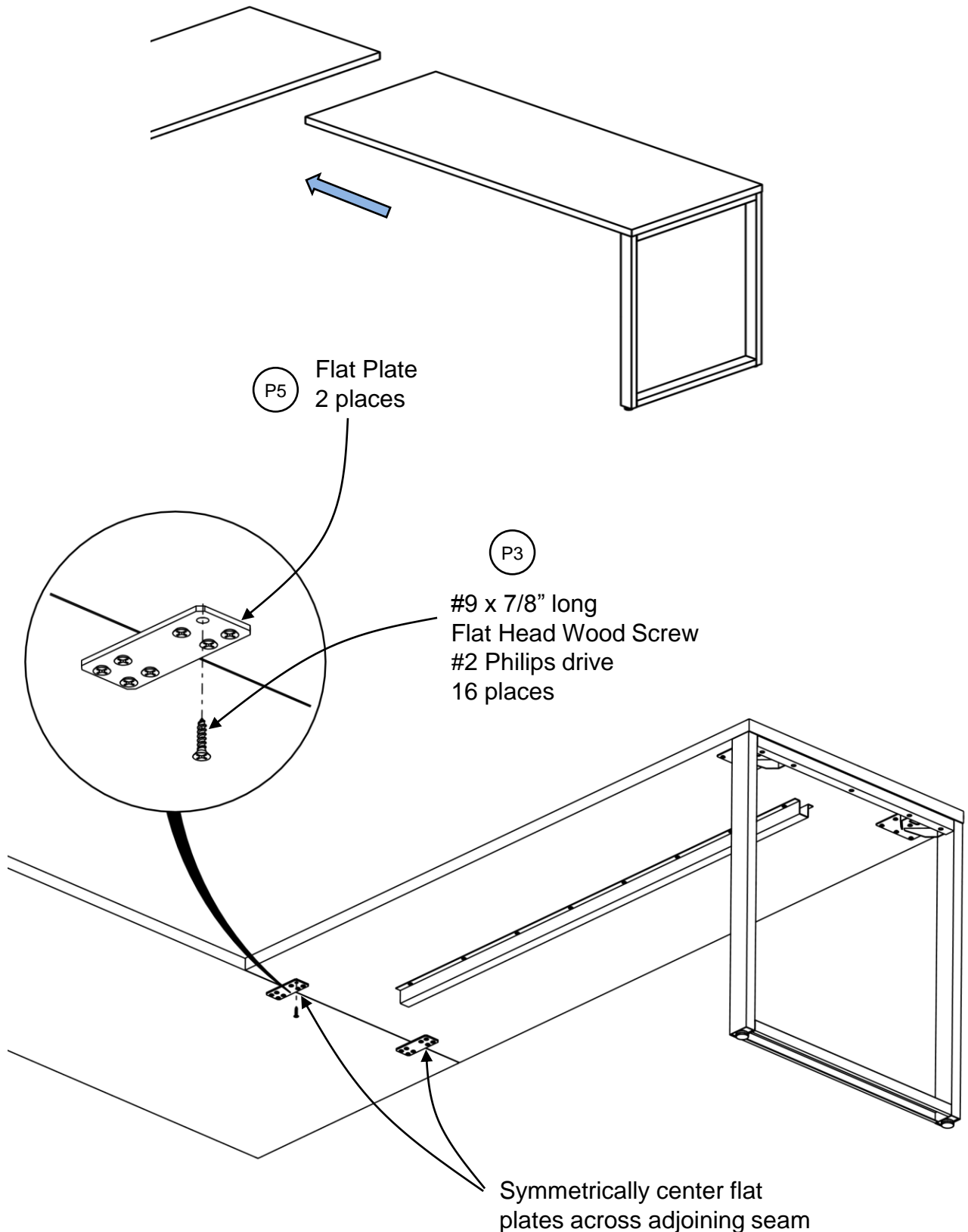

## Rectangular Run-Off with O-Leg

**Step 4:** Secure to adjacent supportive surface using flat plates and screws.

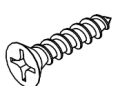

# Calibrate Standard Run-Offs Installation Instructions

## Run-Off with Tapered Leg

Item	Replacement Part number	Circle Sheet Part Number	Description	Image
P1	T-LEG26	RC-LEG26	Tapered Leg	
P2	T-LEGTP	RC-LEGTP	Top Plate	
P3	RH-APSHBF38161	RH-APSHBF38161	3/8-16 x 1" Flat Head Screw	
P4	WFS-UTG	RWFS-UTG-I	Glide	
P5	RH-QS0978	RH-QS0978	Flat Head Screw #9 x 7/8"	
P6	T-UCKxx xx= 36-72 (increments of 6")	RWPS-HSxx xx= 36-72 (increments of 6")	U-Channel	
P7	WPS-FP	RWPS-FP	Flat Plate	

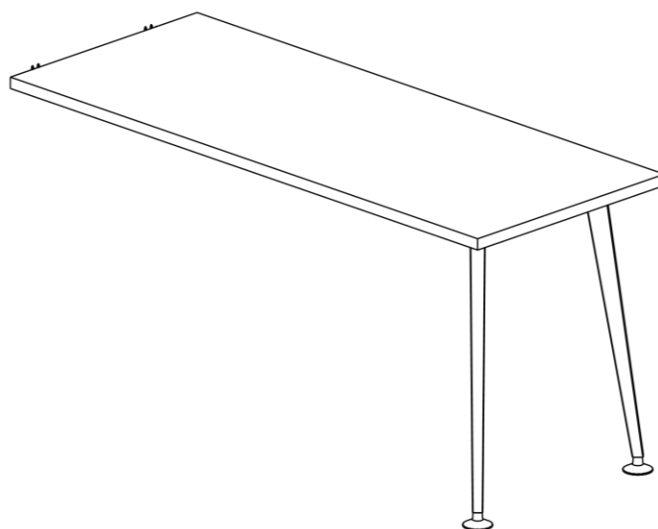

# Calibrate Standard Run-Offs Installation Instructions

## Run-Off with Tapered Leg

**Step 1:** Assemble 2 tapered legs as shown.

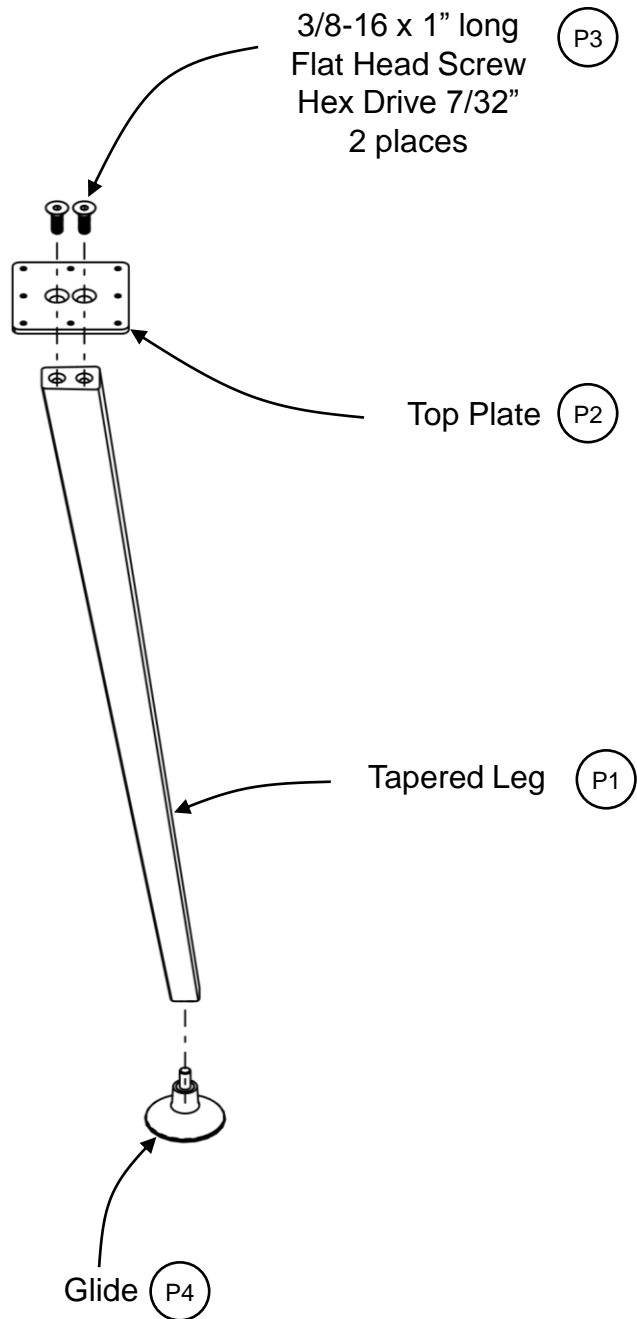

# Calibrate Standard Run-Offs Installation Instructions

## Run-Off with Tapered Leg

**Step 2:** Position tapered legs as shown and secure to the run-off surface using #9 x 7/8" screws.

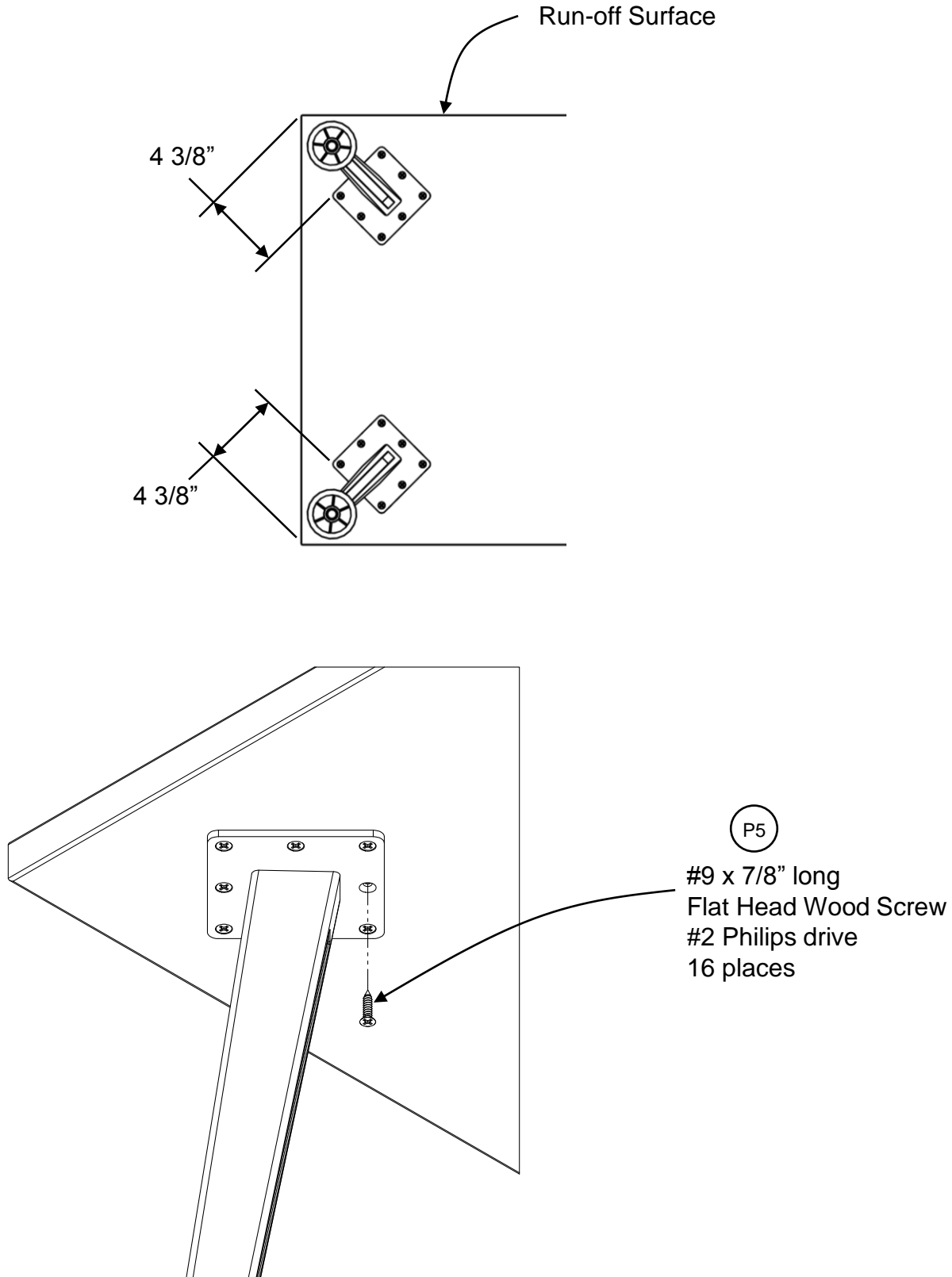

# Calibrate Standard Run-Offs Installation Instructions

## Run-Off with Tapered Leg

**Step 3:** Install U-Channels to the worksurface using #9 x 7/8" worksurface screws.

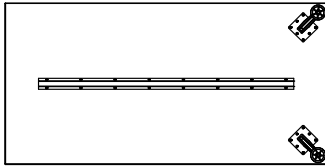

Depth	Width	U-channel in.
30"	60"	48"
30"	66"	54"
30"	72"	60"

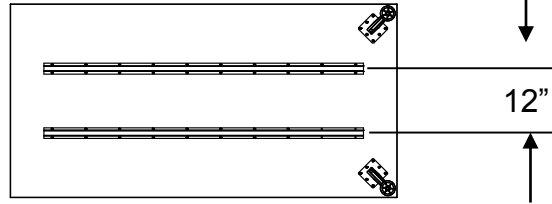

Depth	Width	U-channel in.
30"	78"	66"
36"	72"	60"
36"	78"	66"

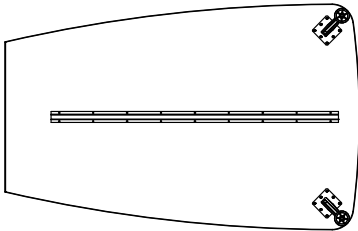

Depth	Width	U-channel in.
42"	66"	54"
42"	72"	60"
42"	78"	66"

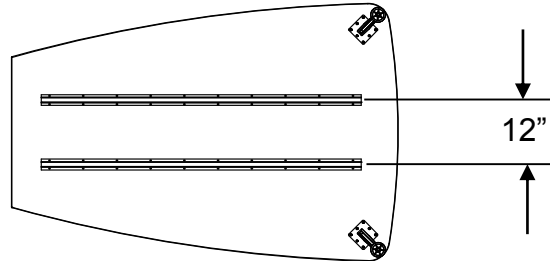

Depth	Width	U-channel in.
48"	66"	54"
48"	72"	60"
428"	78"	66"

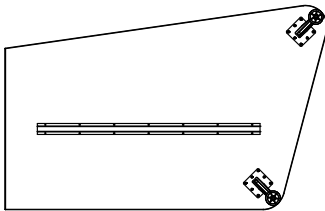

Depth	Width	U-channel in.
30"	60"	42"
30"	66"	48"
30"	72"	54"

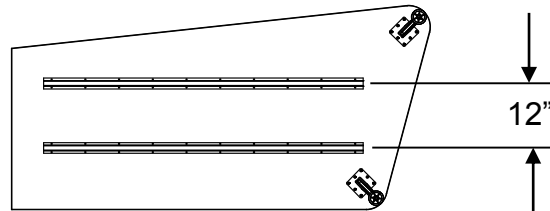

Depth	Width	U-channel in.
30"	78"	60"

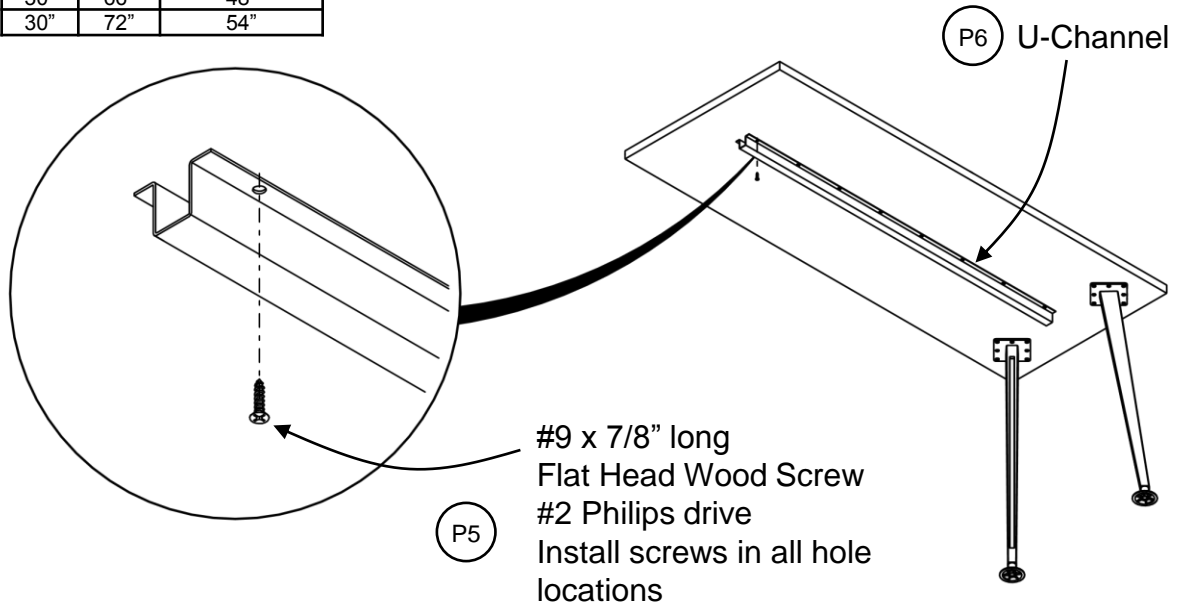

# Calibrate Standard Run-Offs Installation Instructions



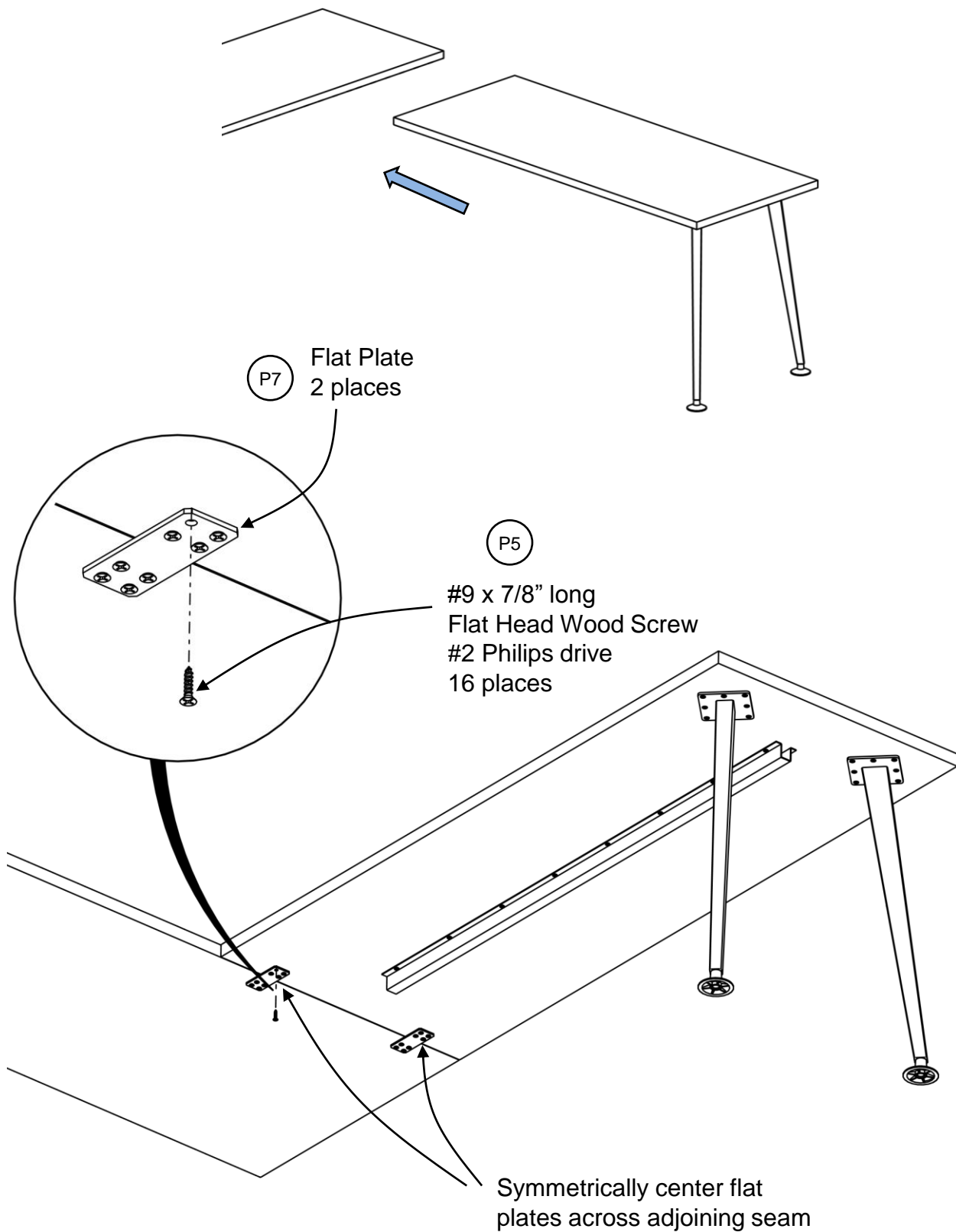

## Run-Off with Tapered Leg

**Step 4:** Secure to adjacent supportive surface using flat plates and screws.

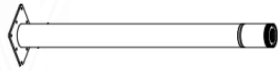
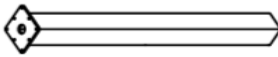
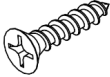

# Calibrate Standard Run-Offs Installation Instructions

## Rectangular Run-Off with Single Post Leg with or without Modesty

Item	Replacement Part number	Circle Sheet Part Number	Description	Image
P1	WFS-LEG	WFSLEG	Round Post Leg	
P2	WFS-PL252527	WFSPL252527	Square Post Leg	
P3	RH-QS0978	RH-QS0978	Flat Head Screw #9 x 7/8"	
P4	L-MPB	RL-MPB	L-Bracket	
P5	T-UCKxx xx= 36-72 (increments of 6")	RWPS-HSxx xx= 36-72 (increments of 6")	U-Channel	
P6	WPS-FP	RWPS-FP	Flat Plate	

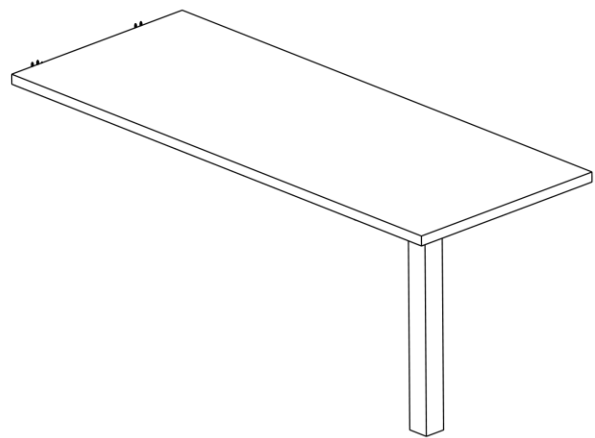
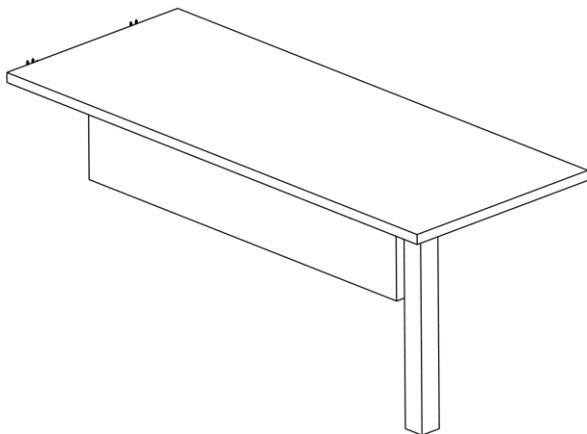

# Calibrate Standard Run-Offs Installation Instructions

## Rectangular Run-Off with Single Post Leg with or without Modesty

**Step 1:** Position post leg as shown and secure to the run-off surface using #9 x 7/8" screws.

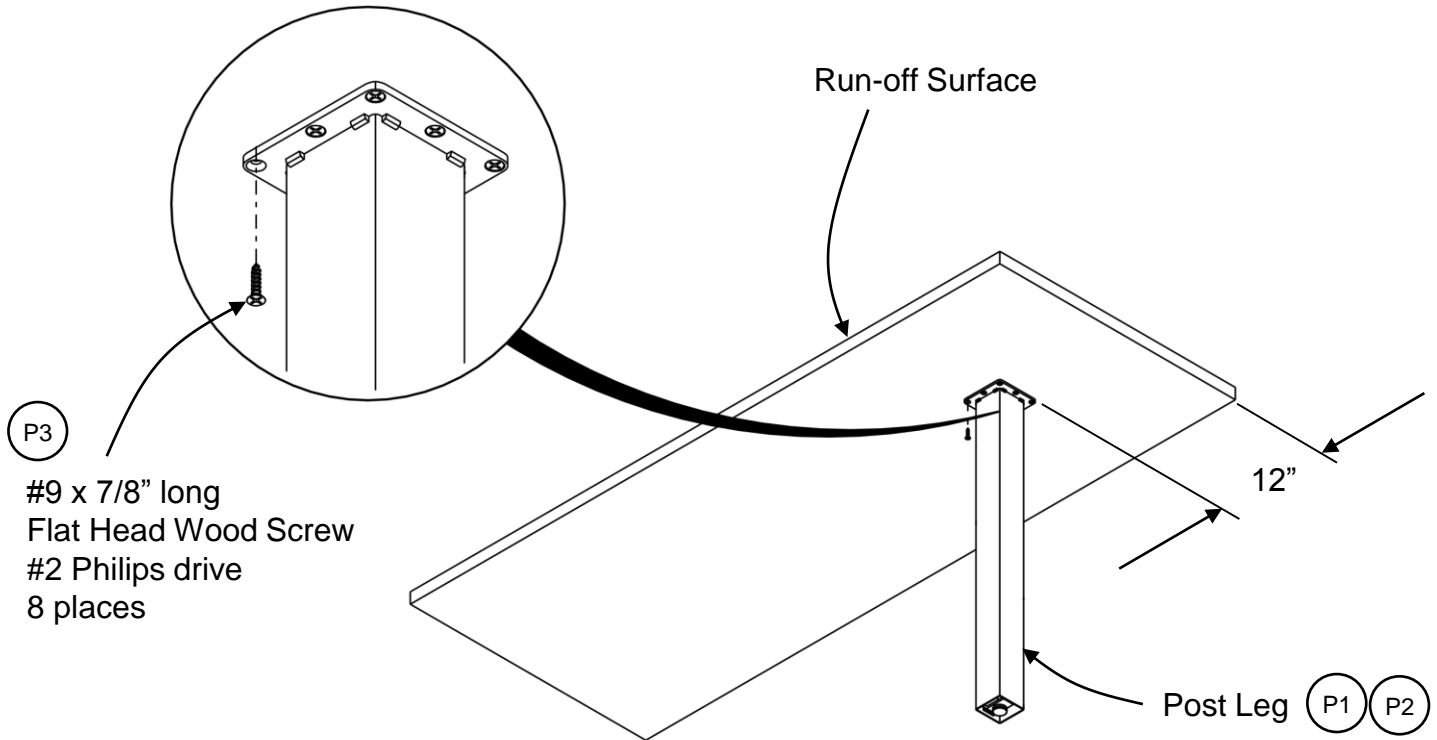

**Step 2 (for configurations with modesty only):** Install the modesty panel to the run-off surface using L-brackets and #9 x 7/8" screws.

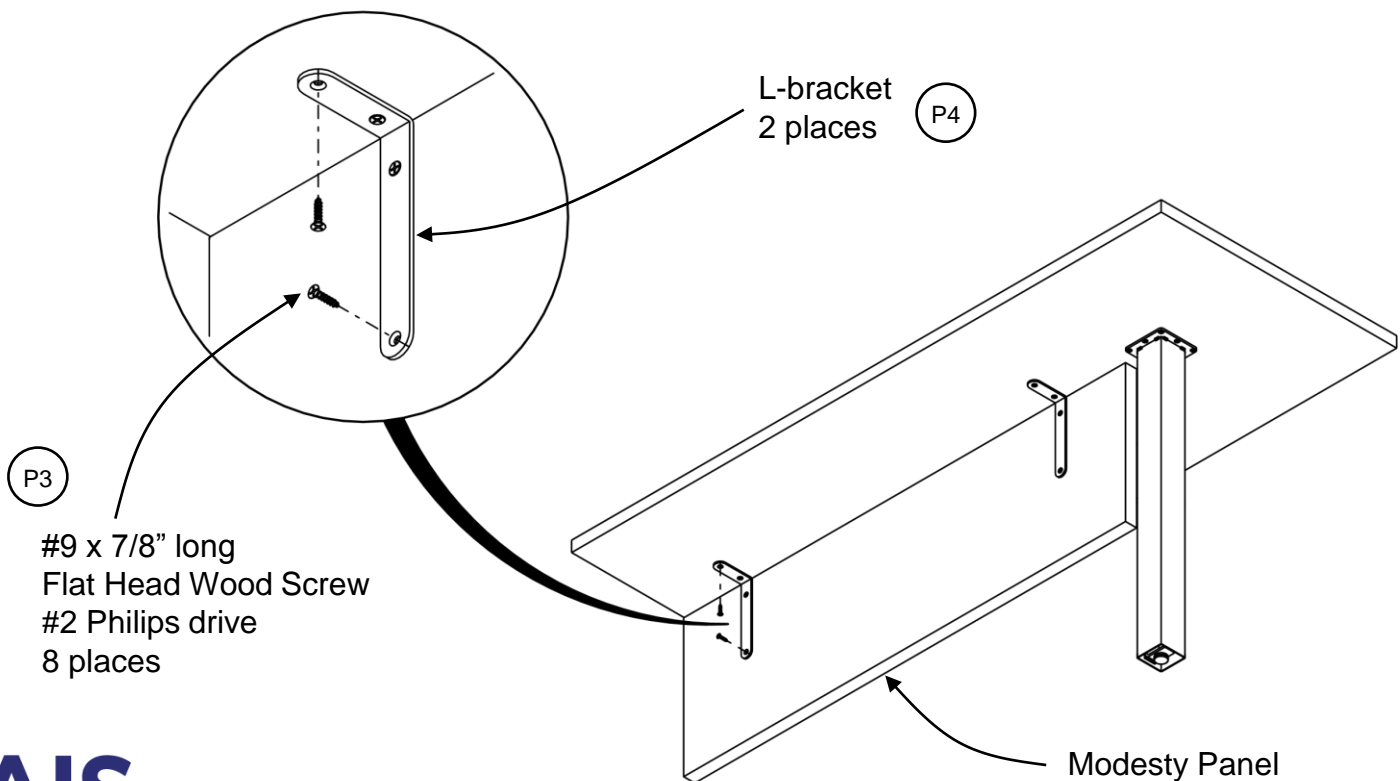

# Calibrate Standard Run-Offs Installation Instructions

## Rectangular Run-Off with Single Post Leg with or without Modesty

**Step 3:** Install U-Channels to the worksurface using #9 x 7/8" worksurface screws.

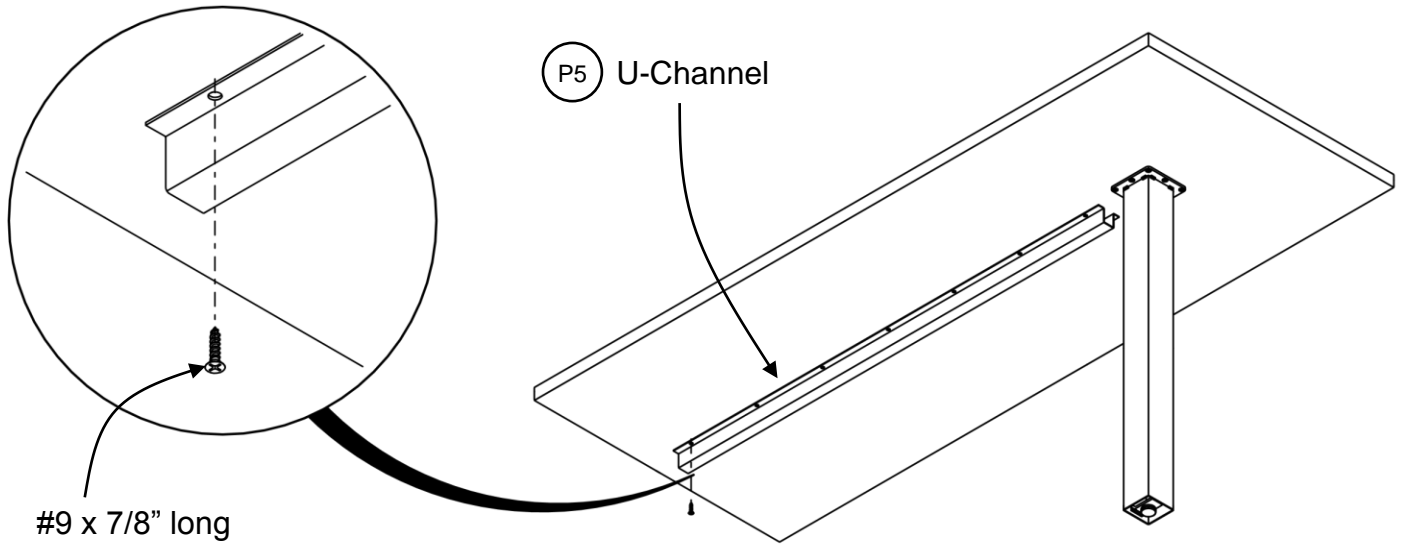

**#9 x 7/8" long  
Flat Head Wood Screw  
#2 Philips drive  
Install screws in all hole  
locations**

P3

Depth	Width	U-channel in.
24"	36"	n/a
24"	42"	n/a
24"	48"	30"
24"	54"	36"
24"	60"	42"
24"	66"	48"

Note:  
U-Channel not required for  
24D units with modesty

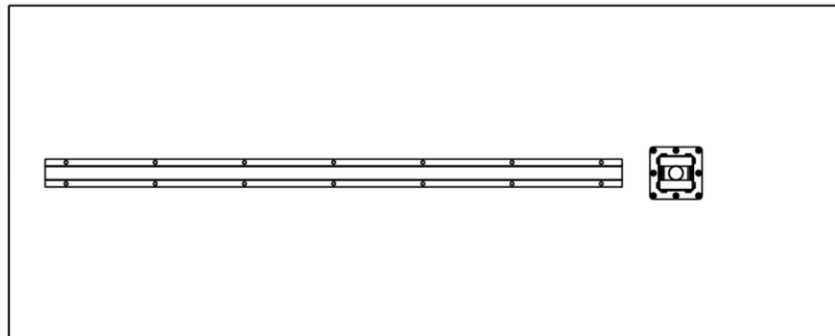

Depth	Width	U-channel in.
30"	48"	36"
30"	54"	42"
30"	60"	48"
30"	66"	54"
30"	72"	60"
36"	66"	54"
36"	72"	60"

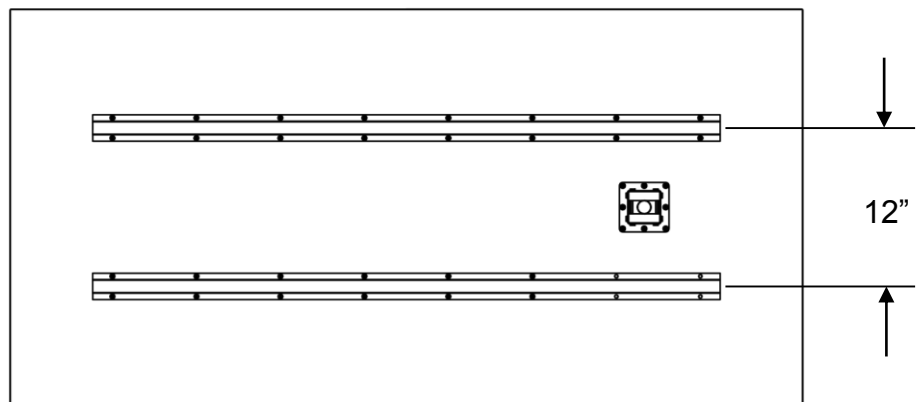

# Calibrate Standard Run-Offs Installation Instructions

## Rectangular Run-Off with Single Post Leg with or without Modesty

**Step 4:** Secure to adjacent supportive surface using flat plates and screws.

