



Calibrate Tackboard with Tool Rail Installation

Date	Page No.	Description of change	Name
02/03/2023	1-6	Released	S. Powers

Item	Replacement Part number	Circle Sheet Part Number	Description	Image
P1	RL-TRxx	RL-TRxx	Tool Rail	
P2	RH-WSFP1034	RH-WSFP1034	#10 x 3/4" long Flat Head Wood Screw	
P3	A-WMTBB	RA-WMTBB	Tackboard Brackets	

Calibrate Tackboard with Tool Rail Installation

Step 1 (for hutch mount): Center tool rail on hutch wall and secure with #10 x 3/4" long screws.

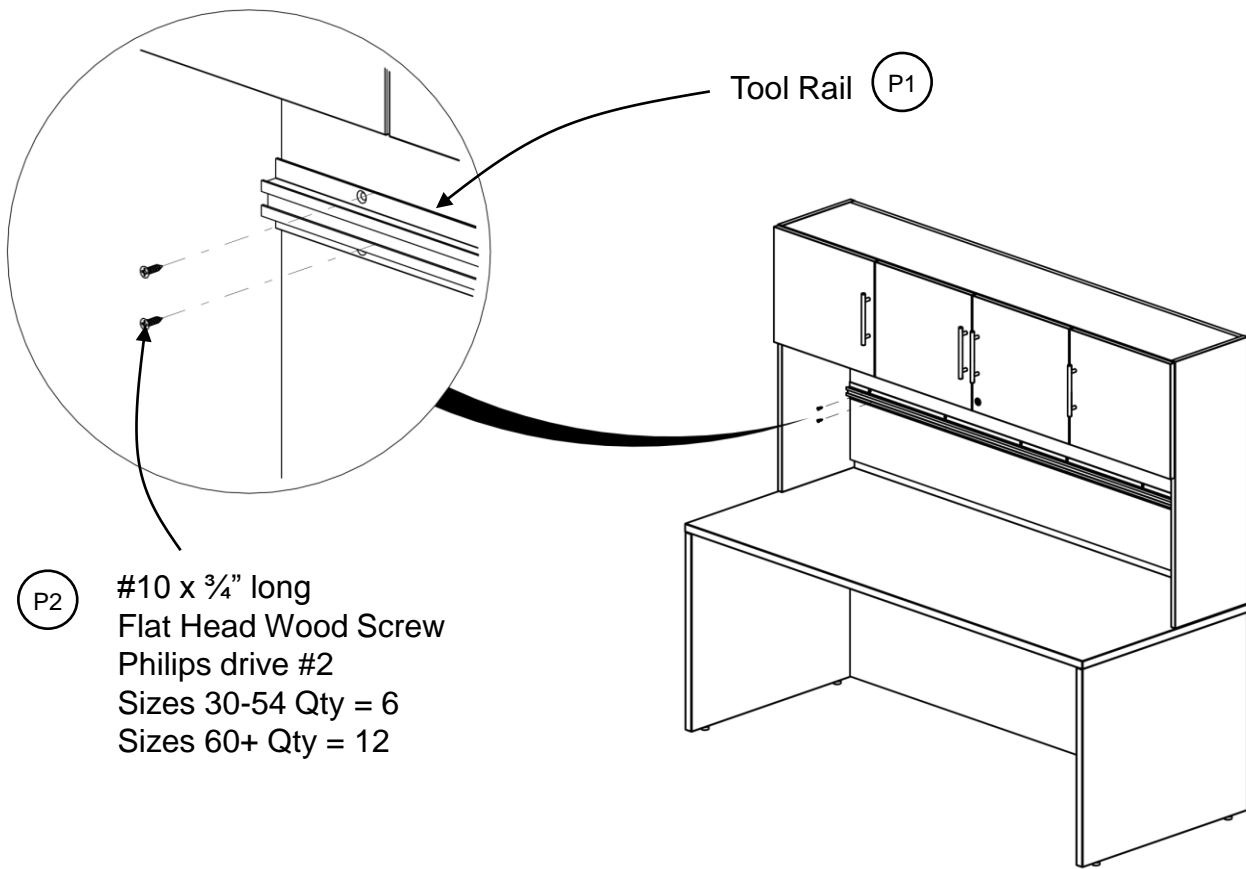

Step 1 (for wall mount): Secure tool rail (if required) on wall with #8 or #10 drywall screws (not included).

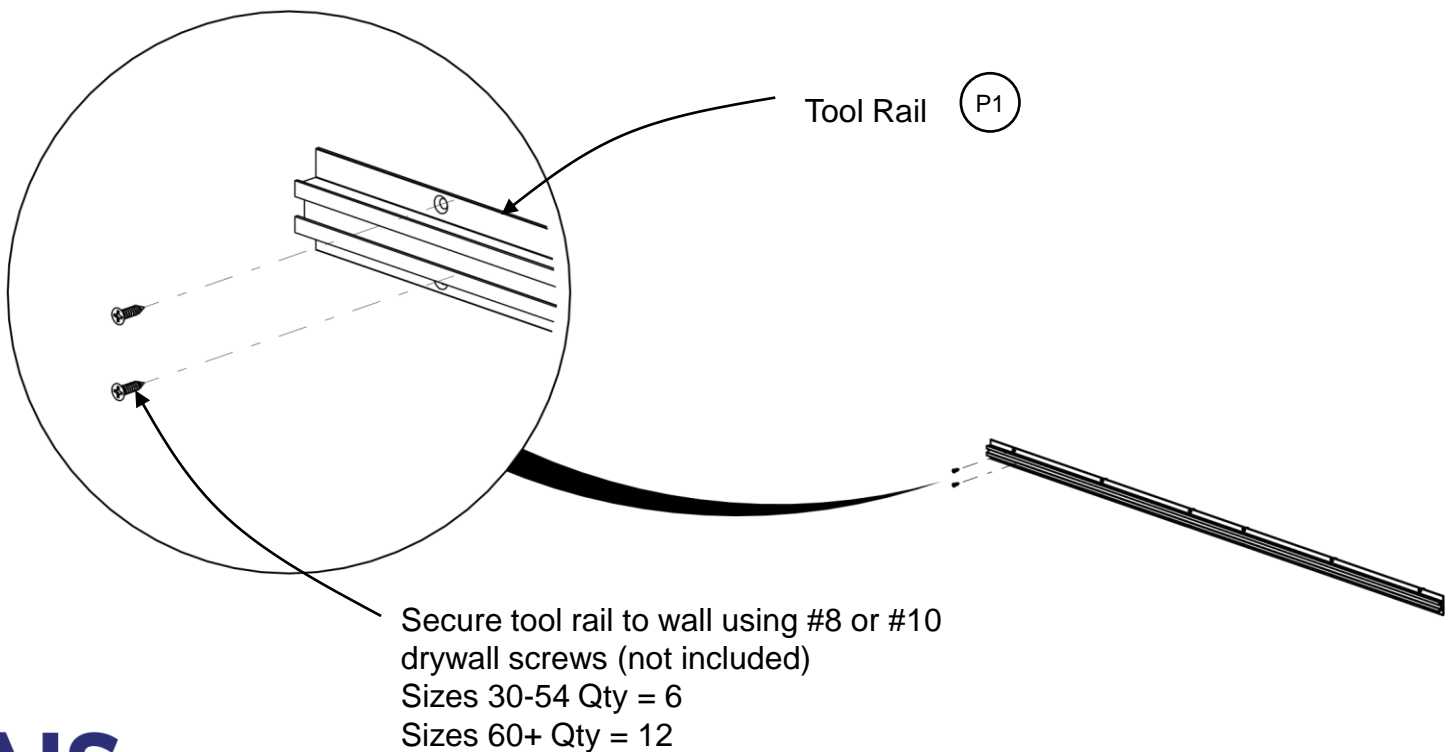

Calibrate Tackboard with Tool Rail Installation

Step 2: Position tackboard bracket onto the back side of the tackboard

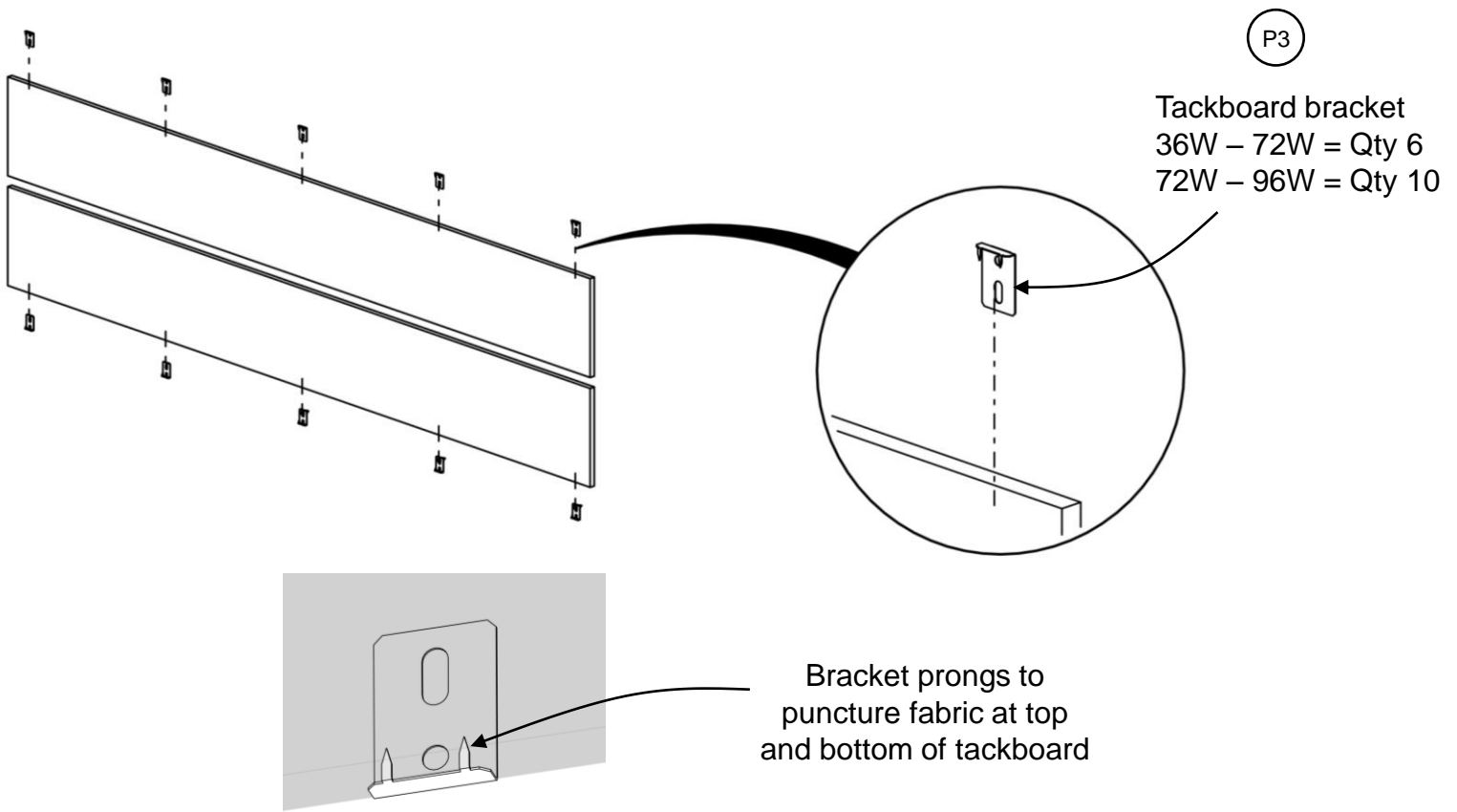

Step 3: Remove adhesive backing from brackets.

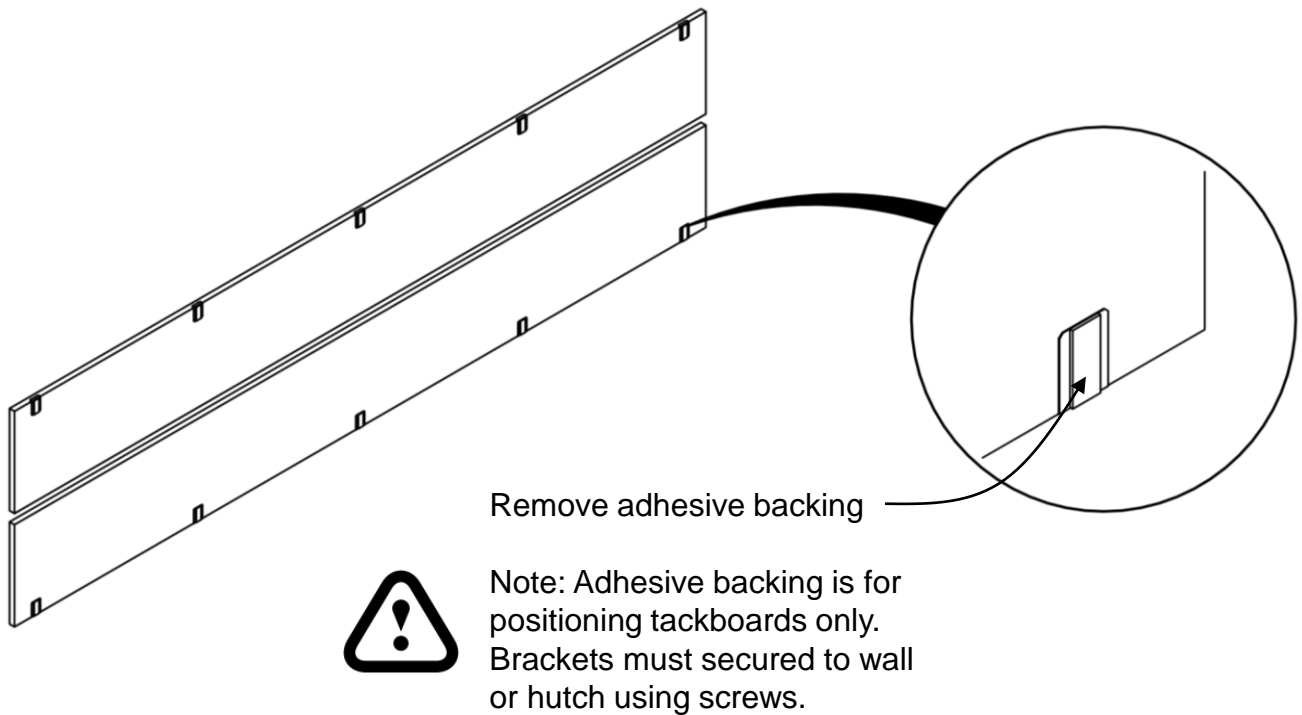

Calibrate Tackboard with Tool Rail Installation

Step 4: Position tackboards into the tool rail. Firmly press brackets up onto the wall making sure brackets are firmly adhered in place.

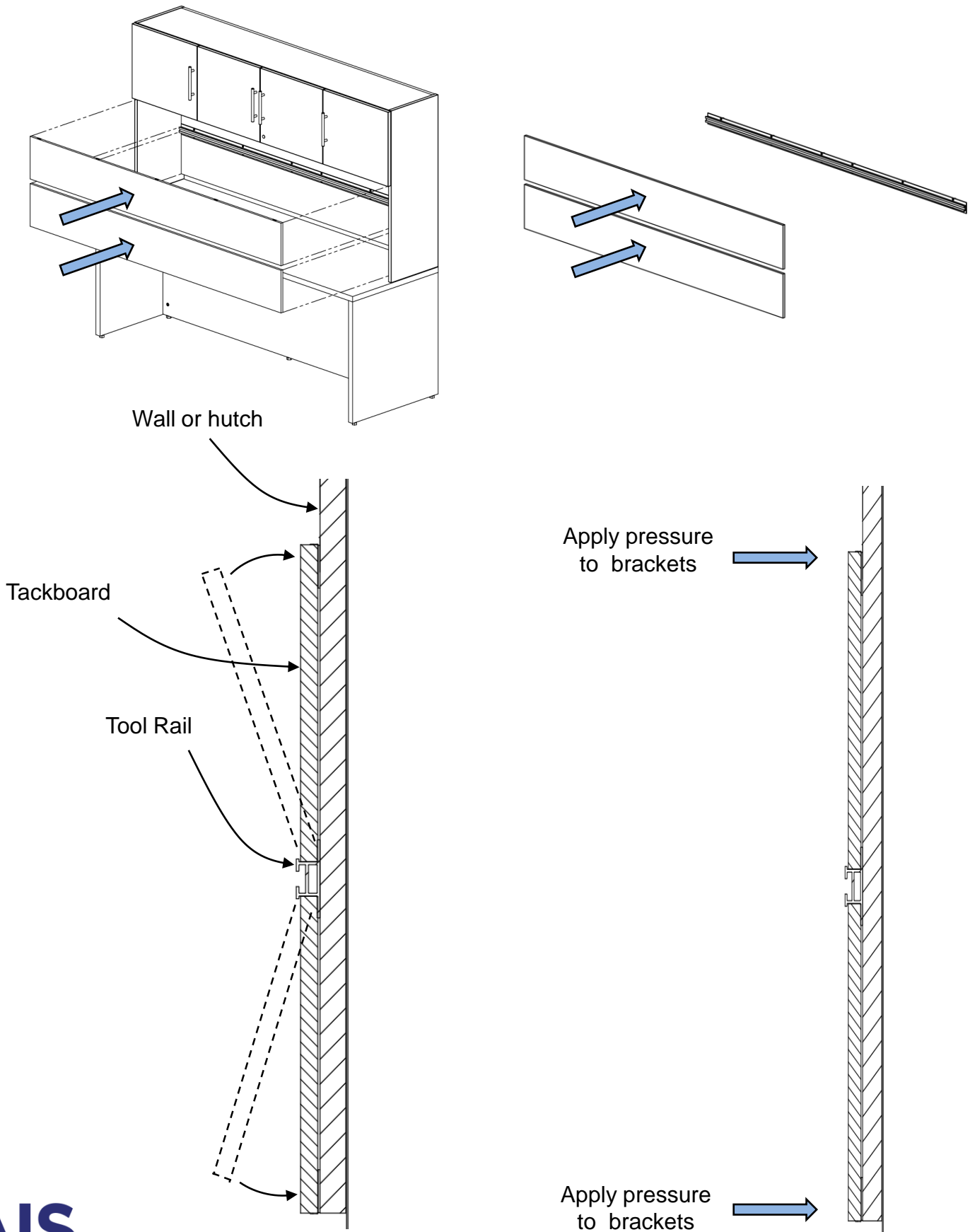

Calibrate Tackboard with Tool Rail Installation

Step 5: Remove tackboards from wall, making sure all brackets remain secure to the wall.



To remove tackboard, gently hold top of tackboard, making sure the tackboard is not being crushed. Then pull middle out first to disengage the bracket prongs.

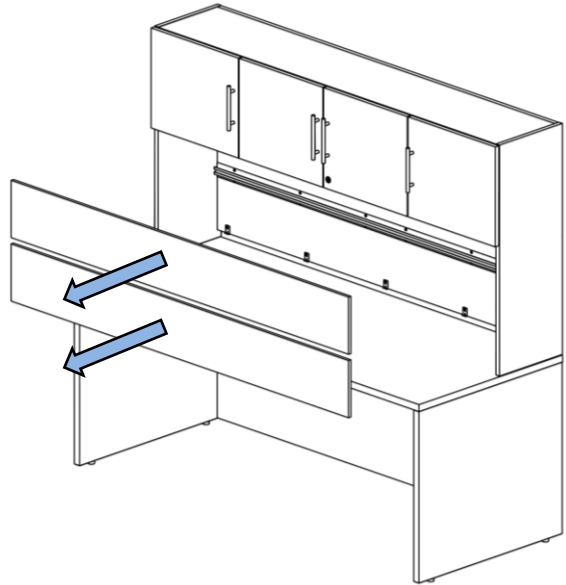
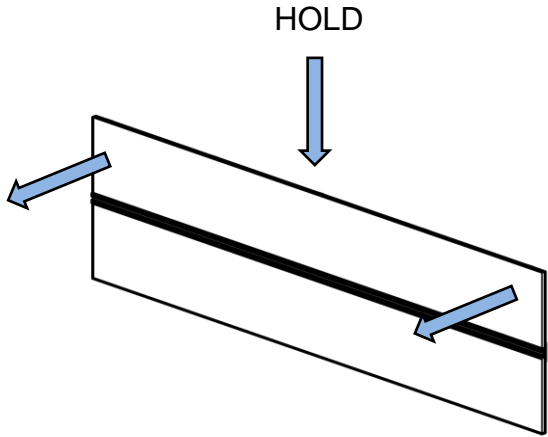

Step 6: Secure all brackets in place using #10 x 3/4" screws

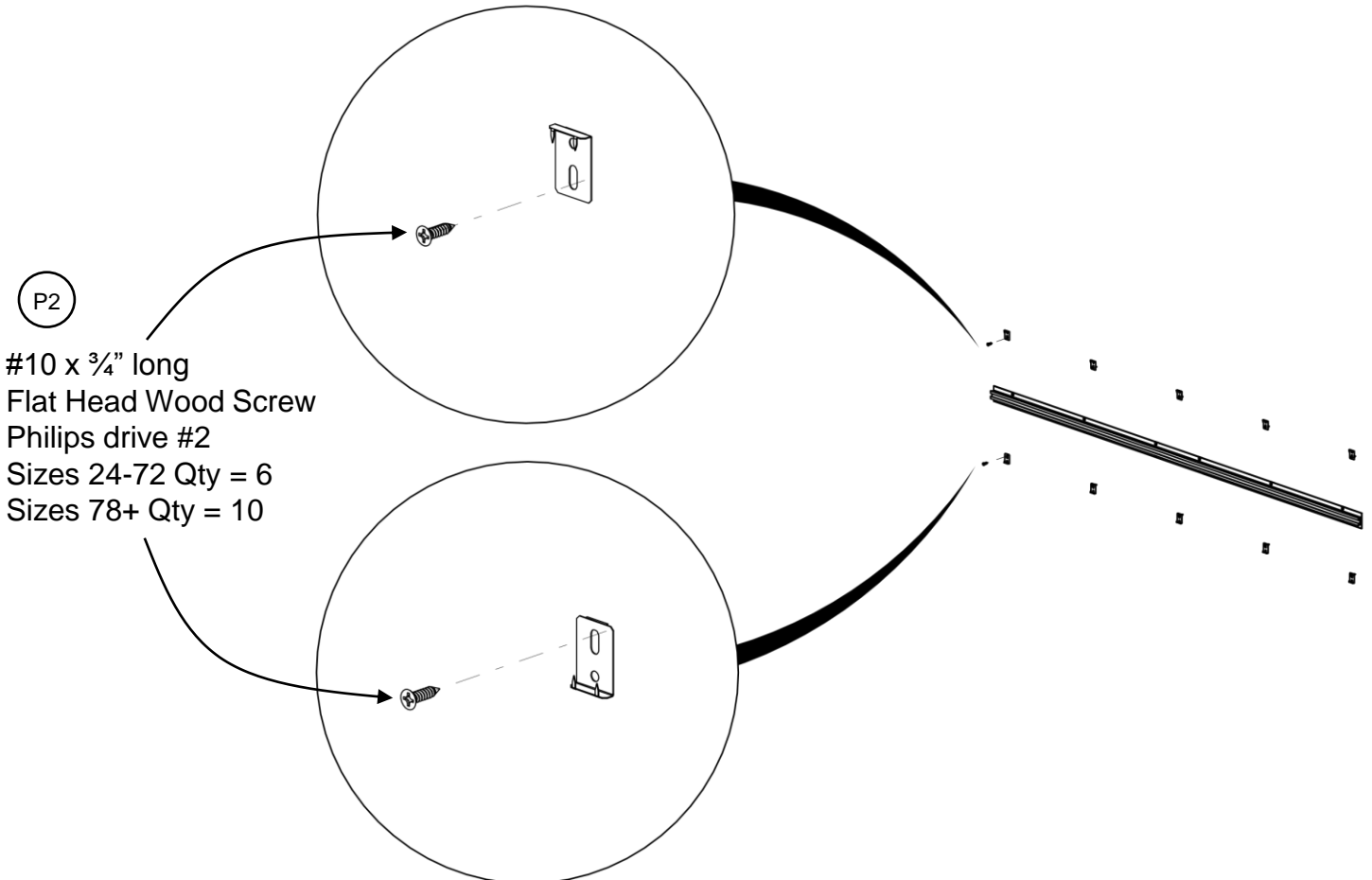

Calibrate Tackboard with Tool Rail Installation

Step 6: Re-install tackboard to brackets.

