













CaseWorks Installation Instructions

Date	Page No.	Description of change	Name
02/18/2025	1-13	Released	S. Powers
05/30/2025	1-21	Various updates	S. Powers
08/01/2025	9, 10, 14, 18	Added foot adjustment details. Added cleat mounting dimension 5 ¼". Updated toe kick clip installation details.	S. Powers
10/03/2025	12	Added sloped ADA sink cabinet	S. Powers
05/18/2026	13-14	Added L-shelf, vertical soffit, additional cleat mounting information and glides. Change screws from 1 ¼" to 1 3/8". Updated toe kick quantity note.	S. Powers

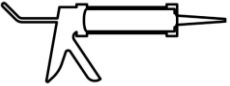
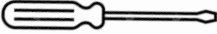

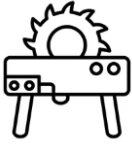

Recommended Tools

Stud finder 	Laser level 	Level 	Tape Measure 	Rubber Mallet 
Cordless Drill 	#2 Phillips insert bit 	3/16" drill bit 	Clamp 	General Purpose Adhesive and Caulk 
Slotted Screwdriver 	Double Sided Tape 	Painters Tape 		

Advanced Tools

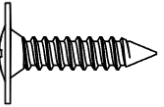
Circular saw 	Hole saw 	Jig saw 	Table saw 	
---	---	--	--	--

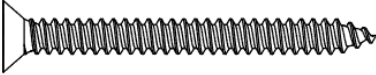
CaseWorks Installation Instructions

Supplied Hardware Screws			
Item	Replacement Part Number	Description	Image
P1	RH-SMBMTP17834B	#8 x 3/4" Modified Truss Head Screw	
P2	RH-01023979-i	#8 X 1 3/8" Flat Head Wood Screw	
P3	RH-01580111	#10 X 2" Flat Head Wood Screw	
P4	RH-WSZFP658B	#6 x 5/8" Flat Head Wood Screw	

CaseWorks Installation Instructions

*****READ ALL INSTRUCTIONS BEFORE STARTING INSTALLATION *****

IMPORTANT ASSEMBLY NOTES:

- Review the design spec layout prior to set up and staging of components.

• CAUTION!

- Verify the structural integrity of the wall is sufficient to support the wall mounted product.
- All mounting hardware (not included) should be securely fastened to the load bearing wall.
- MINIMUM REQUIRED WALL CONSTRUCTIONS:
 - Drywall with Metal Studs
 - Must be at least 25 ga. (0.015" min thk) 33 ksi steel studs 1.5" x 3.5"
 - Studs on maximum 24" centers.
 - Must be at least 5/8" thick Type X gypsum drywall (per ASTM C36, ASTM C1396 and CAN/USA-A82.27M)
 - 16 ga (0.063") metal banding, 6" wide min, as defined per installation drawing package.
 - Drywall with Wood Studs
 - Stud grade SPF, DF-L or Hem-Fir 1.5" x 3.5"
 - Studs on maximum 24" centers.
 - Must be at least 5/8" thick Type X gypsum drywall (per ASTM C36, ASTM C1396 and CAN/USA-A82.27M)
 - Wood blocking, 6" wide min, as defined per installation drawing package.

• WARNING: CRUSH HAZARD!

- Failure to properly secure cabinet could result in personal injury.
- Read all instructions for your product mounting recommendations.
- Verify all walls meet the minimum construction requirements before beginning your installation.
- Install ALL fasteners required.
- Mounting hardware (toggle bolt anchors, toggle bolts, screws, etc.) to be verified by the Building's Engineer of Record, even if provided by AIS. Install mounting hardware per the hardware manufacturers instructions.

CaseWorks Installation Instructions

*****READ ALL INSTRUCTIONS BEFORE STARTING INSTALLATION *****

IMPORTANT ASSEMBLY NOTES:

- Note location of plumbing and electrical location and make necessary cutouts to the required cabinet.
- Recommended order of installation:
 - Base cabinets
 - Overheads
 - Filler panels
 - Toe kicks
 - Worksurfaces
 - Backsplashes
- Cleat Mounted Cabinet:
 - All base and wall mounted cabinets are shipped with the top half cleat installed on the upper back side of cabinets and a spacer block at the bottom.
 - Tall cabinets are not cleat mounted.
- Extended sides options:
 - All cabinets can be configured to extend the sides flush to the wall, hiding the cleat gap, to create a seamless look.
 - When mounting multiple cabinets on one cleat, it's best to have the extended sides at each end of the run.

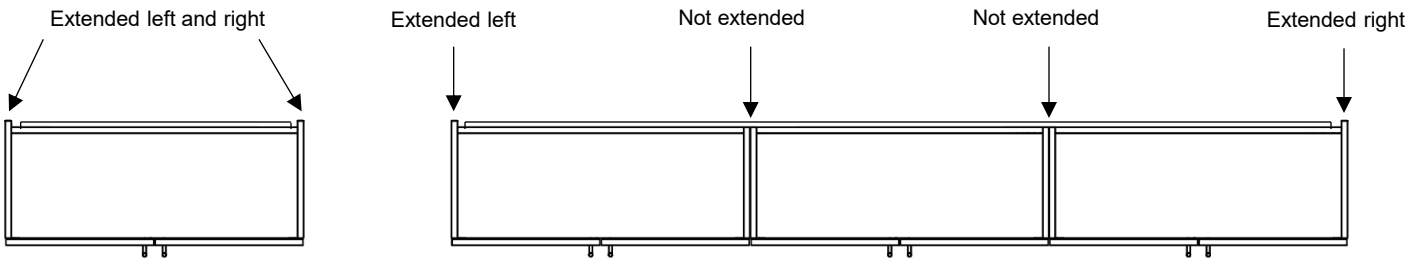

- Base options include a choice for:

- All feet
- Front feet only (wall cleat mounting required, use wall to secure and level cabinet)
- No feet (wall cleat mounting required)

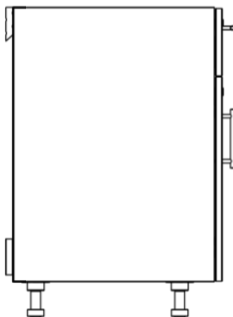

All feet
(Qty 4 or 6)

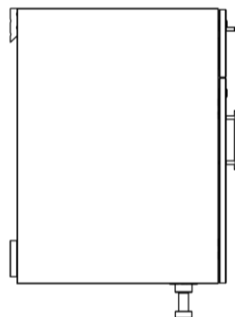

Front feet only
(Qty 2 or 3)

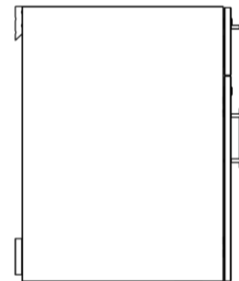

No feet

CaseWorks Installation Instructions

Step 1: Carefully unbox cabinets. Make sure all required hardware is accounted for. Review the design spec and stage cabinets according to layout. Remove any doors, drawers and shelving if applicable. Take note of any plumbing or electrical. If necessary, make any required cutouts in the back of the base cabinets before installing.

Note:

Grain direction on door and drawer fronts are matched. Make sure to organize fronts in a manner to be correctly re-installed later.

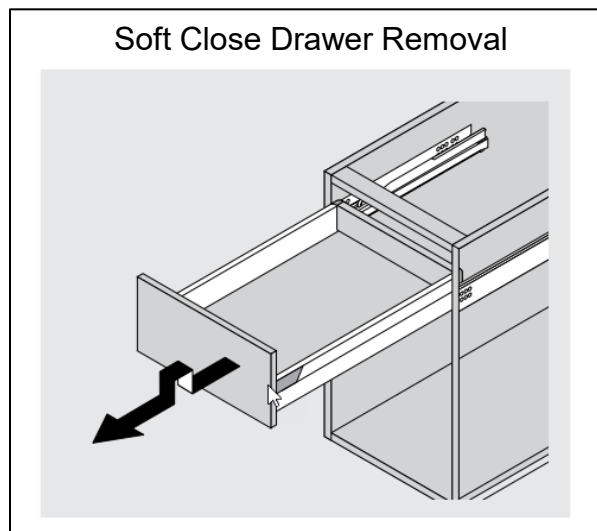
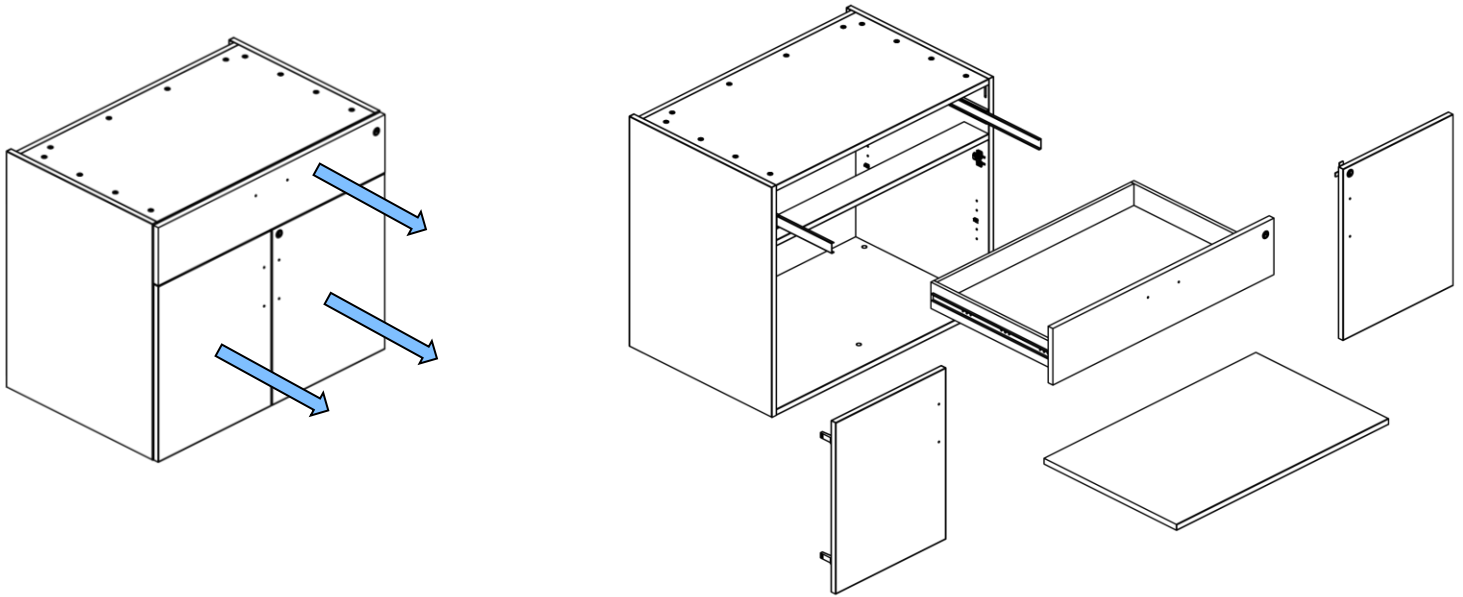

CaseWorks Installation Instructions

Step 2a (for units with feet only): Prepare to install feet by carefully flipping the unit onto the back side.

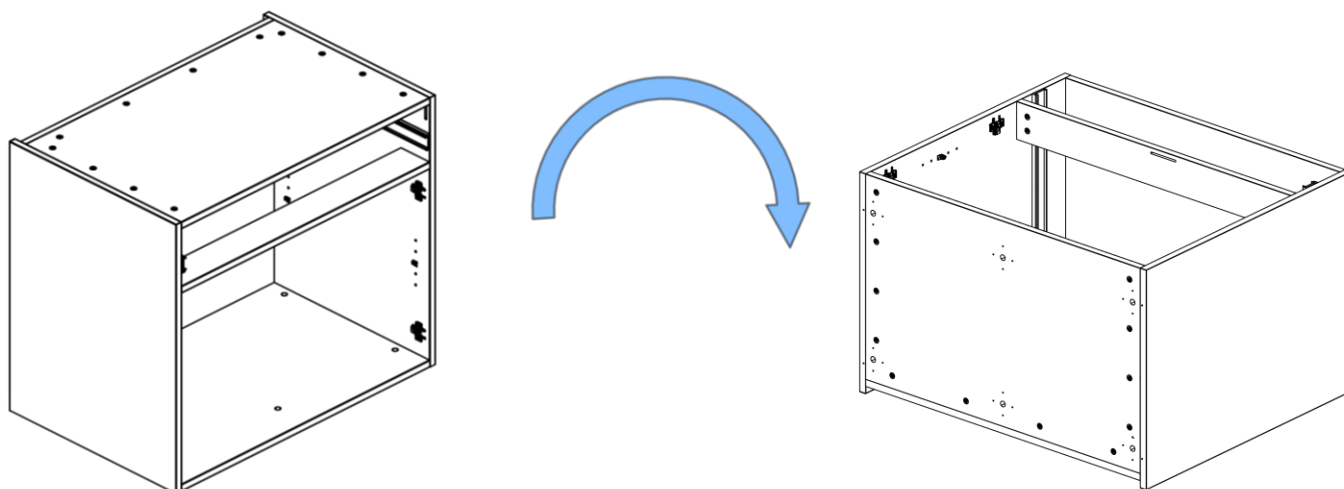

Step 2b (appliance garage or ADA sink only): Flip the unit onto the back side. Remove and discard the shipping support panel.

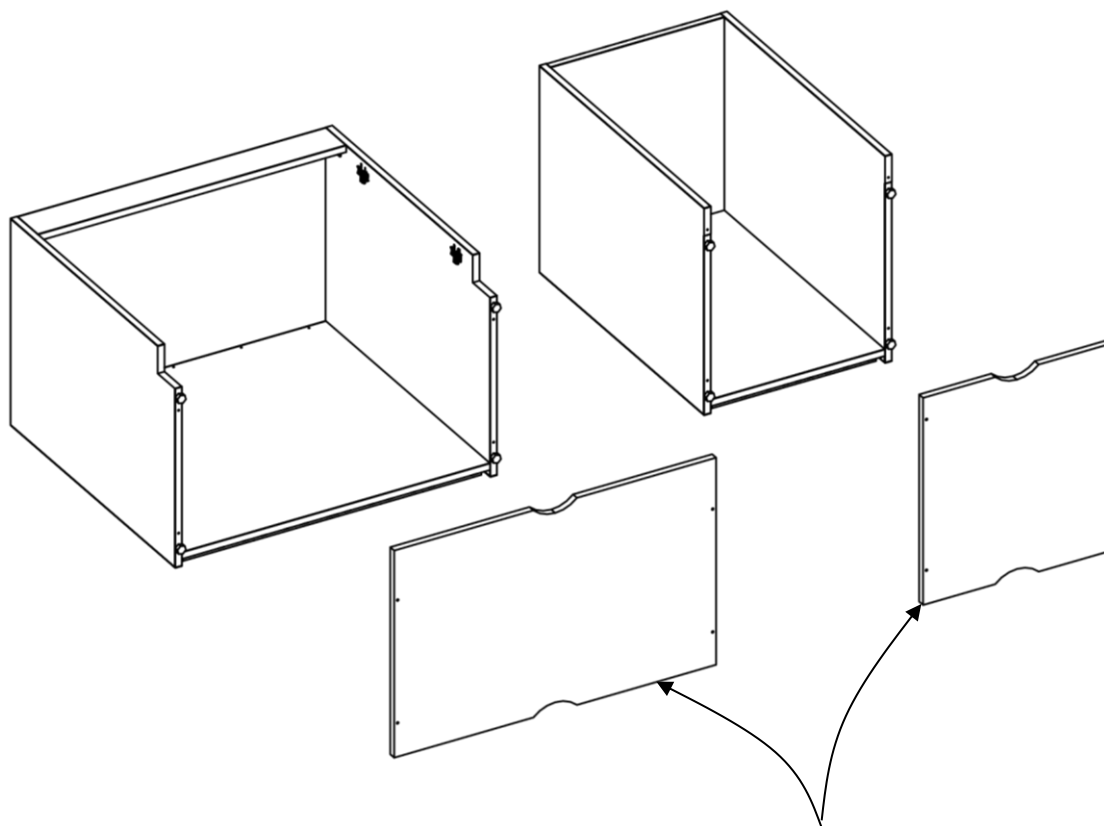

Remove and discard shipping support panel

CaseWorks Installation Instructions

Step 2c (for units with glides only): Flip the unit onto the back side and install glide inserts and glides. Units with glides include appliance garage, ADA sink cabinets, ADA double door cabinets and end panels.

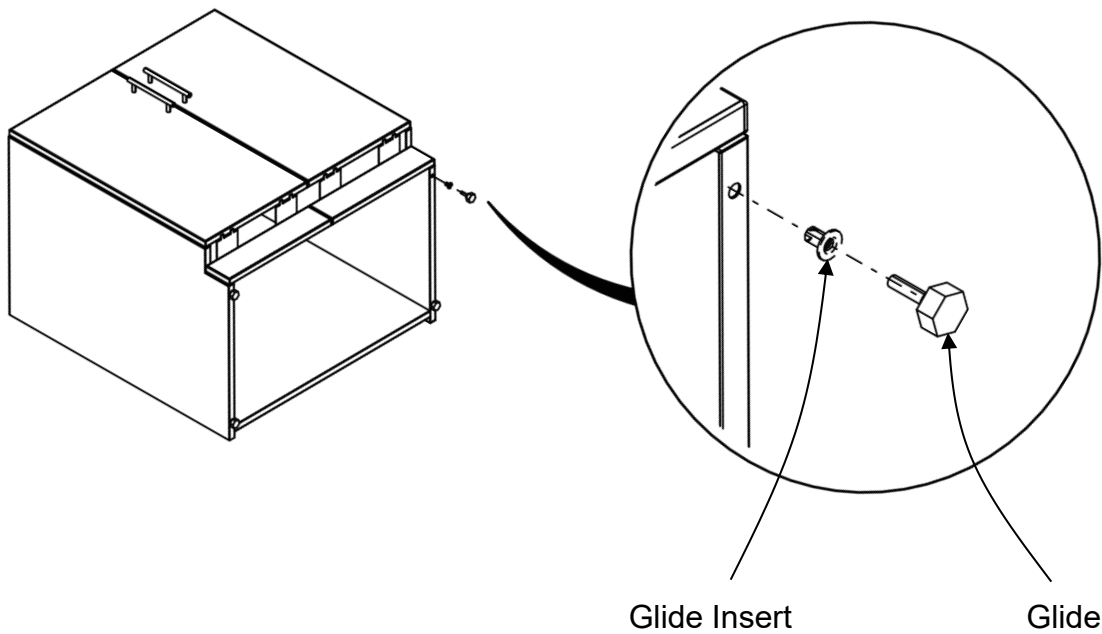
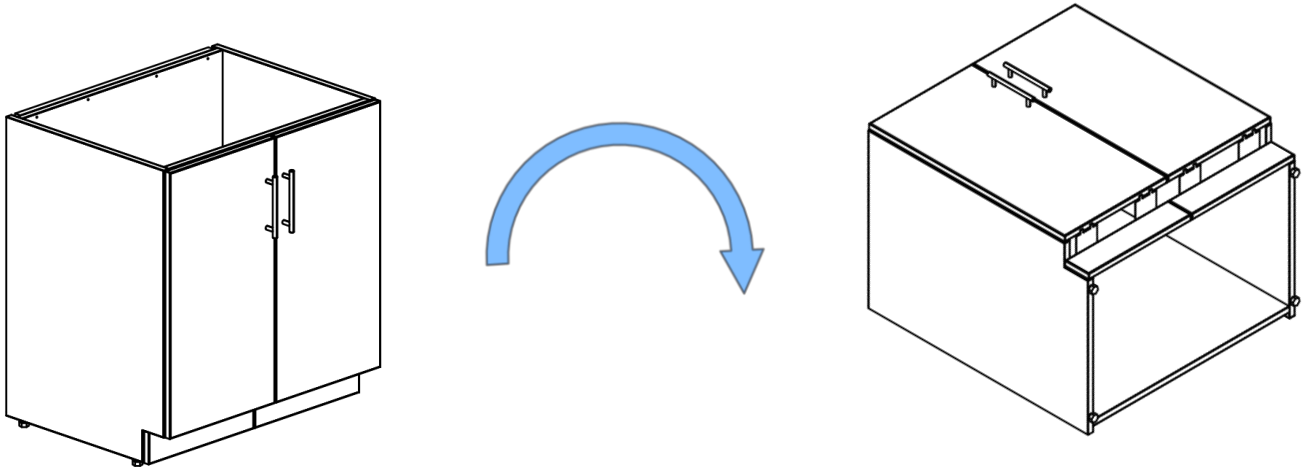

CaseWorks Installation Instructions

Step 3 (for units with feet): Align the foot base with the holes in the cabinet and secure in place.

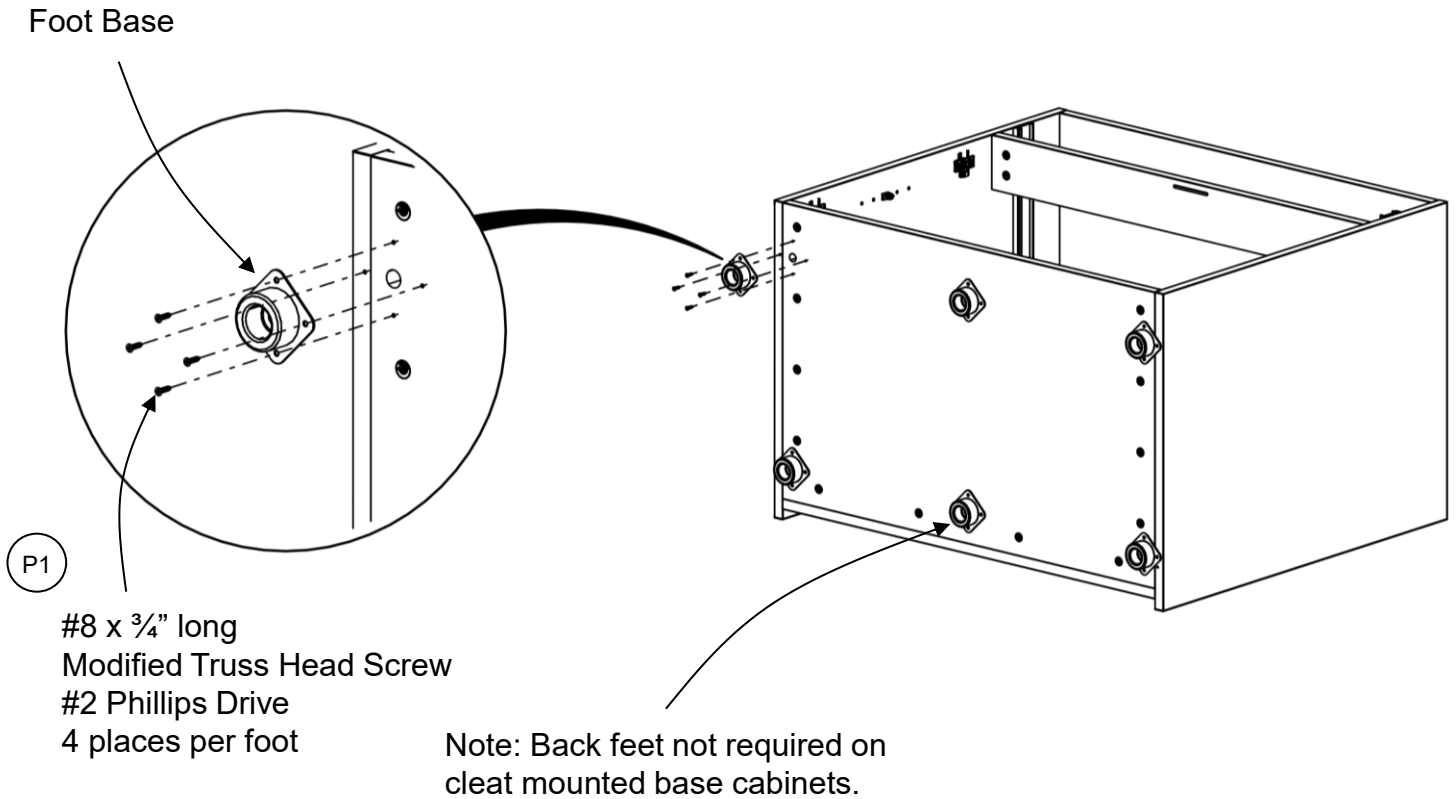

Step 4 (for units with feet): Gently use a soft mallet to tap the foot posts into the foot bases. Check that they fit securely before you turn the cabinet over.

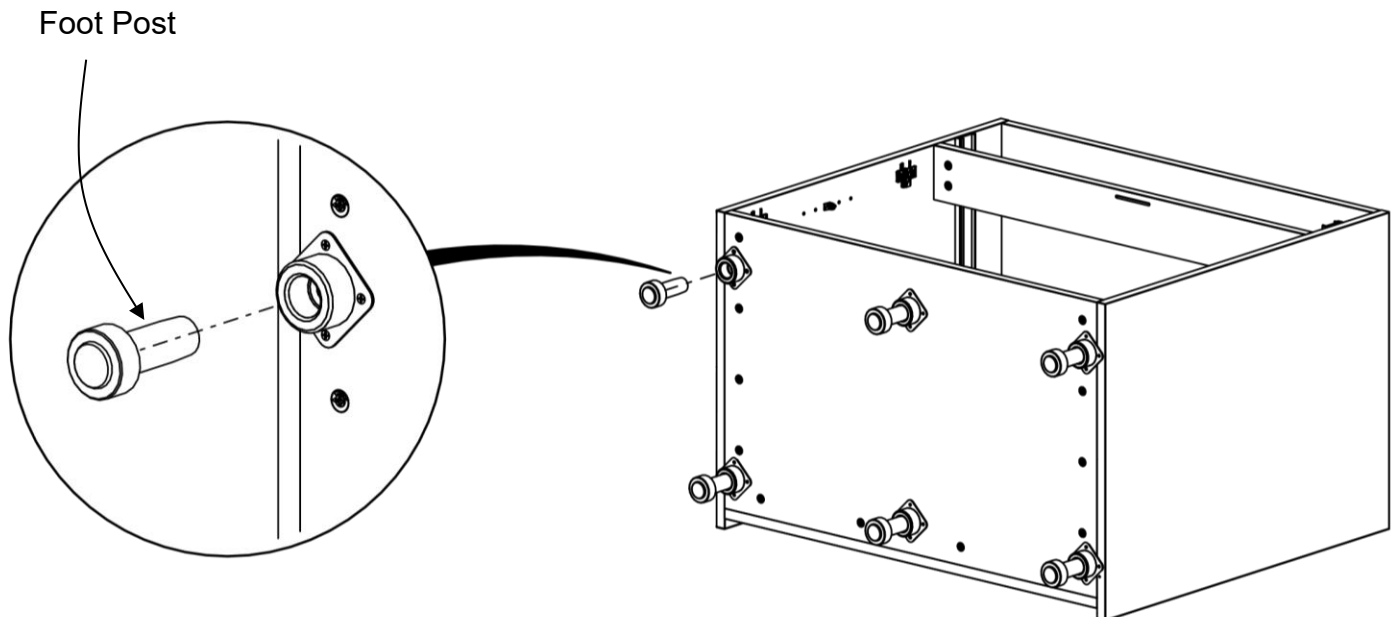

CaseWorks Installation Instructions

Step 5 (for units with feet): Carefully flip unit back to right side up and prepare to hang on the wall.

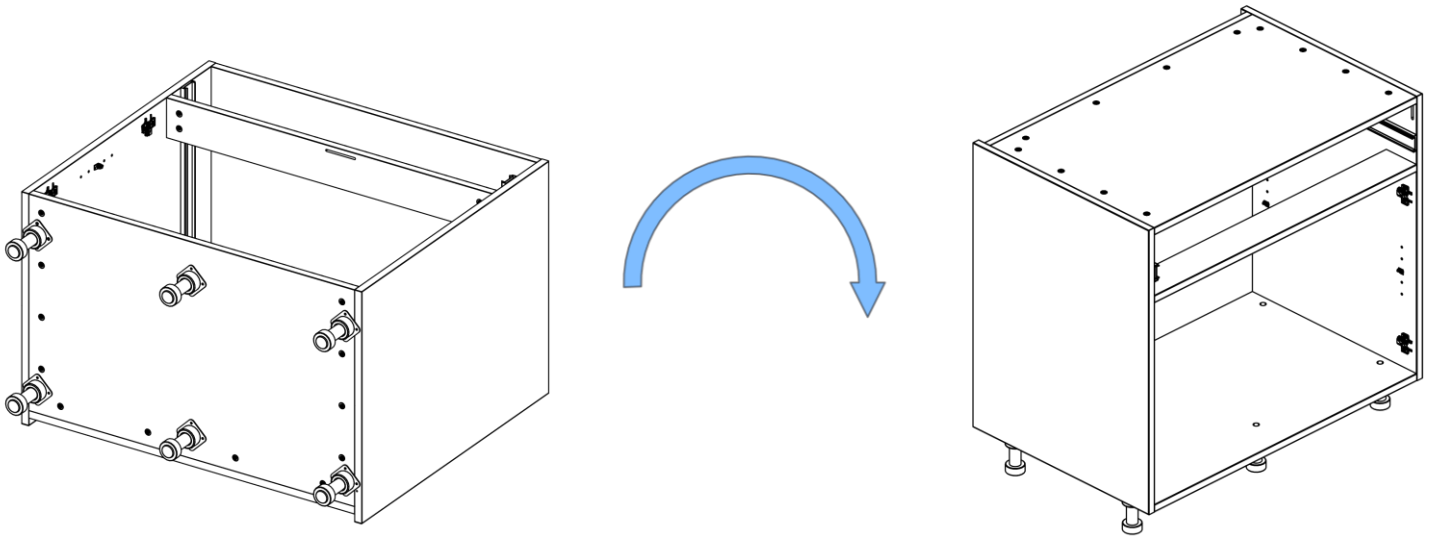

Step 6a (for units with feet): Locate the highest and lowest points of the floor along base cabinet runs. Star levelling at the highest end, space for toe kick should never be less than 4" high.

Step 6b (for units with feet): Level units by adjusting the metal feet. Then, gang units together using ganging screws.

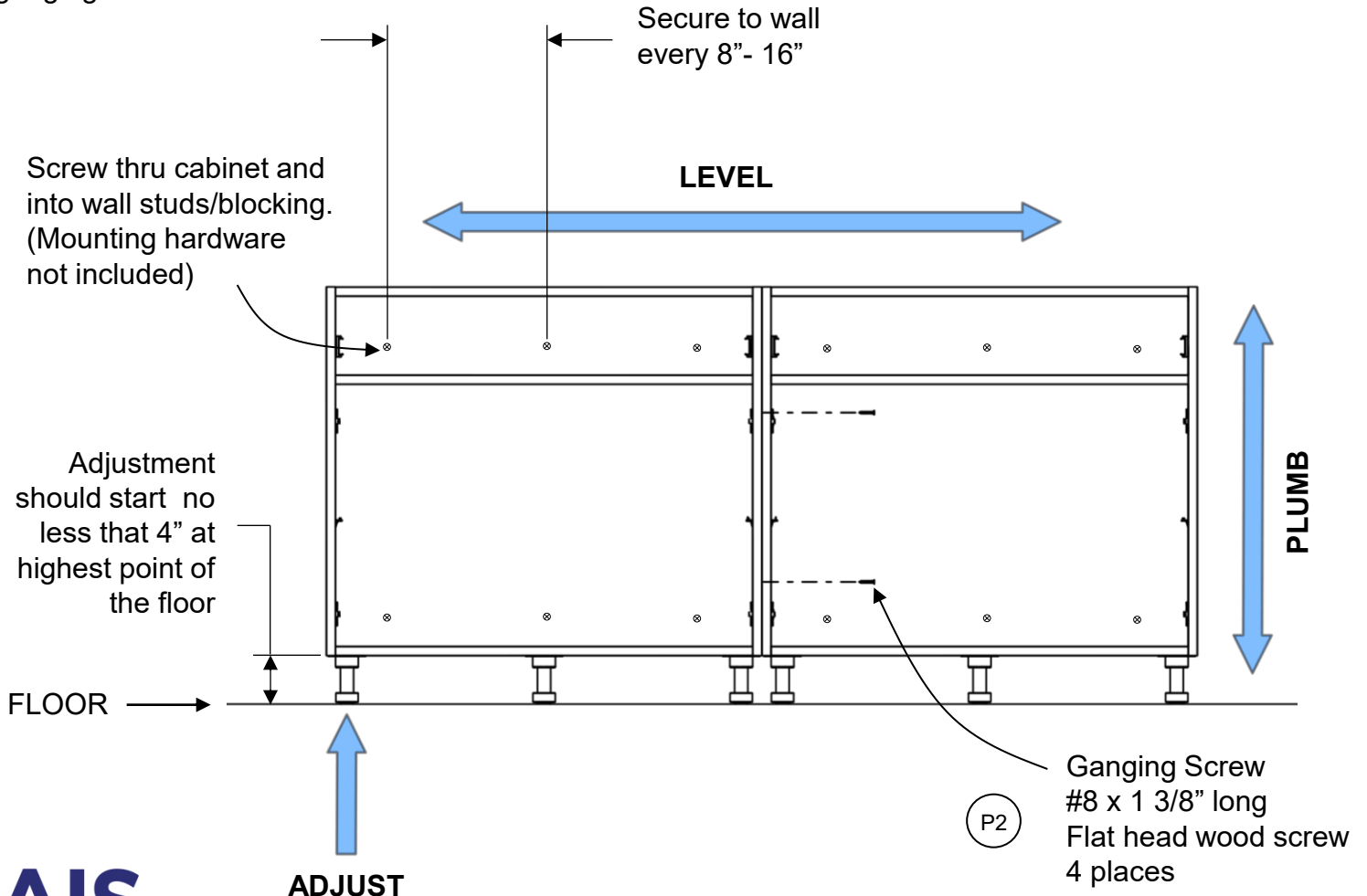

CaseWorks Installation Instructions

Step 6 (cont'd): Adjust feet as needed to level unit.

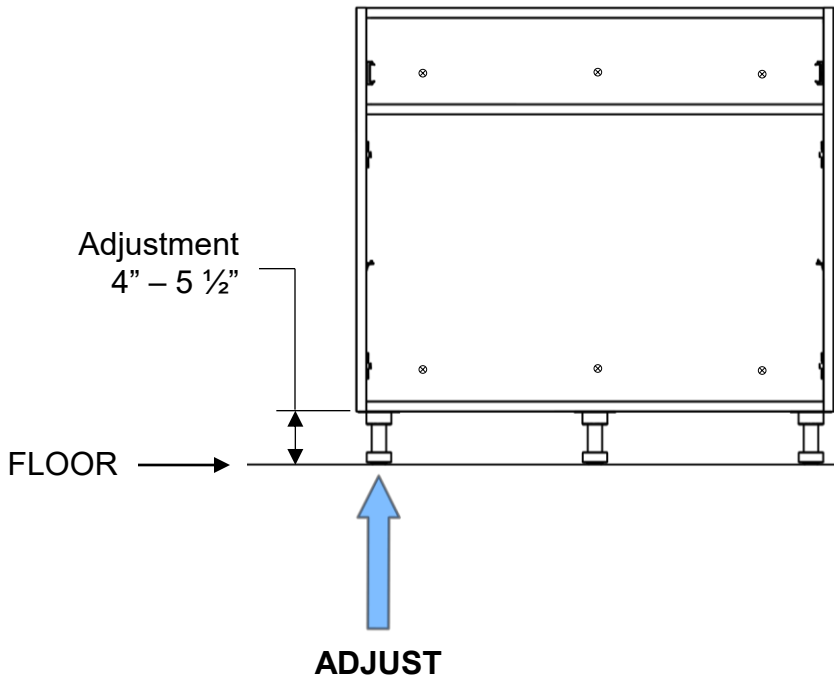

If height adjustment more than 5 1/2" is necessary, remove glide and reverse the glide stem for up to 6 3/4" of height adjustment.

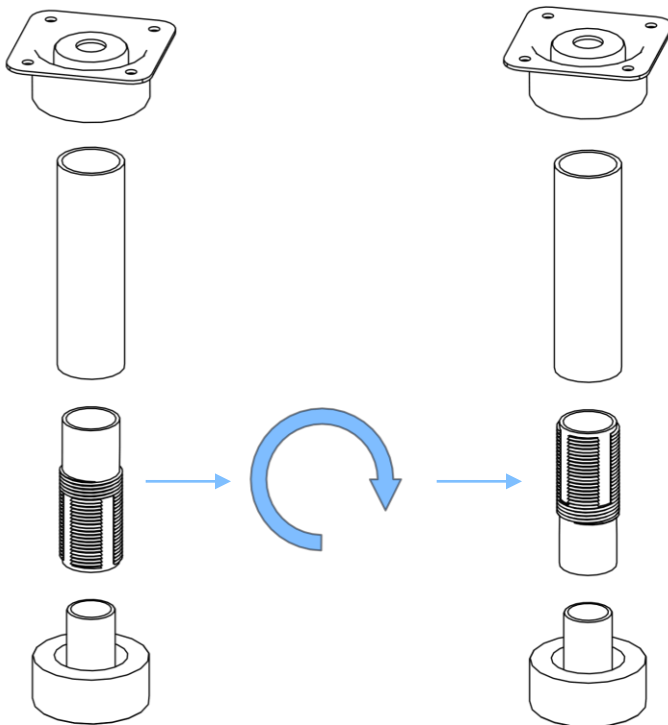

Use a wide flat head screwdriver to adjust foot glide height.

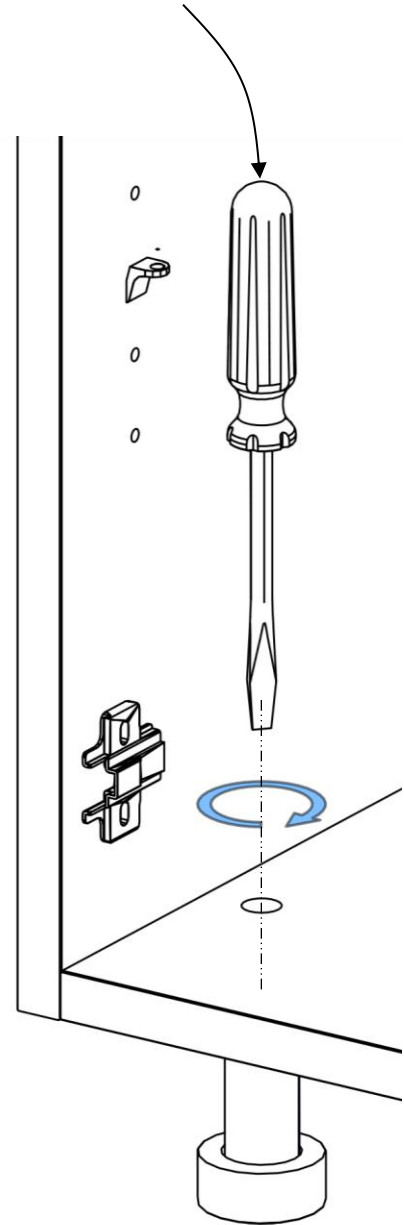

CaseWorks Installation Instructions

Step 7: Determine if cabinets require cleat mounting.

Base cabinet options:

- All base cabinets include a choice for:
 - All feet
 - Front feet only (wall cleat mounting required)
 - No feet (wall cleat mounting required)

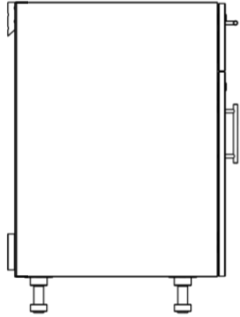

All feet
(Cleat mounting not required)

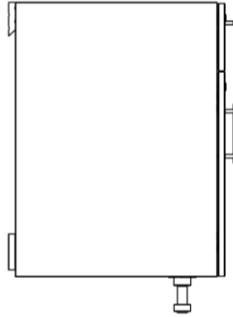

Front feet only
(Cleat mounting required)

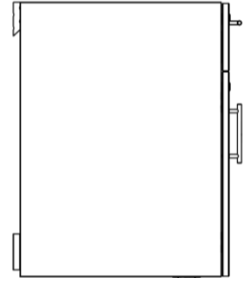

No feet
(cleat mounting required)

Cleat mounting:

- Base cabinets include one top half cleat. (Tall storage cabinets are not cleat mounted)
- Wall cleats are ordered separately and are available in 48", 72" and 96" lengths.
- Cleat mounting is option for base cabinets and is not an option for tall storage cabinets.
- Wall cleats can be field cut to the required length. The required length is 2 ½" less the nominal length.
- For ease of installation, adjacent cabinets should use a shared wall cleat.

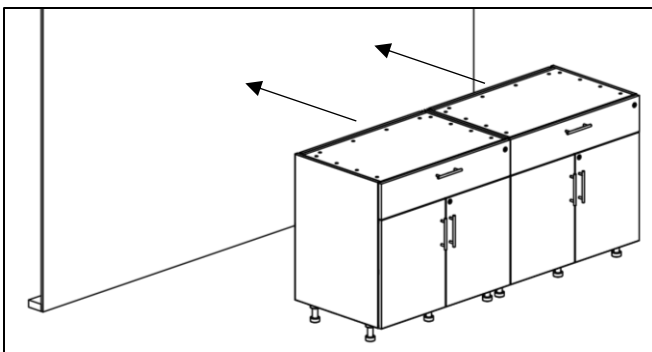

All feet
(Cleat mount not required)

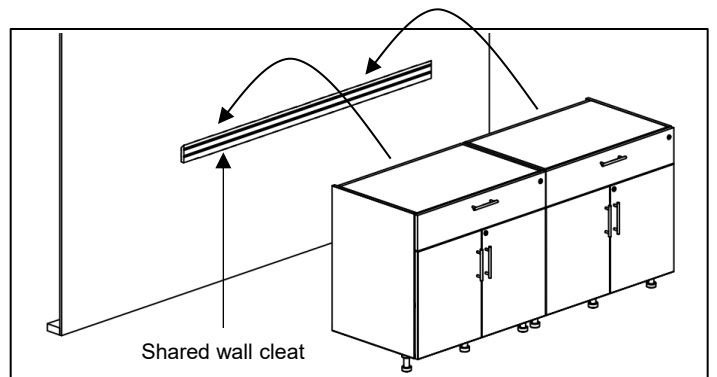

Front or no feet
(Cleat mount required)

CaseWorks Installation Instructions

Step 8 (for units with wall mounted cleats): Cut wall cleats to length per the design spec. Install bottom cleats to wall, making sure the cleats are level. (mounting hardware not included)



Customer must ensure structural integrity of the wall is sufficient to support the wall mounted product. All wall mounting hardware (not included) should be securely fastened to the load bearing wall.

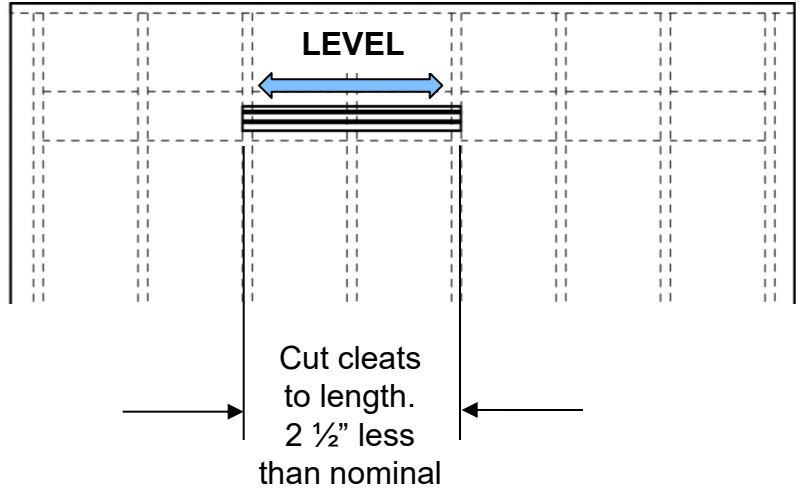
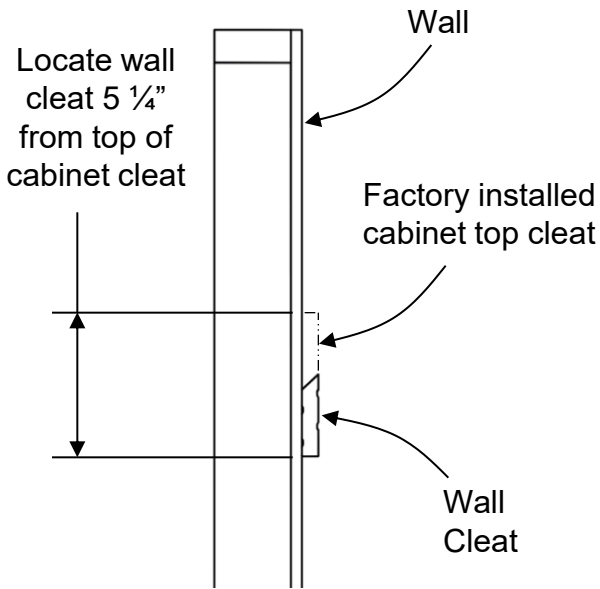

Step 8 (for units with wall mounted cleats): Hang units onto bottom cleats.

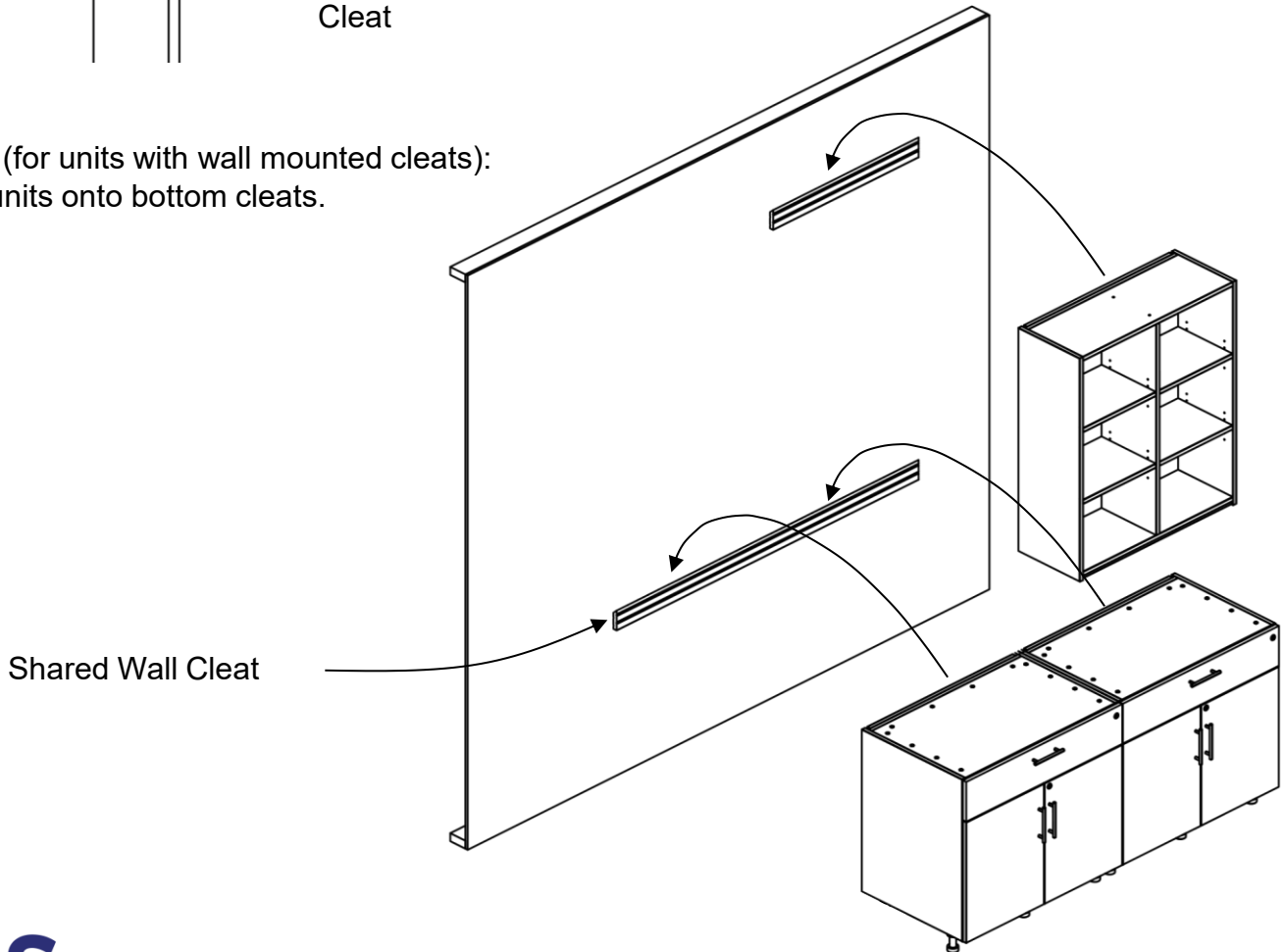

CaseWorks Installation Instructions

Step 9 (for units with wall mounted cleats):

- Make sure all units are level and plumb.
- For base cabinets, adjust feet flush to floor.
- Using clamps, pre-drill holes and gang units together with #8 x 1 3/8" screws.
- Secure to wall cleats.(mounting hardware not included)

Screw thru overhead into wall cleat in 2 locations.
Or, secure to wall studs where possible.
(Mounting hardware not included)

LEVEL OVERHEAD



Screw thru overhead cabinet strapping and into wall studs/blocking in 2 locations.
(Mounting hardware not included)

LEVEL BASE



Screw thru base into wall cleat in 2 locations.
Or, secure to wall studs where possible
(Mounting hardware not included)

Screw thru base cabinet strapping and into wall studs/blocking.
(Mounting hardware not included)

FLOOR →



ADJUST

Cleat mounted base cabinets have front feet only

(P2) Ganging Screw
#8 x 1 3/8" long
Flat head wood screw
4 places

(P2) Ganging Screw
#8 x 1 3/8" long
Flat head wood screw
4 places

PLUMB

PLUMB

CaseWorks Installation Instructions

Step 9a (for L-shelf units): Install dowel pins into shelf panels.

5/16" x 1 3/8" long
Dowel Pin
24W – 30W = Qty 2
31W – 48W = Qty 3
49W – 60W = Qty 4

Shelf Panel
Sizes 12H = Qty 1
Sizes 24H – 30H = Qty 2
Sizes 36H and 42H = Qty 3

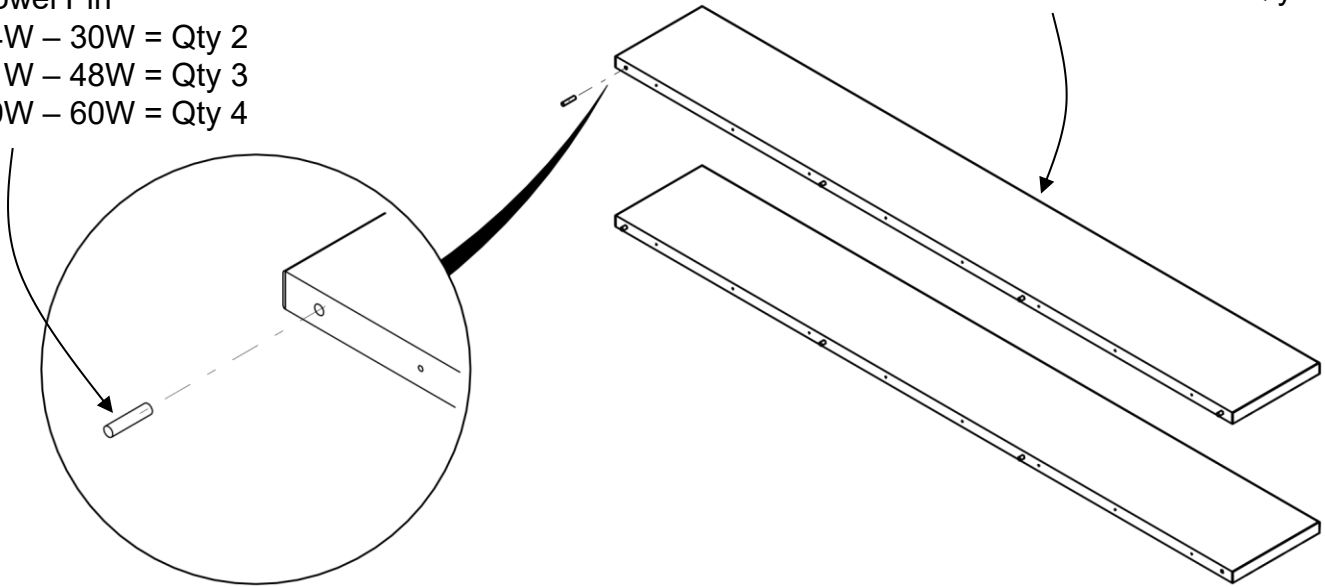

Step 9b (for L-shelf units): Align dowel pins in shelf panels to back panel.

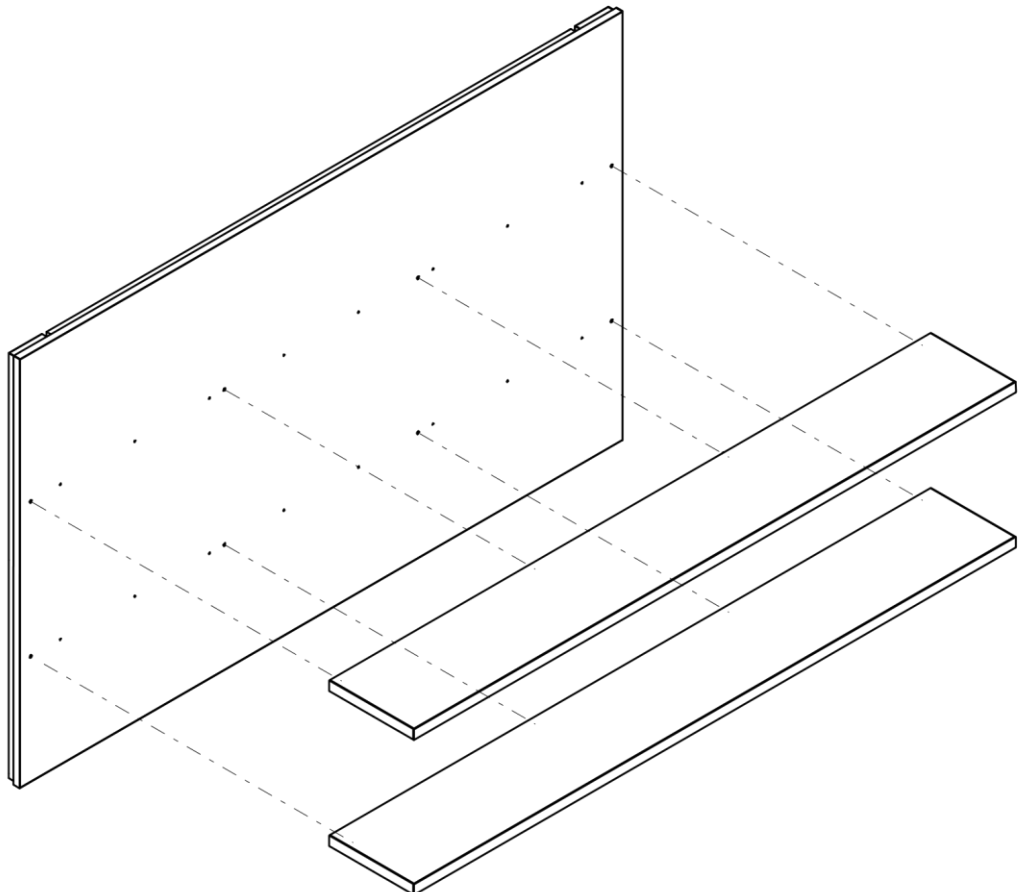

CaseWorks Installation Instructions

Step 9c (for L-shelf units): Secure shelf panels to back panel using #8 x 1 3/8" screws.

#8 x 4" long
Flanged Round Head Wood Screw
24W – 30W = Qty 3
31W – 42W = Qty 4
43W - 48W = Qty 5
49W – 60W = Qty 6

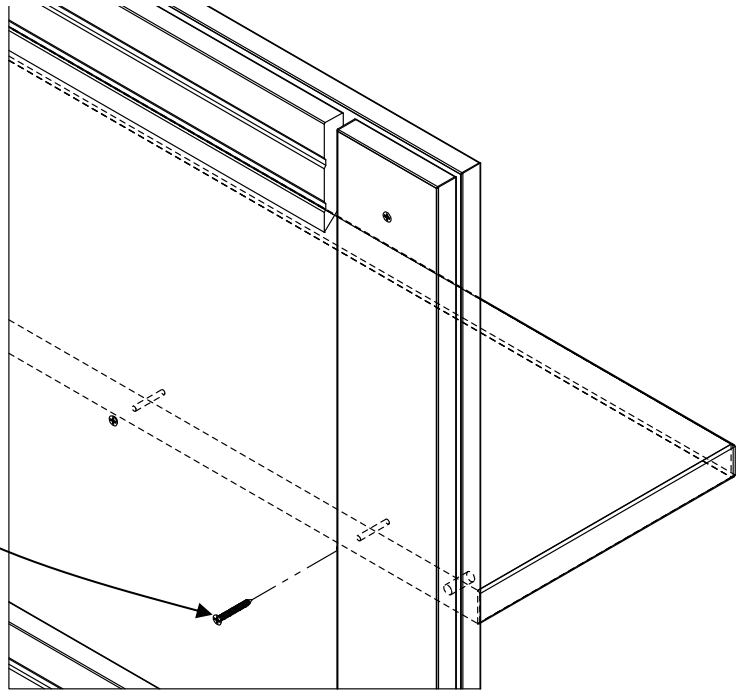

Step 9d (for L-shelf units): If using a continuous cleat, remove back panels, as necessary.

Do not remove panels
on exposed ends

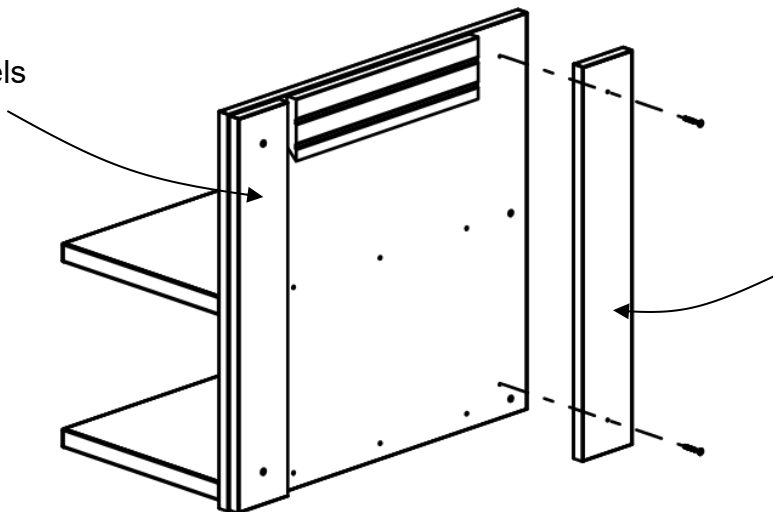

Remove panels when
mounting on a
continuous cleat.

CaseWorks Installation Instructions

Step 9d (for L-shelf units): Hang L-Shelf assembly onto the wall mounted wood cleats.

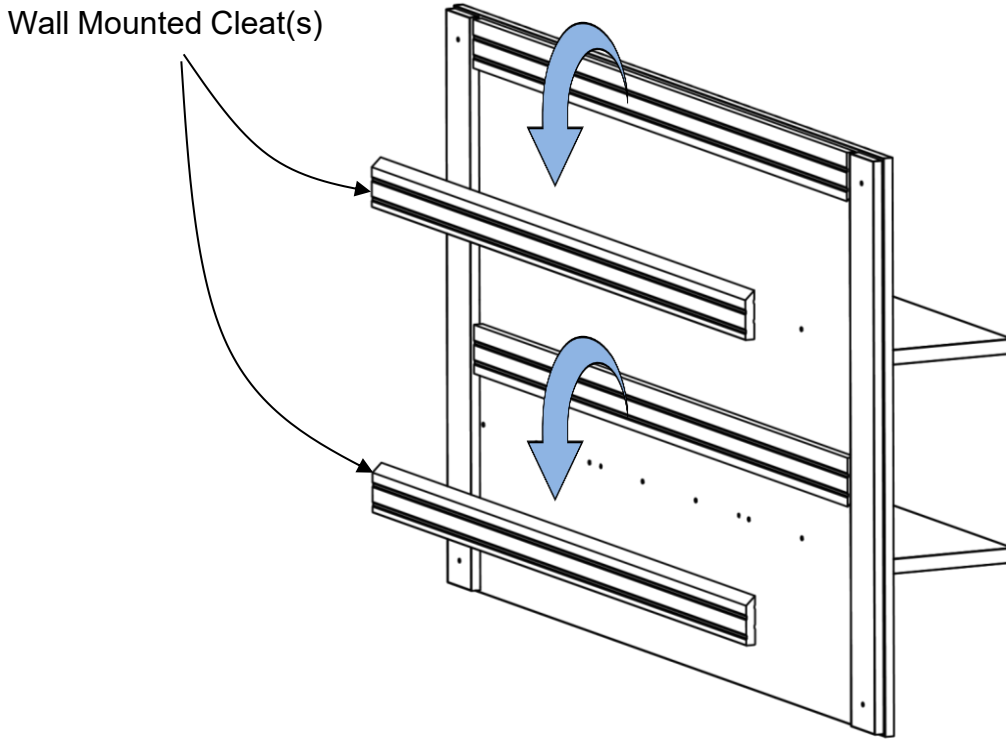

Step 9e (for L-shelf units): Secure L-Shelf assembly to the wall mounted wood cleats.

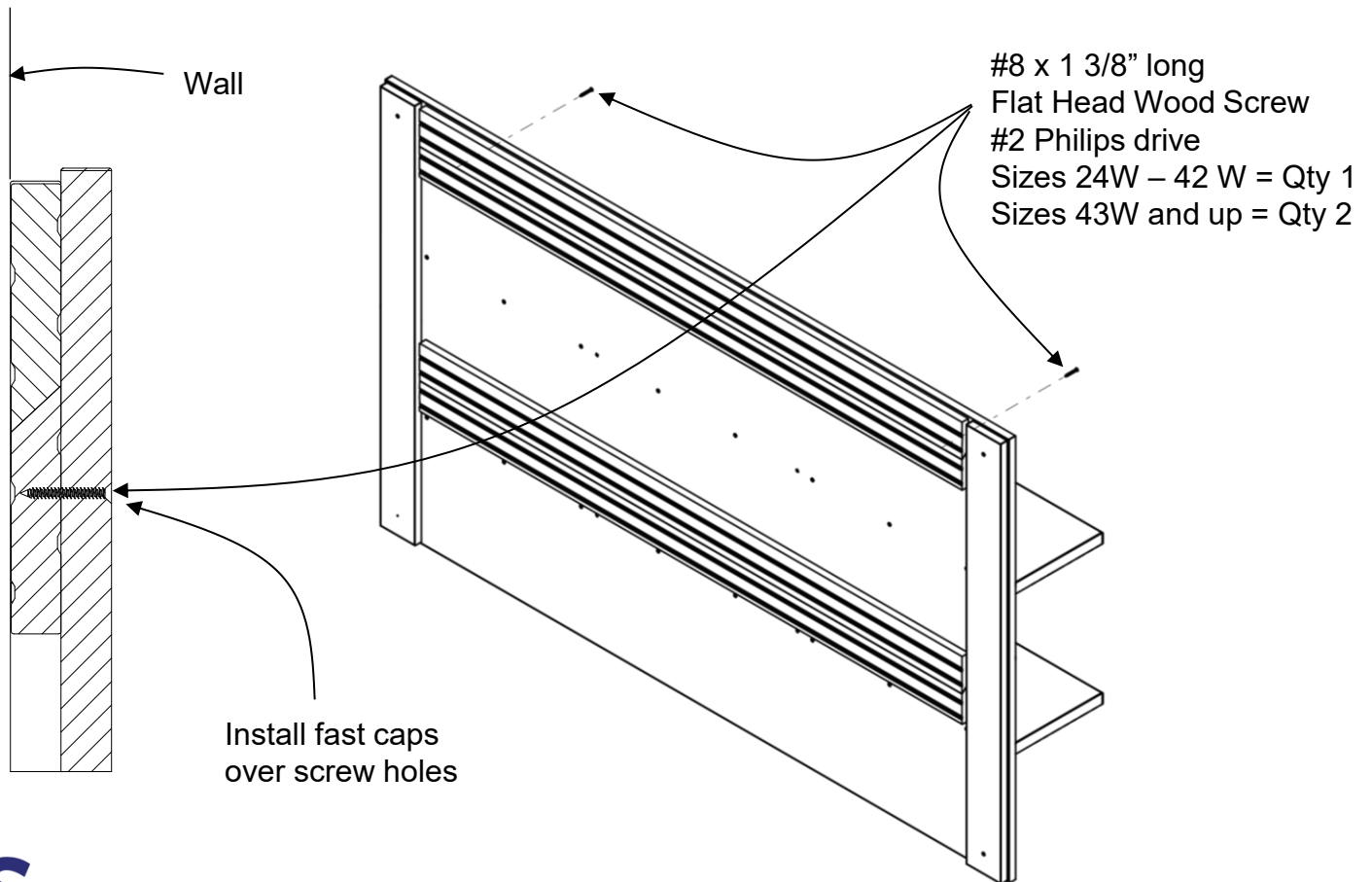

CaseWorks Installation Instructions

Step 10 (securing cleat mounted sloped ADA sink cabinets only):

- Make sure all units are level and plumb.
- For base cabinets, adjust feet flush to floor.
- Using clamps, pre-drill holes and gang units together with #8 x 1 3/8" screws.
- Secure to wall cleats.(mounting hardware not included)

Pull top of panel down to access inside of cabinet

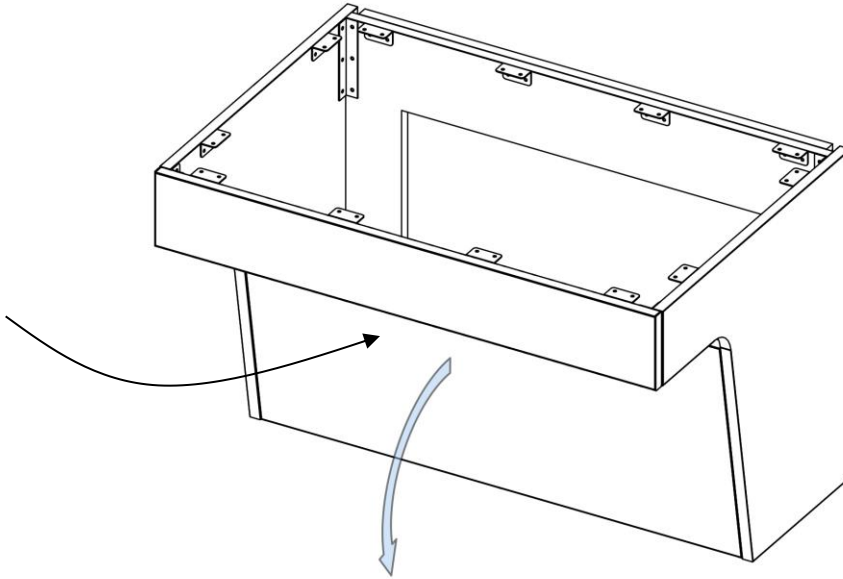

Screw thru overhead into wall cleat.
Or, secure to wall studs
where possible.
(Mounting hardware
not included)

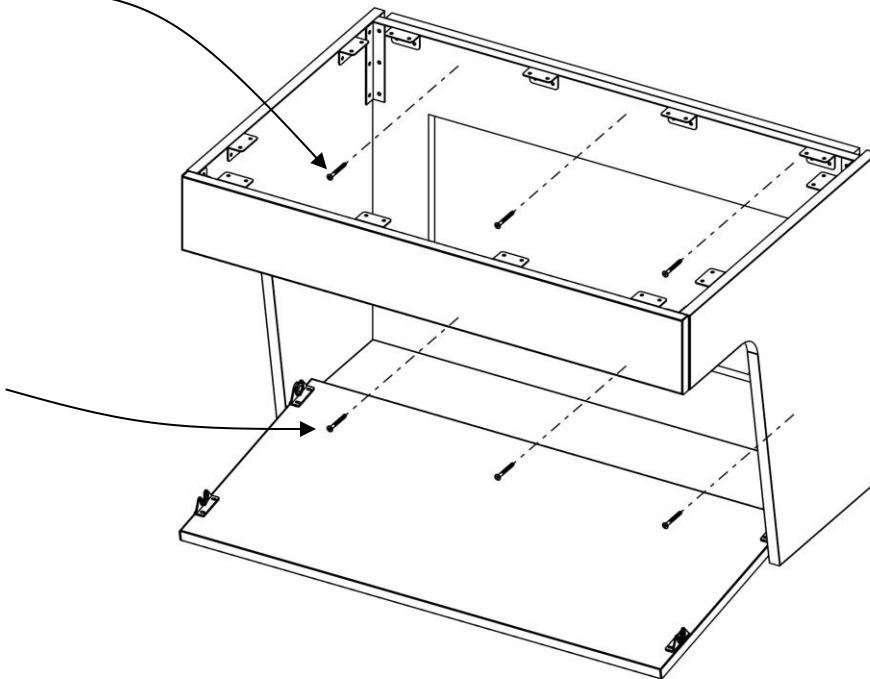

Screw thru overhead
cabinet strapping and
into wall studs/blocking.
(Mounting hardware
not included)

CaseWorks Installation Instructions

Step 11a (for installation of vertical soffits only):

- Make sure all installed wall cabinets are level and plumb prior to soffit installation.
- Assemble soffit using L-brackets and #8 x 3/4" screws.

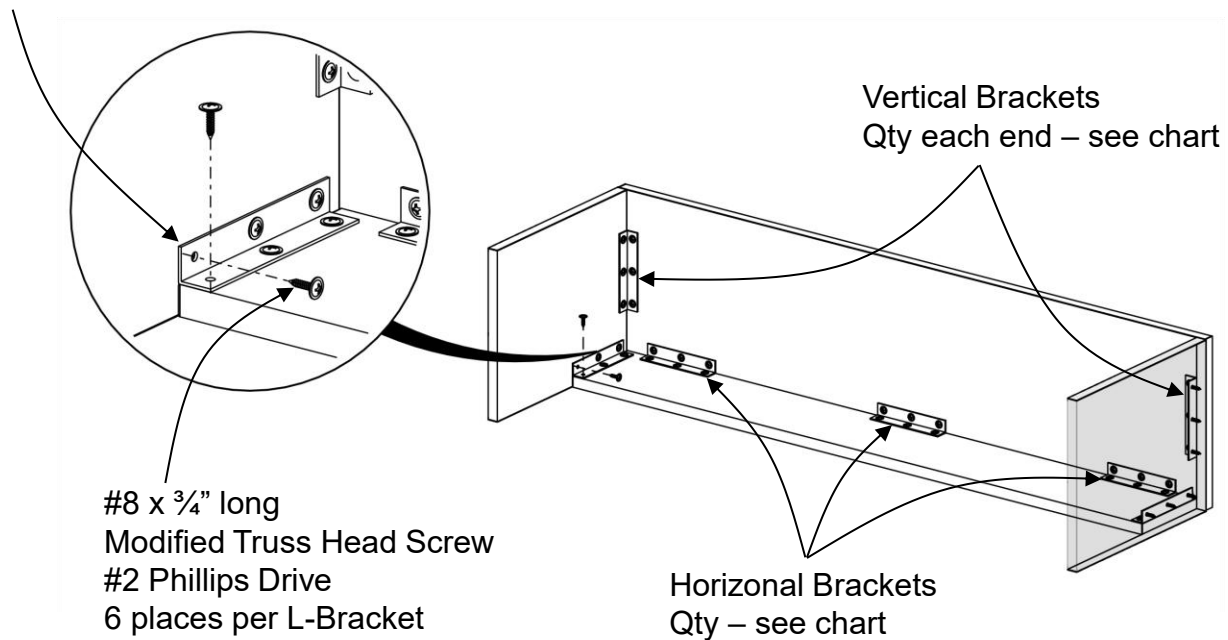
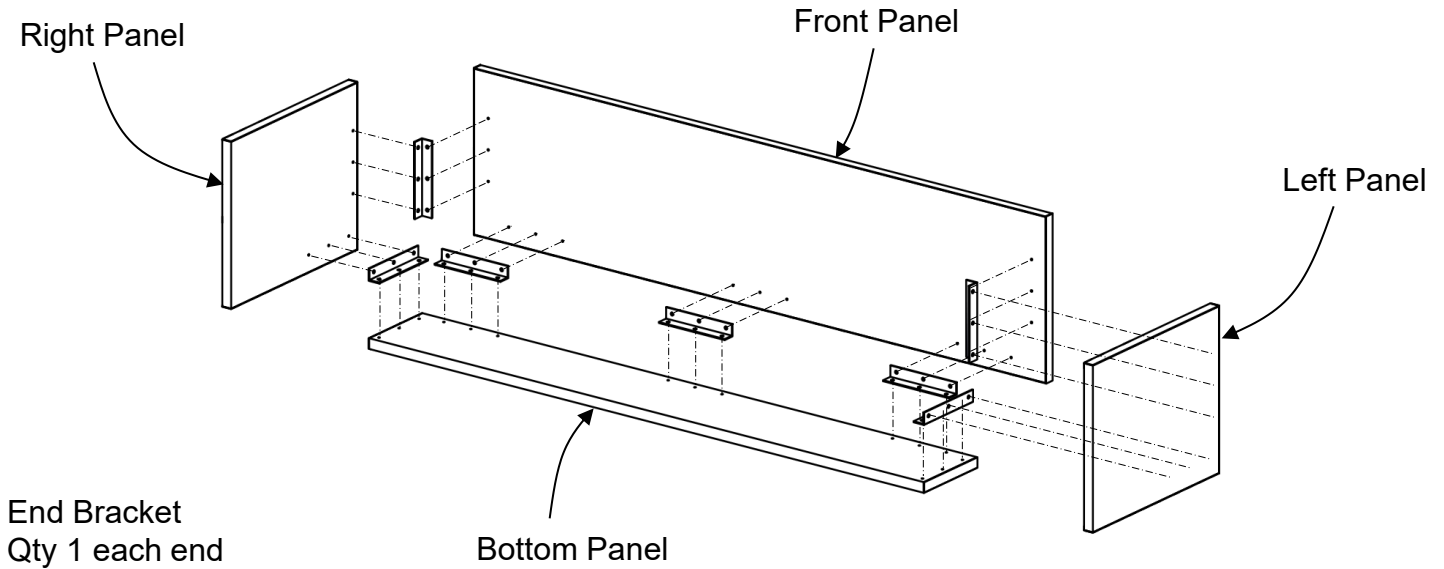

Vertical Bracket qty (each end)		
Soffit Height	L-Bracket	Qty
6h	RH-260-46-910-I	1
12h	OX-LB2-I	1
18h – 24h	OX-LB2-I	2
30h – 36h	OX-LB2-I	3

Horizontal Bracket qty		
Soffit Width	L-Bracket	Qty
12w – 18w	OX-LB2-I	1
19w – 34w	OX-LB2-I	2
35w – 50w	OX-LB2-I	3
51w – 66w	OX-LB2-I	4
67w – 82w	OX-LB2-I	5
83w – 96w	OX-LB2-I	6

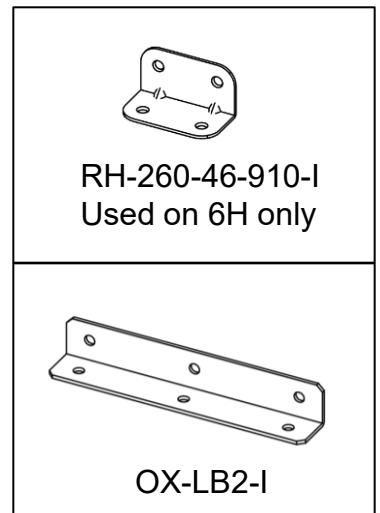

CaseWorks Installation Instructions

Step 11b (for installation of vertical soffits only):

- Make sure all installed wall cabinets are level and plumb prior to soffit installation.
- Align soffit on top of wall cabinets.
- Secure soffit to wall cabinets using #8 1 3/8" screws

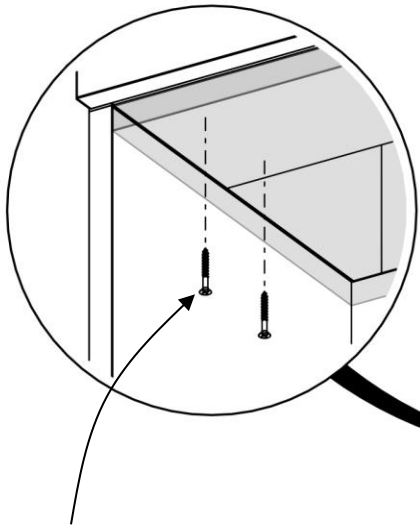

#8 x 1 3/8" long
Flat Head Screw
#2 Phillips Drive
See qty chart

Install 2 screws, every 6" - 8",
thru the top of wall cabinet up into
the bottom panel of the soffit

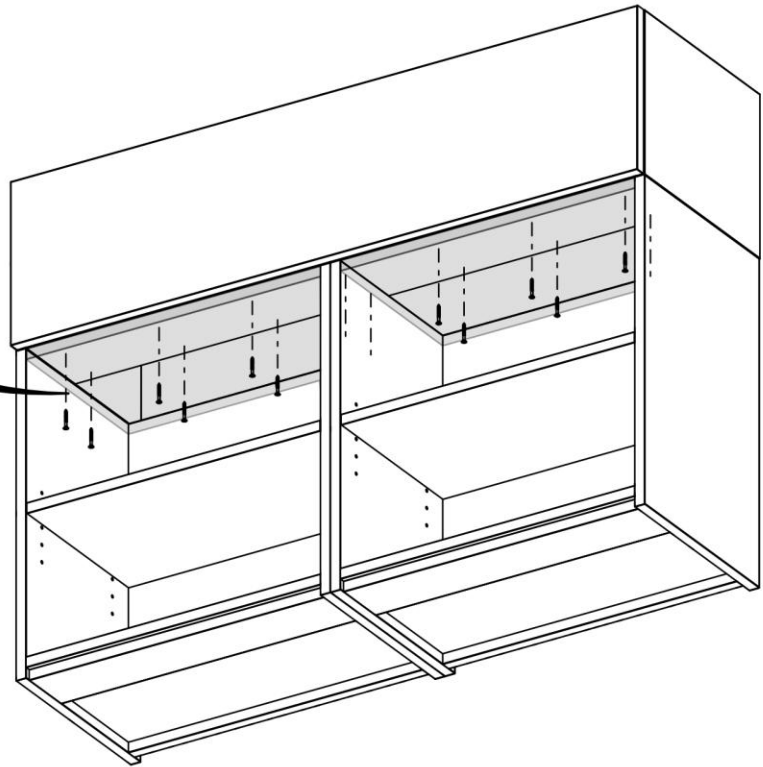

Soffit Width	Qty of Screws
12w – 15w	4
16w – 23w	6
24w – 31w	8
32w – 39w	10
40w – 47w	12
48w – 55w	14
56w – 63w	16
64w – 71w	18
72w – 79w	20
80w – 87w	22
88w – 96w	24

CaseWorks Installation Instructions

Step 12: Filler strips/End panels (if applicable): Install filler strips to side of cabinet in preferred method.

- Filler panels are shipped in 6" widths and may be field cut to achieve a proper fit.
- Filler panels should not be field cut less than 1" wide to allow for proper installation.
- Filler panels include mounting brackets. Quantity of brackets included according to size.

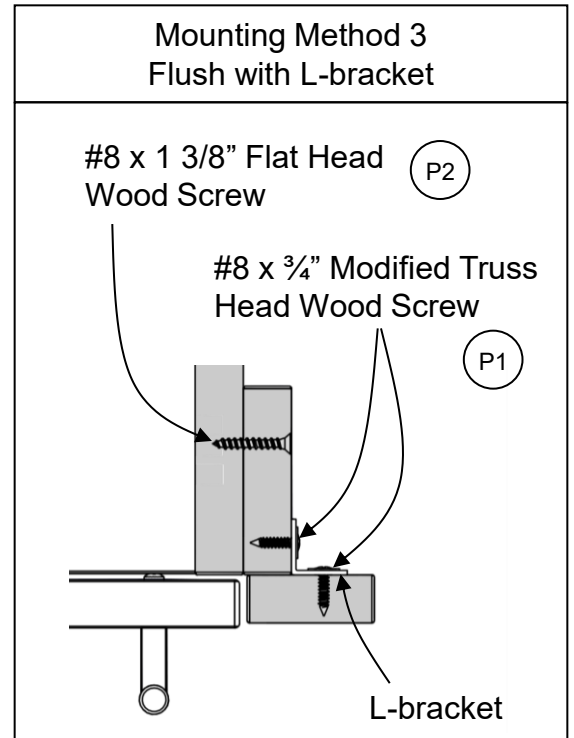
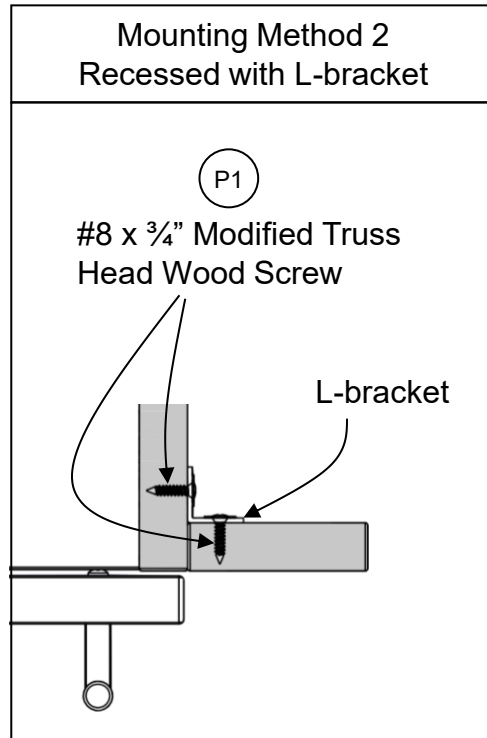
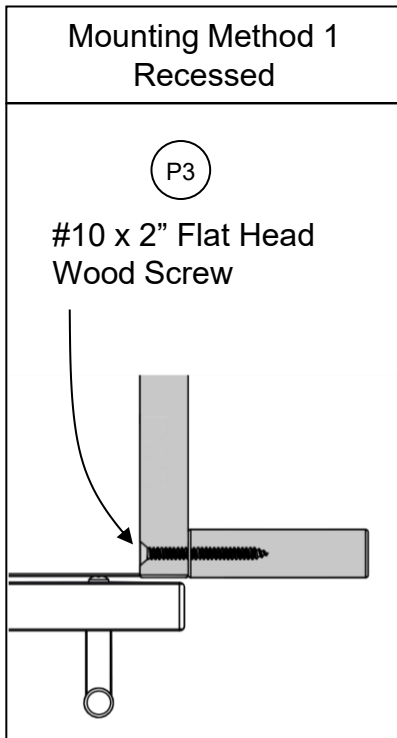
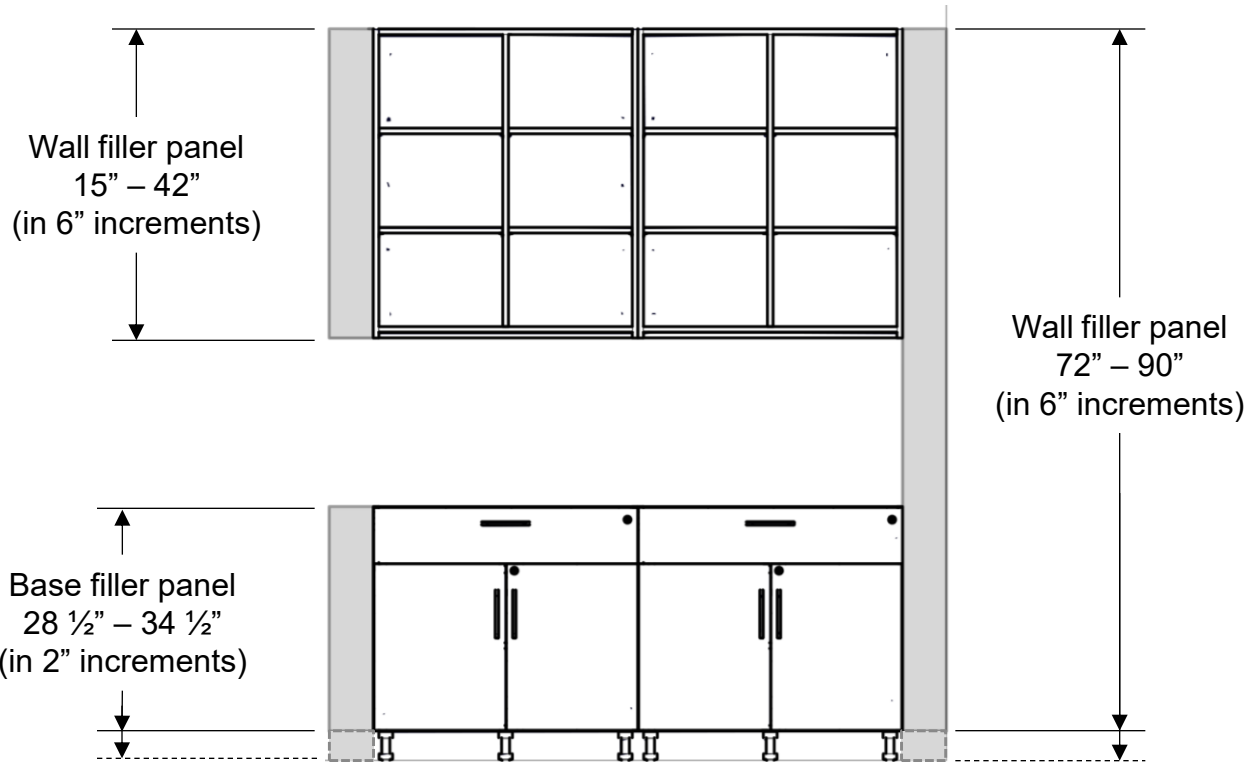

CaseWorks Installation Instructions

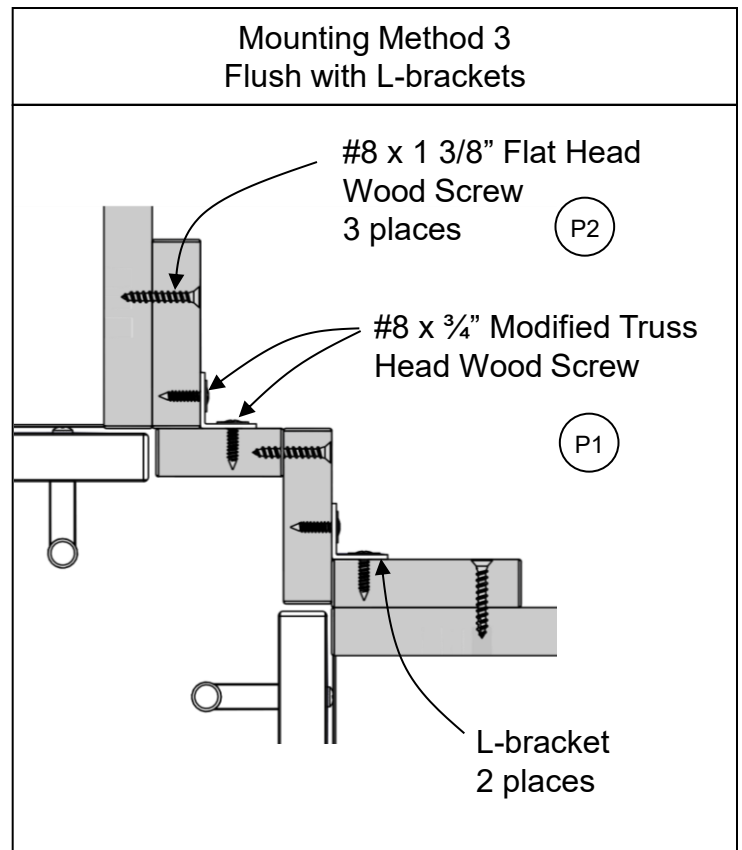
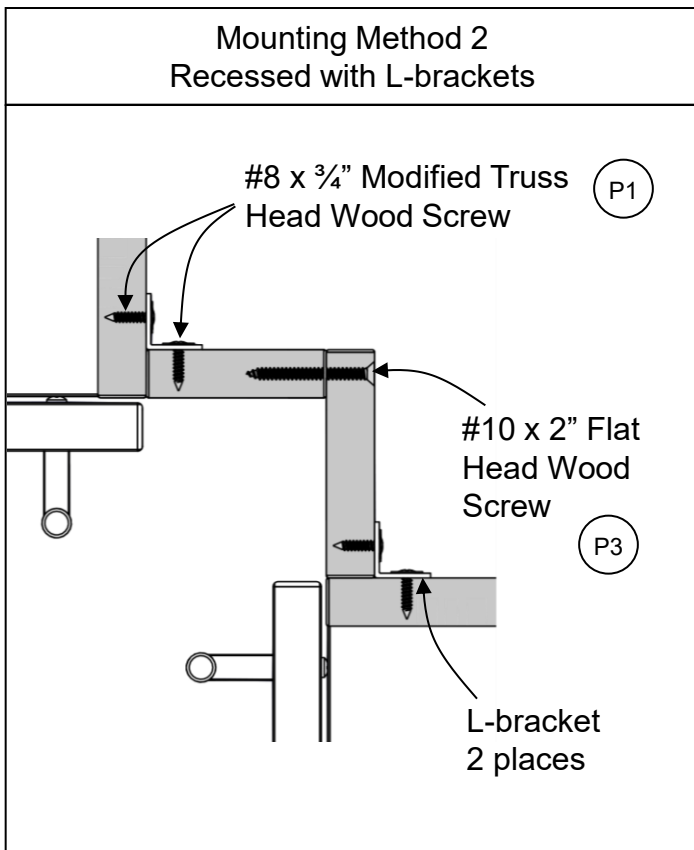
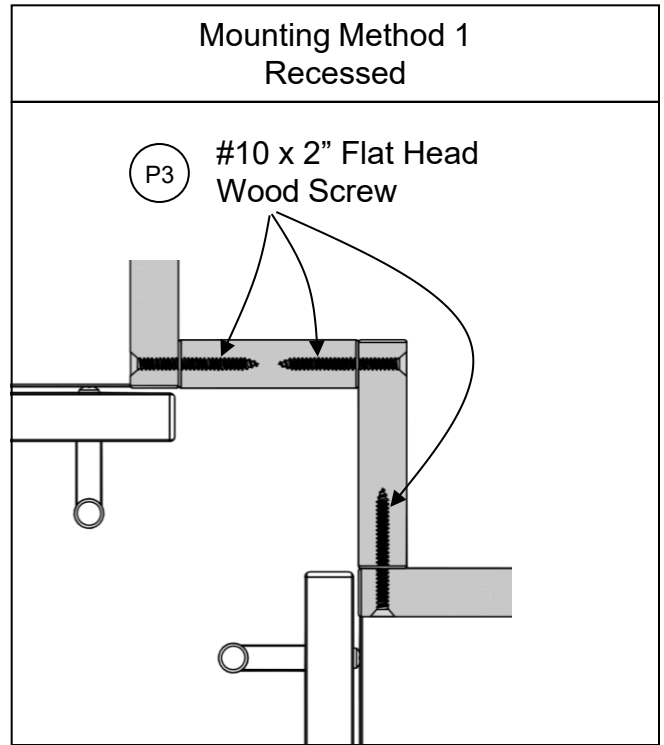
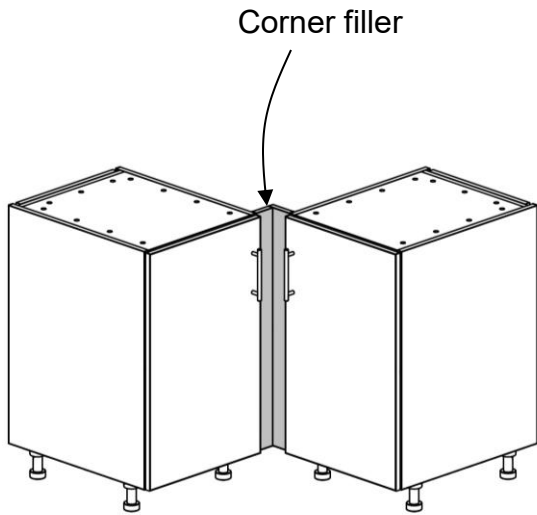

CaseWorks Installation Instructions

Step 13a: Install toe kick clip base to toe kick using #6 x 5/8" screw at each end.

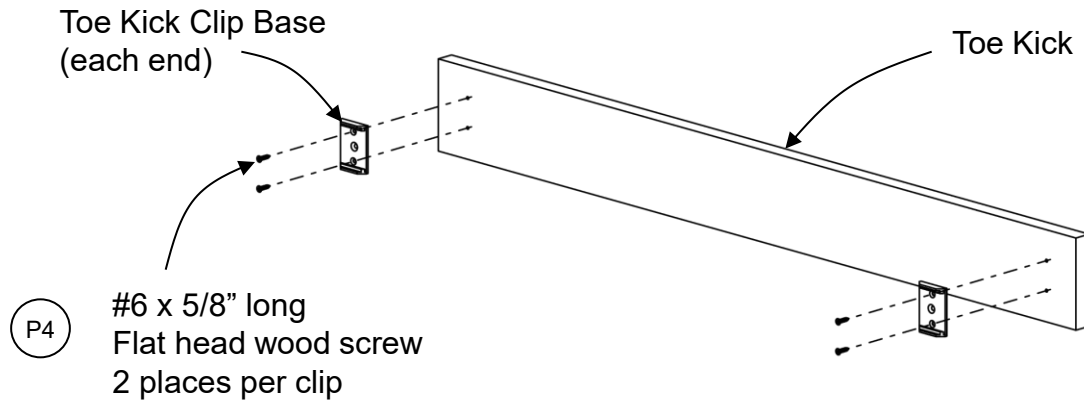

Step 13b: Install toe kick clips to toe kick clip base.

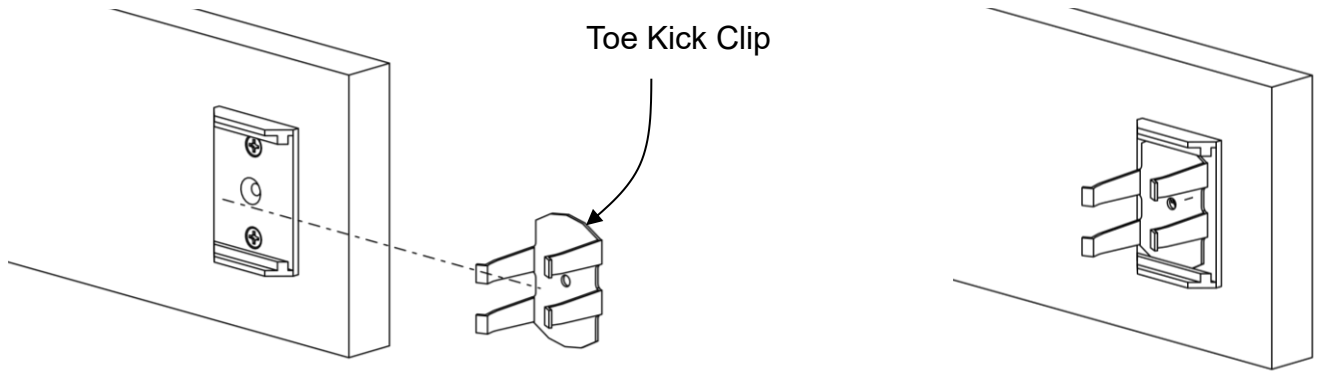

Step 13c: Apply double sided tape (not included) to center foot clips. If spanning multiple cabinets, attachment points should be approximately 30" apart with one connection per cabinet. A minimum of 3 clips is recommended.

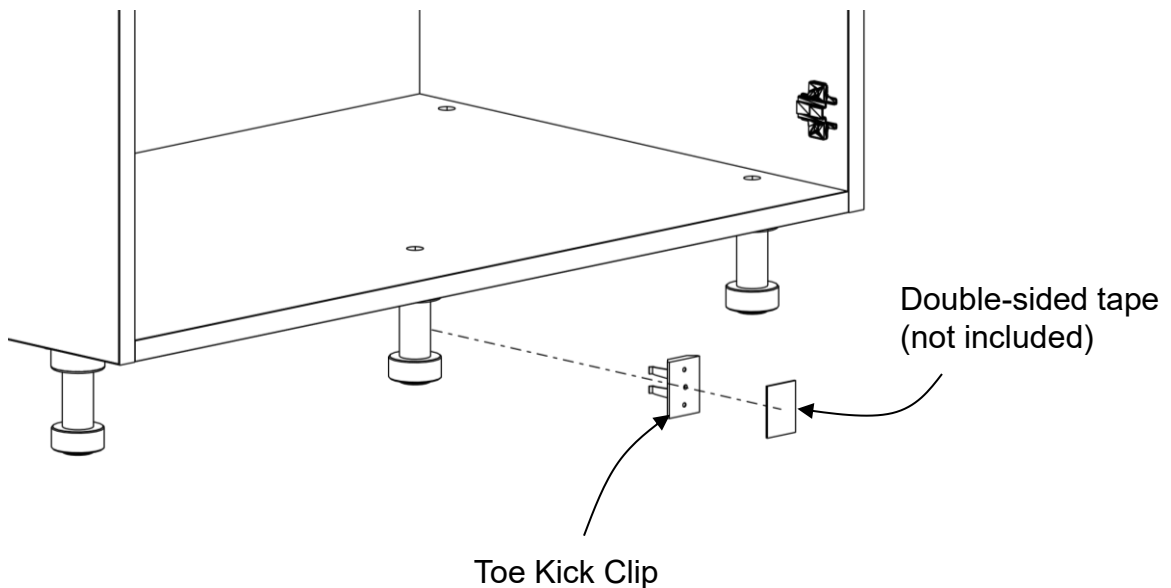

CaseWorks Installation Instructions

Step 13d: Install toe kick to legs, pressing firmly at each clip location.

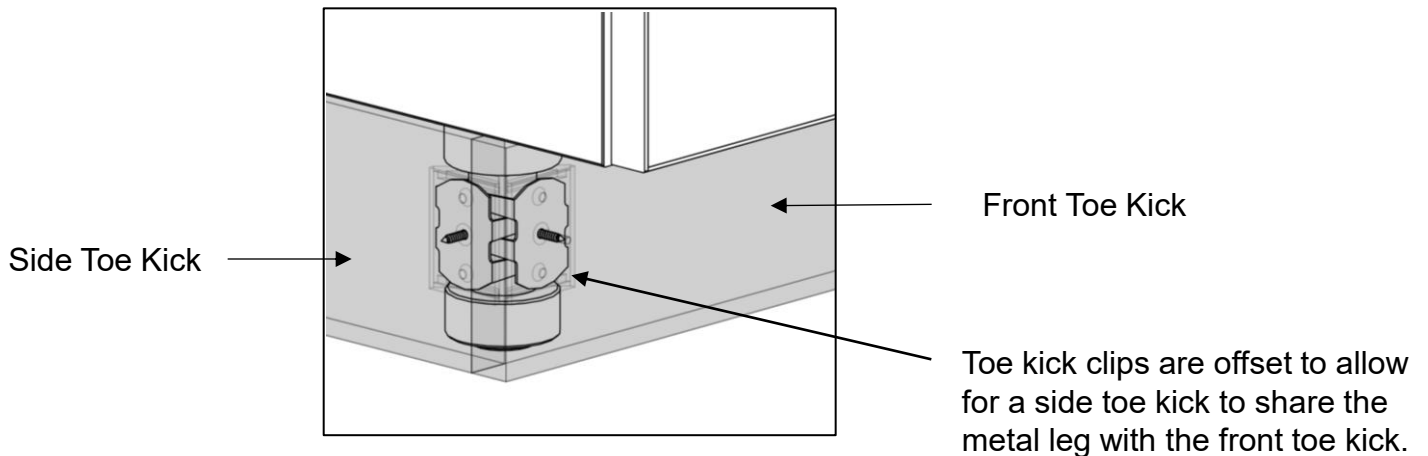
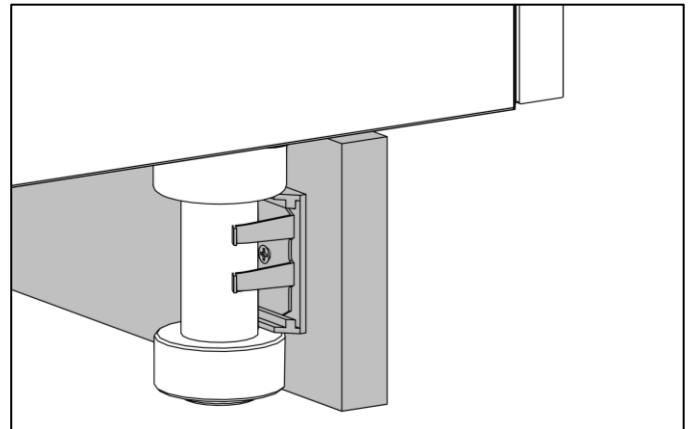
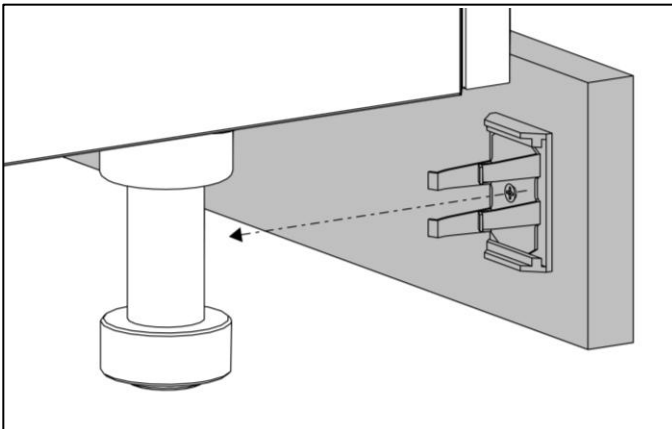
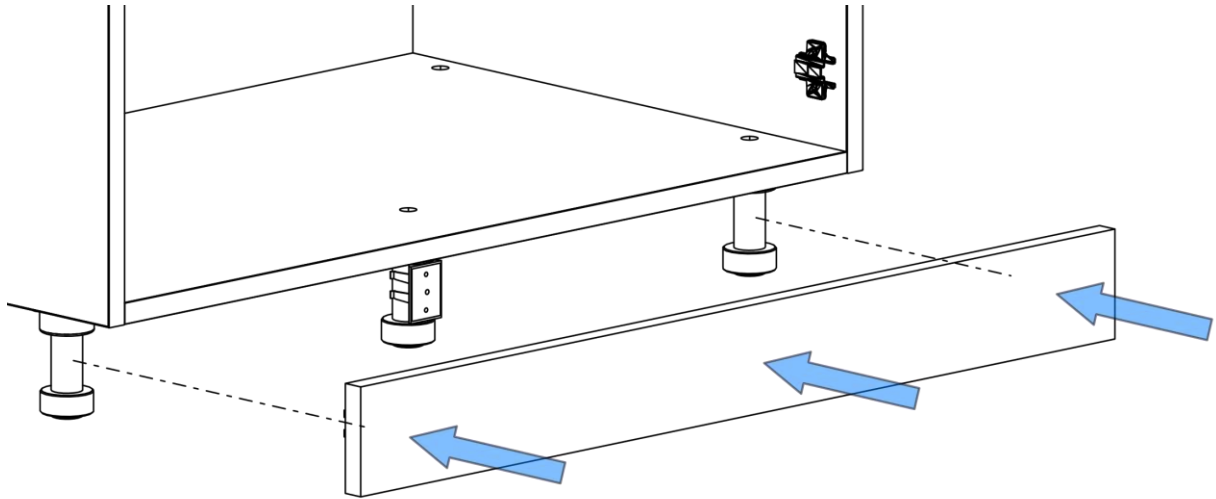

CaseWorks Installation Instructions

Step 14: Position and install worksurfaces

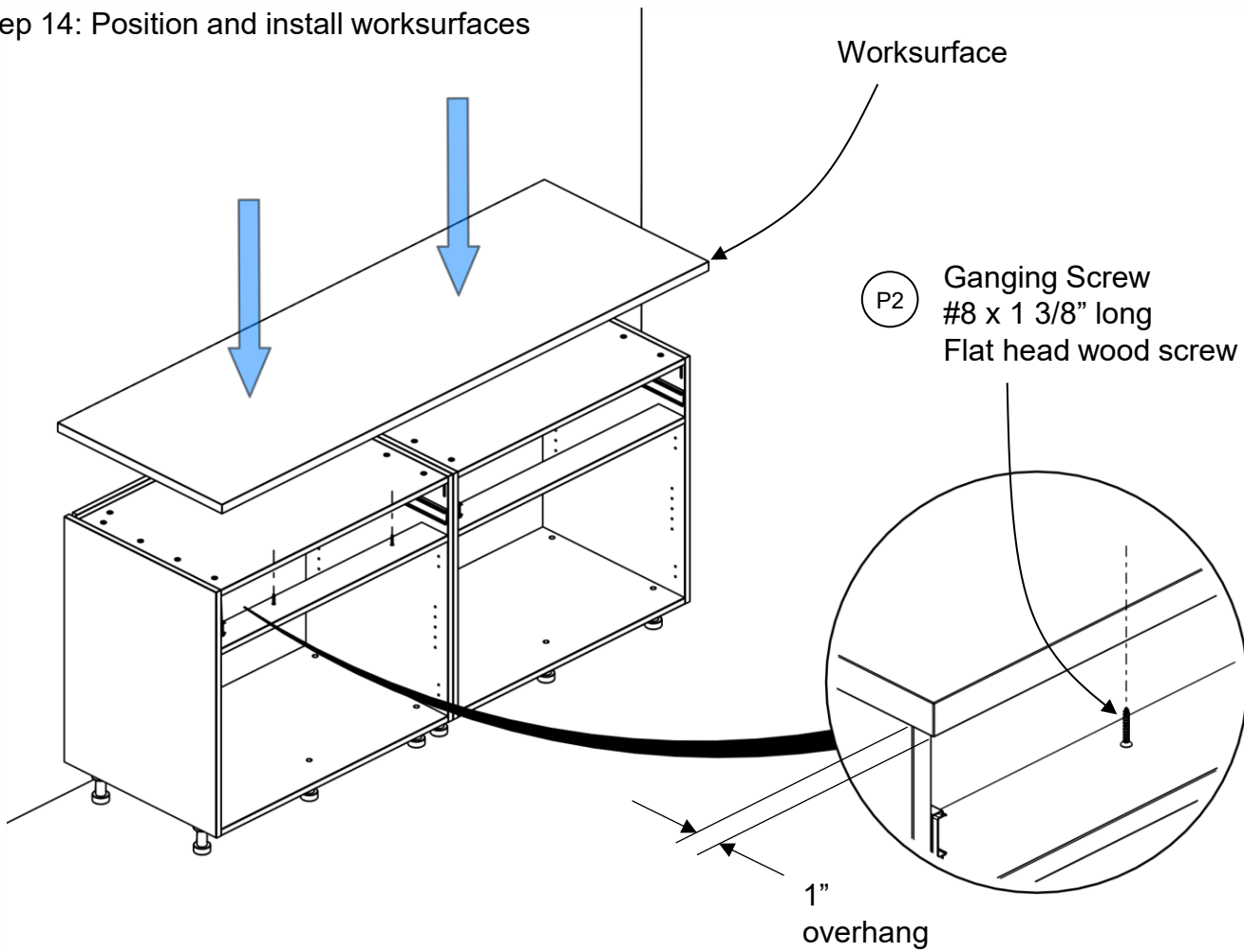

Step 15: Install backsplash using a general-purpose construction adhesive

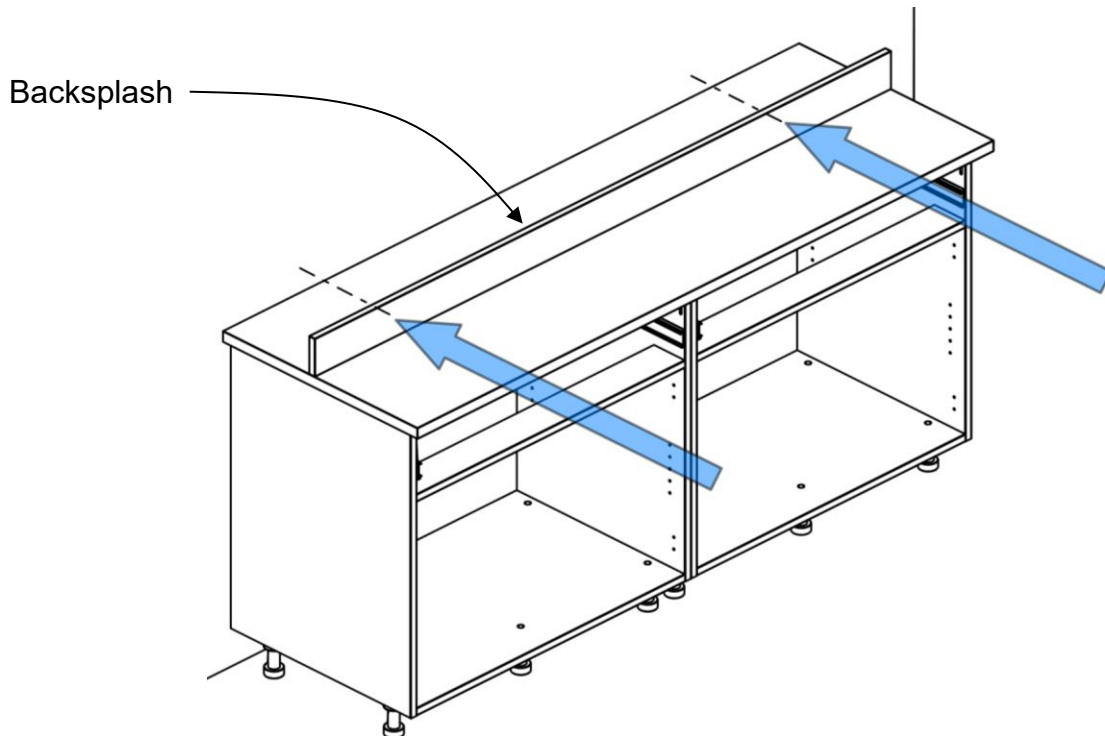

CaseWorks Installation Instructions

Step 16: Installing refrigerator surrounds.

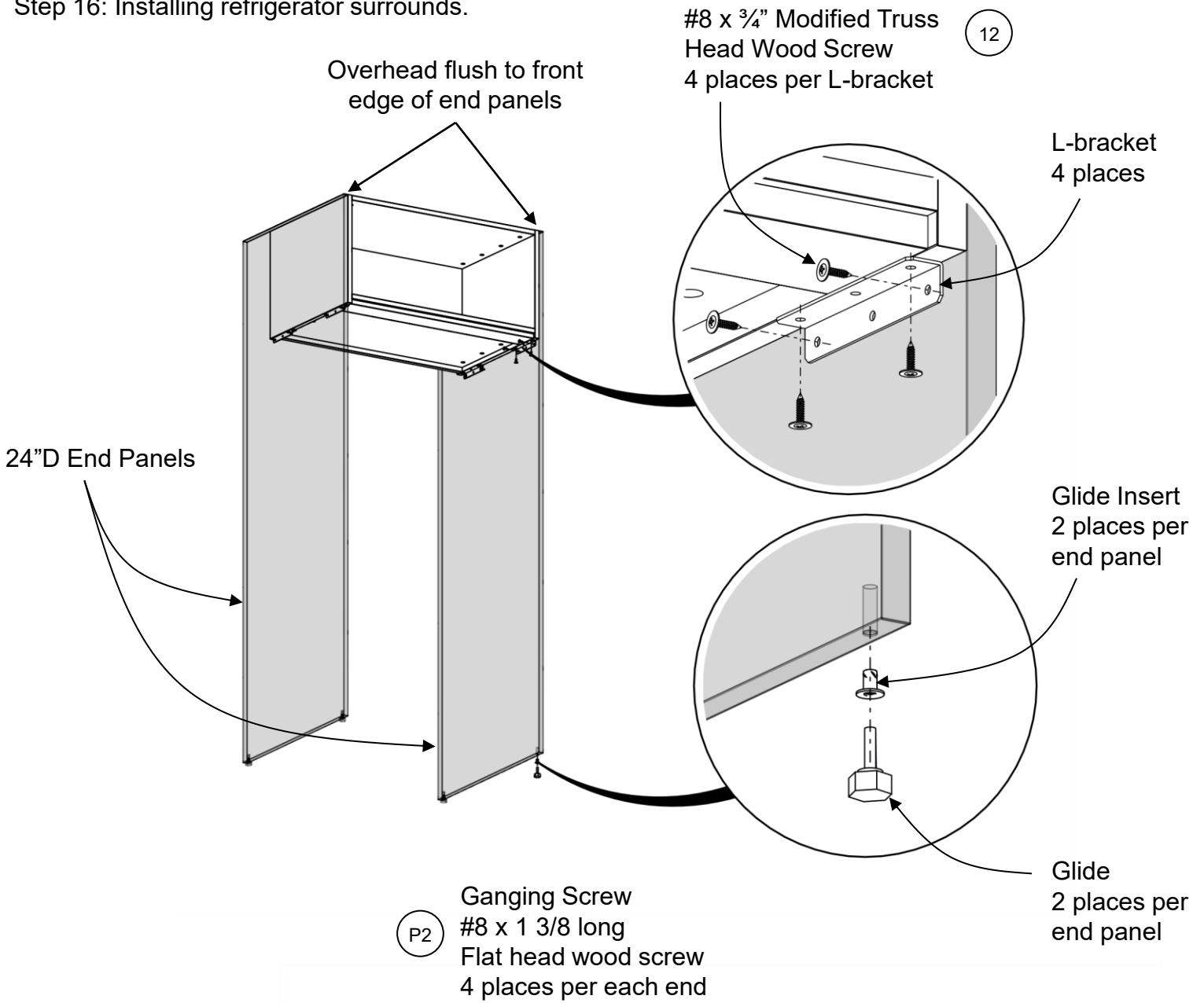

CaseWorks Installation Instructions

Step 17: Re-install all doors, drawers and shelves.

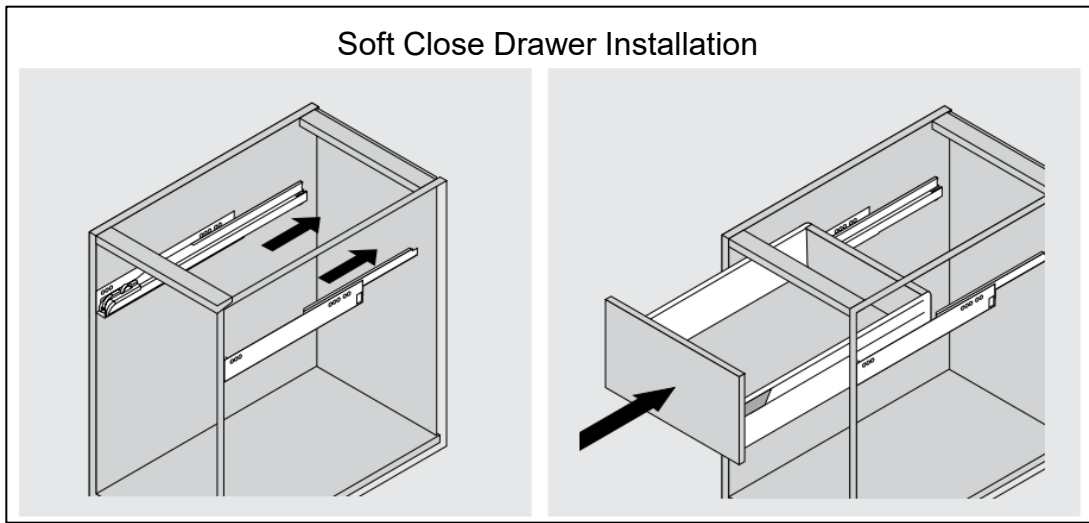
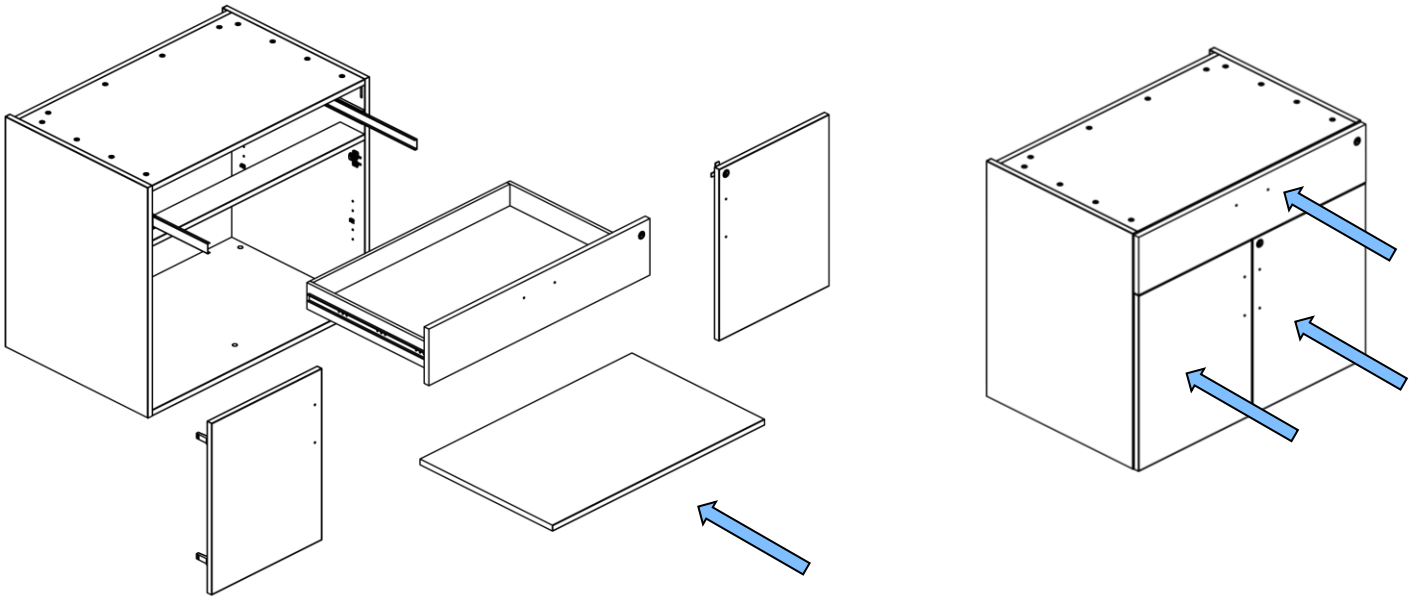

Step 18: Press foot plugs into foot adjustment holes and install any hardware as required.

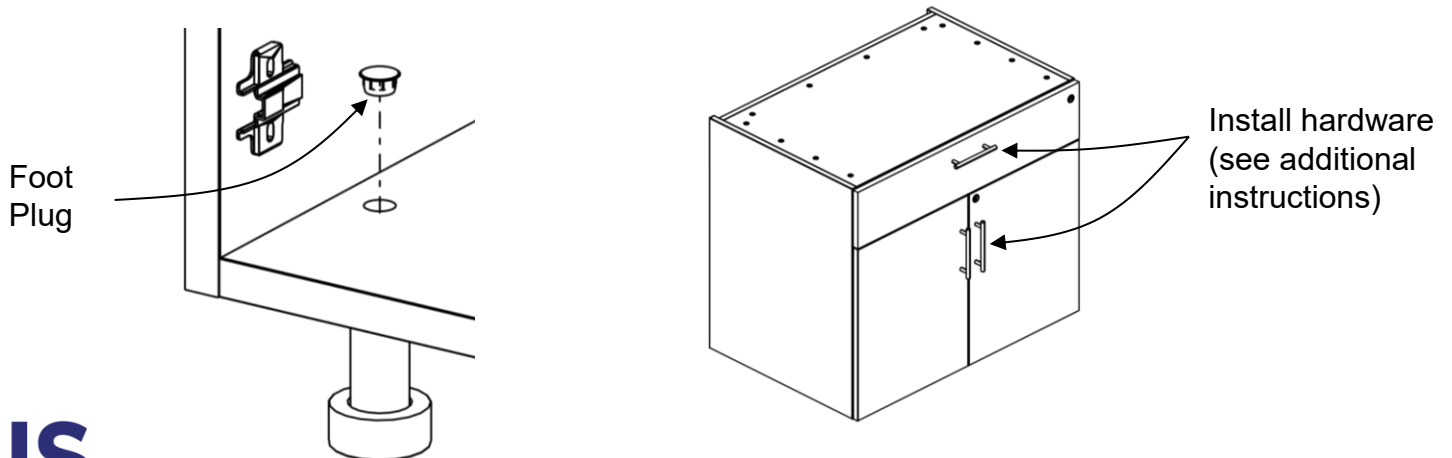

CaseWorks Installation Instructions

Step 19: Re-install all doors, drawers and shelves. If necessary, adjust the hinges to ensure doors are flush.

Soft close drawer adjustments

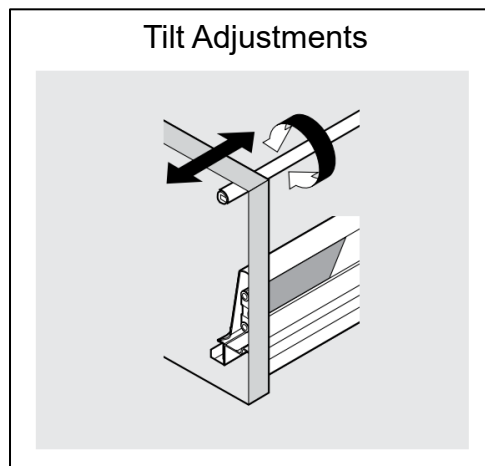
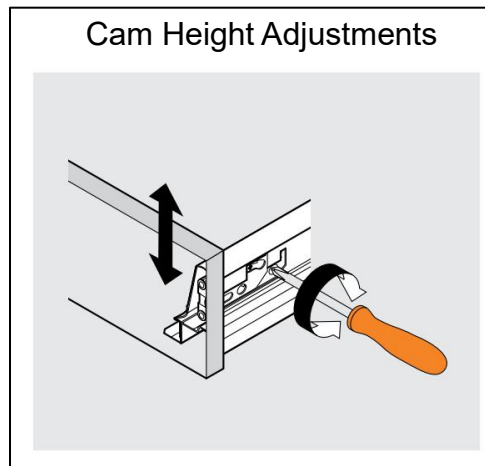
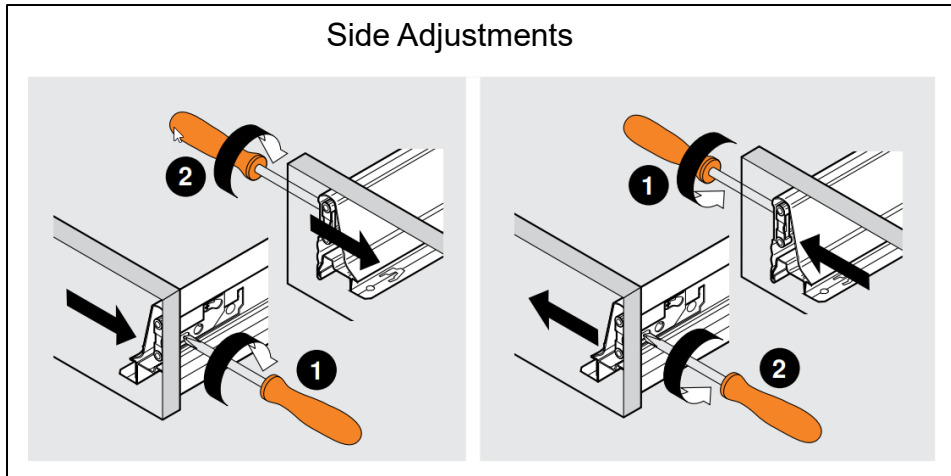

CaseWorks Installation Instructions

Step 20: Re-install all doors, drawers and shelves. If necessary, adjust the hinges to ensure doors are flush.

Horizontal Hinge Adjustment

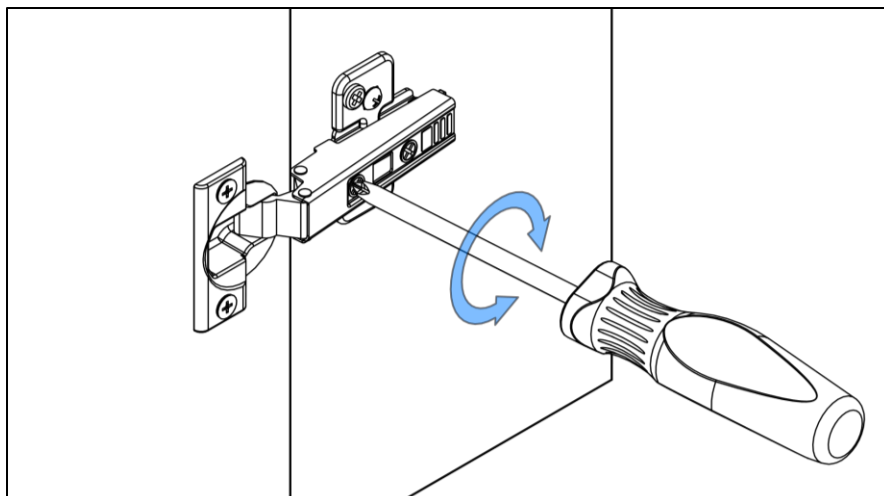

Vertical Hinge Adjustment

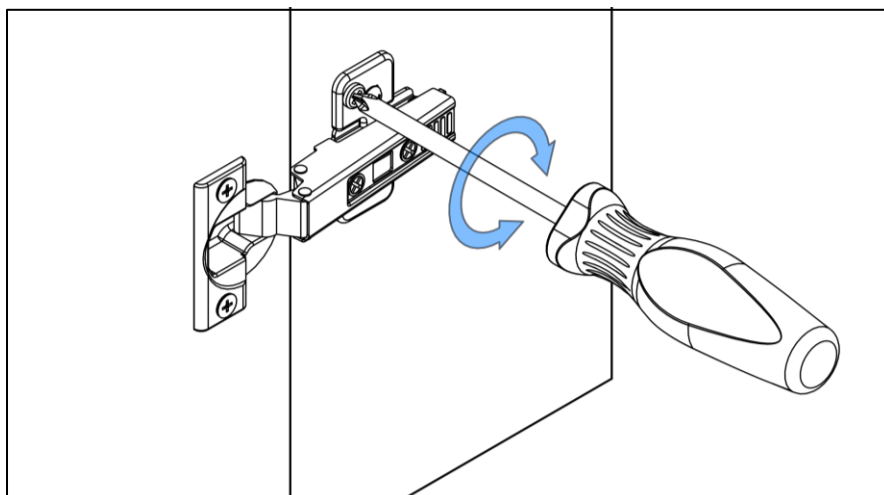

Hinge Depth Adjustment

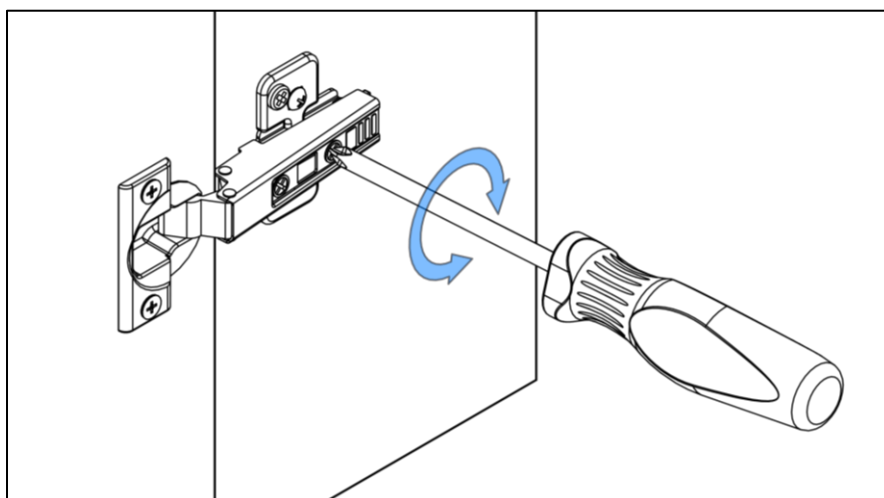

CaseWorks Installation Instructions

Step 21: If applicable, add hinge restrictor clips at corners or against a wall.

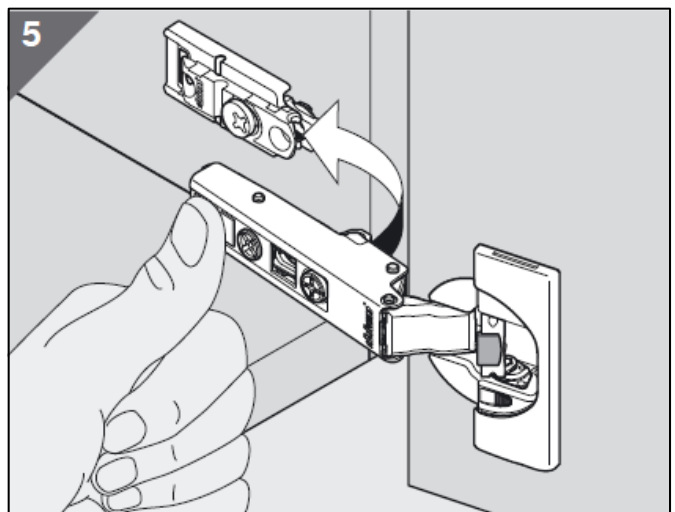
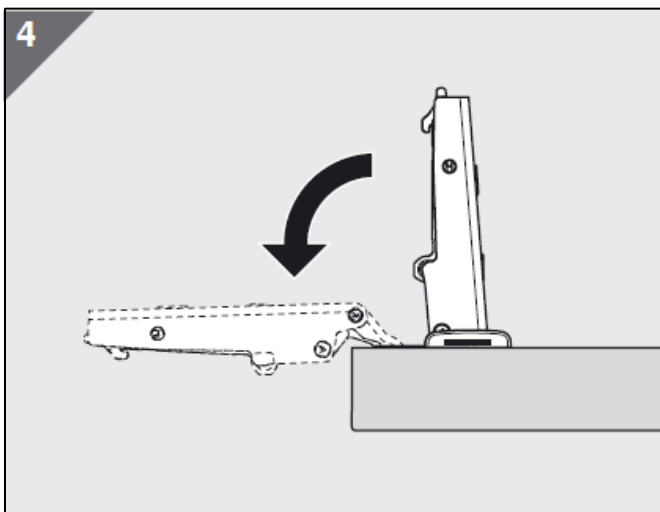
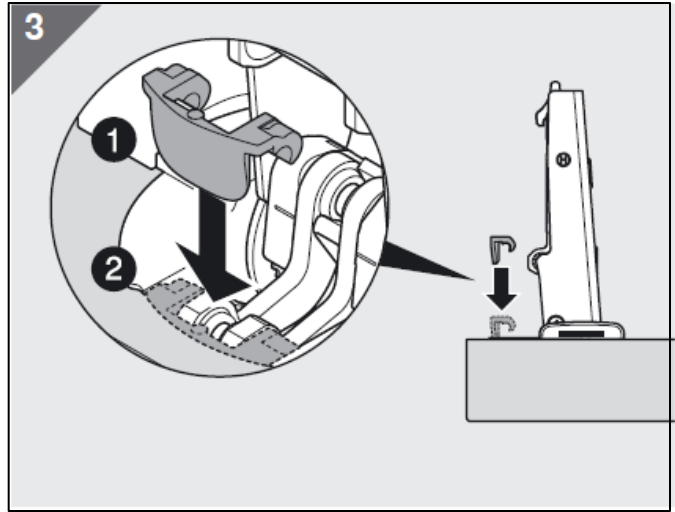
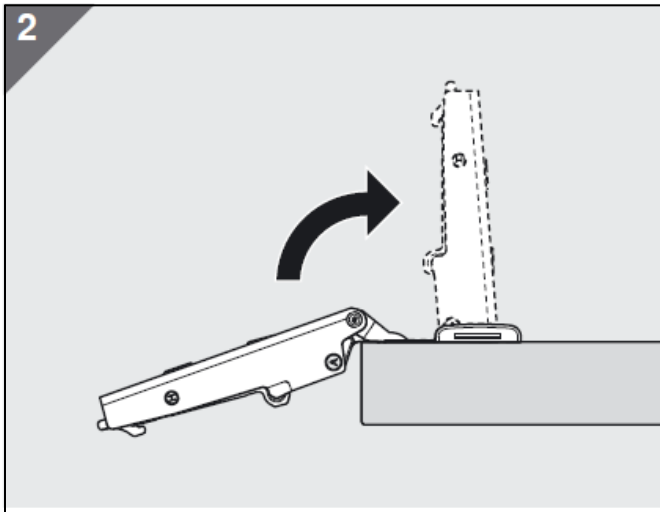
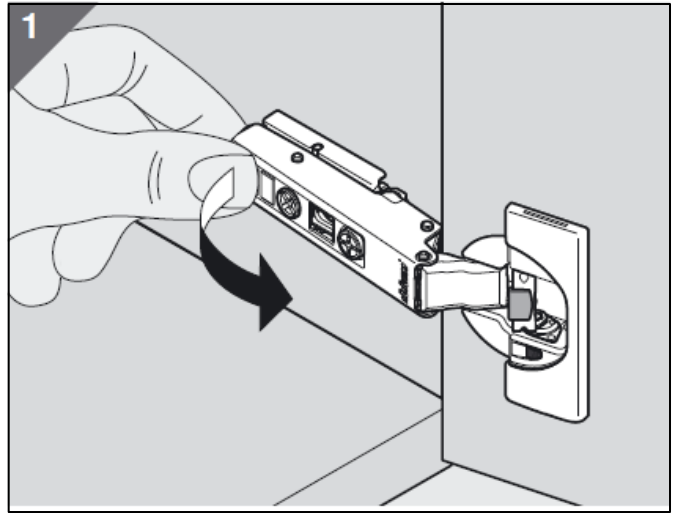
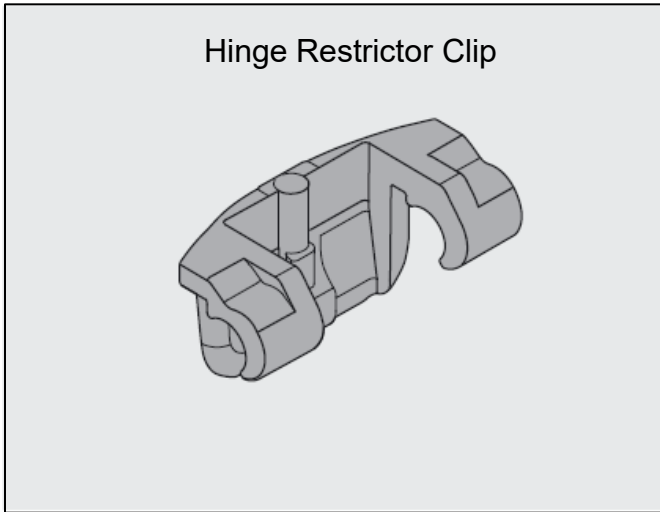

CaseWorks Installation Instructions

Step 22: If necessary, adjust the trash pullout door to ensure doors are flush.

Trash Pullout Door Adjustment

