









Date	Page No.	Description of change	Name
05/04/2021	1-6	Released	S. Powers
08/04/2021	2	Added leg part numbers	S. Powers
05/02/2025	1-6	Removed A02 & MWall components	P. Day

O-Leg Installation Instructions

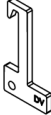
Parts List

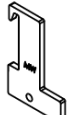
Item	Replacement Part number	Circle Sheet Part Number	Description	Image
P1	WFS-VSLB	RWFS-VSLB-A	Divi Hanger Frame Mounting Bracket	
	WFS-MXLBB	RWFS-MXLBB-A	Matrix Hanger Frame Mounting Bracket	
P2	RH-TSP1234B-I	RH-TSP1234B	#12 x 3/4" long Pan Head Drilling Screw	
P3	WFS-HMOLBR	RWFS-HMOLBR	AO2 Locking Bracket Left / Right	
	WFS-DVOLB	RWFS-DVOLB	Divi Locking Bracket	
	WFS-MXOLB	RWFS-MXOLB	Matrix Locking Bracket	
	WFS-MWOLB	RWFS-MWOLB	Mwall Locking Bracket	
P4	RH-QS0978	RH-QS0978	#9 X 7/8" long Flat Head Wood Screw	

O-Leg Installation Instructions

Parts List

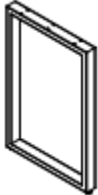
Item	Replacement Part number	Circle Sheet Part Number	Description	Image
P5	RC-SOL2712PM	RC-SOL2712PM	O-Leg 27H x 12W	
	RC-SOL2718PM	RC-SOL2718PM	O-Leg 27H x 18W	
	RC-SOL2724PM	RC-SOL2724PM	O-Leg 27H x 24W	
	RC-SOL2730PM	RC-SOL2730PM	O-Leg 27H x 30W	
	RC-SOL2736PM	RC-SOL2736PM	O-Leg 27H x 36W	

O-Leg Installation Instructions

Step 1:

Attach the hanger frame mounting bracket to the O-leg.

Note: Divi shown as an example, but all systems have similar panel attachment brackets.

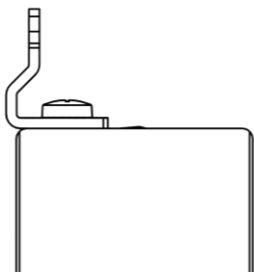
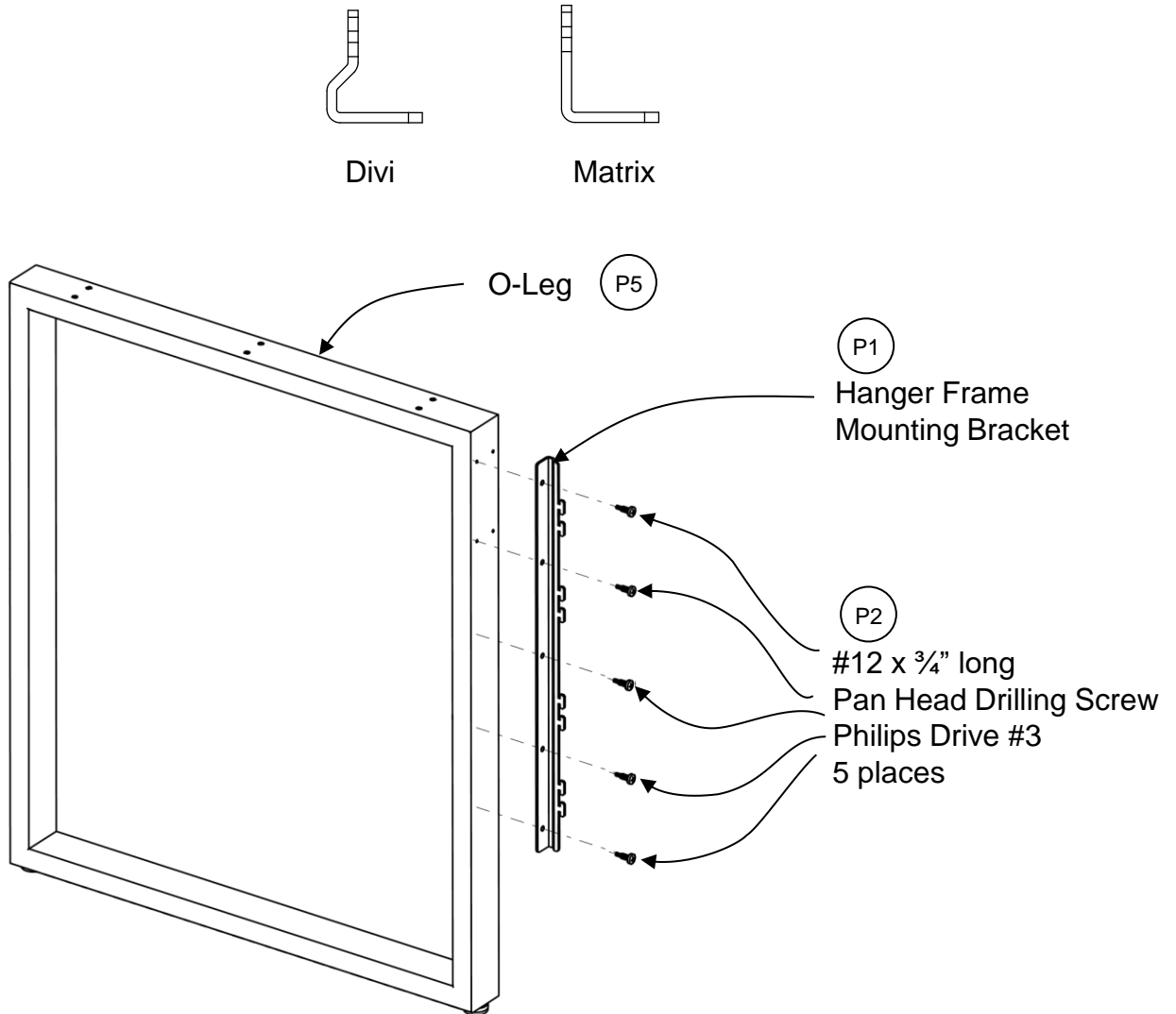

Left End

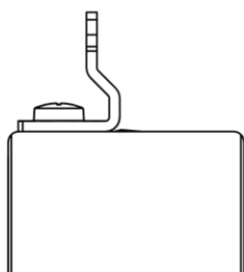

Shared Left

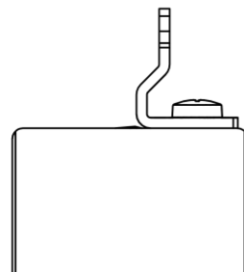

Shared Right

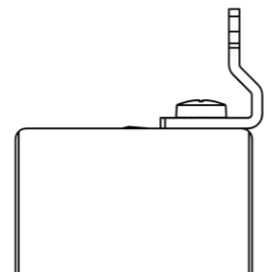

Right End

O-Leg Installation Instructions

Step 2:

Position the O-leg assembly into the slots on the hanger frame.

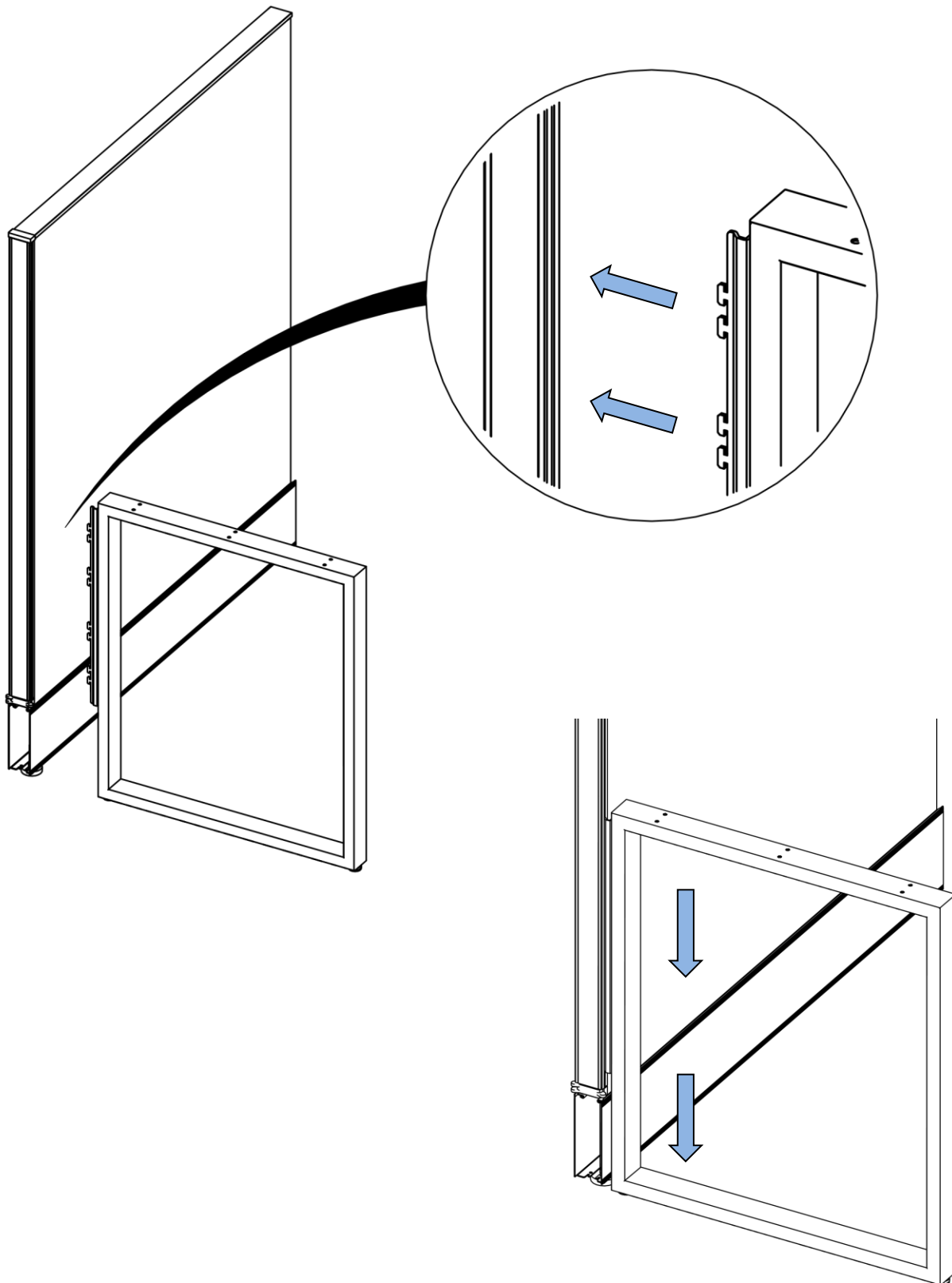

O-Leg Installation Instructions

Step 3:

Install the locking bracket into the hanger frame slots to secure the O-leg in place.

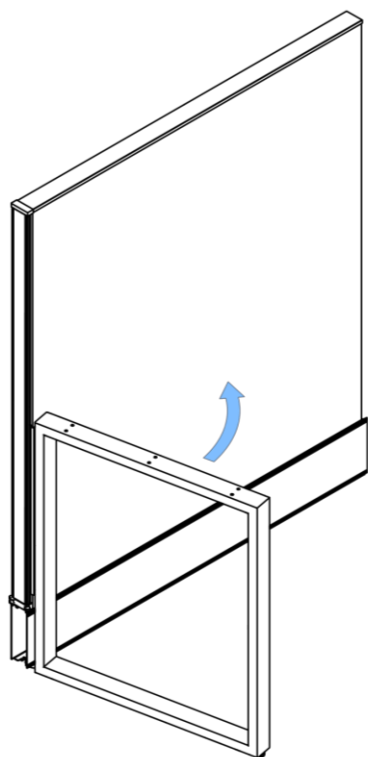

3a: Rotate the O-leg assembly to access the slots in the hanger frame

P3
Locking Bracket

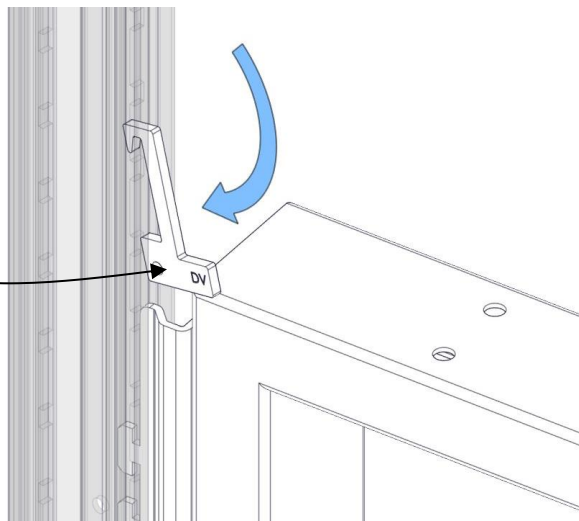

3b: Hook the Locking Clip into the hanger frame slot and rotate down.

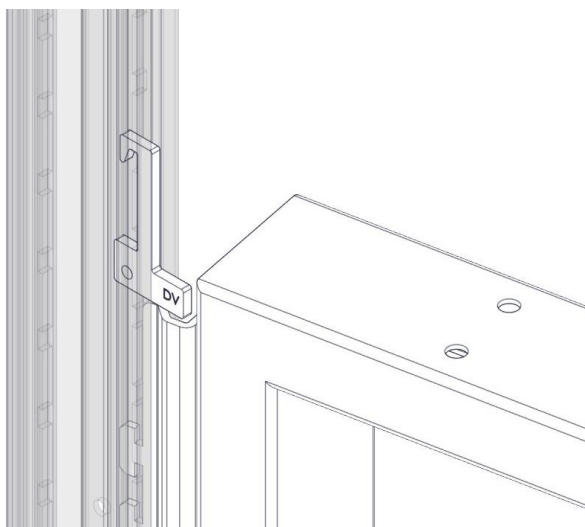

3c: Make sure the locking clip is properly seated as shown and the O-leg is secured to hanger frame.

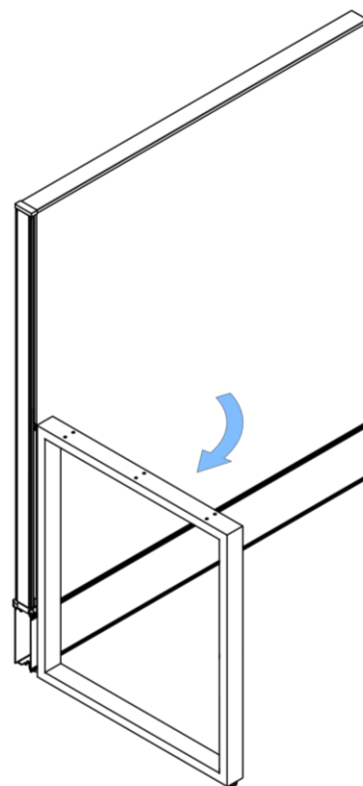

3d: Reposition the O-leg

O-Leg Installation Instructions

Step 4:

Secure the worksurface to the O-leg assembly.

