

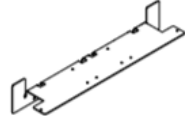





5 Drawer Lateral Flipper Door 2023

Date	Page No.	Description of change	Name
10.05.2023	1-10	Released	S. Powers
10.11.2023	2	Item P9, circle sheet p/n changed to -P	P. Fortin
11.09.2023	2,5	Replace RH-93406A193-I with RH-SFPP638EX	P. Fortin

5 Drawer Lateral Flipper Door 2023

Item	Replacement Part number	Circle Sheet Part Number	Description	Image
P1	S-LAT5DTFB	RS-LAT5DTFB-P	Slide Mounting Bracket	
P2	RS-FDSUR-A	RS-FDSUR-A	Glide Rail	
P3	RH-90056A143-I	RH-90056A143	#6 x 3/16" Round Head Screw	
P4	RS-FDLRUBBUMP-I	RS-FDLRUBBUMP-I	Bumper	
P5	RH-90087A194-I	RH-90087A194	#8-32 x 1/2" Pan Head Thread Cutting Screw	
P6	RH-SFPP638EX	RH-SFPP638EX	#6 x 3/8" Serrated Flange Head Sheet Metal Screw	
P7	TSP838-A	TSP838-A	#8 x 3/8" Pan Head Drilling Screw	
P8	RP-MXHS83214A	RP-MXHS83214A	#8-32 x 5/16" Pan Head Thread Rolling Screw	
P9	S-LAT5DTFP30 S-LAT5DTFP36 S-LAT5DTFP42	RS-LAT5DTFP30-P RS-LAT5DTFP36-P RS-LAT5DTFP42-P	Flipper Door	

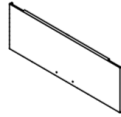
5 Drawer Lateral Flipper Door 2023

Step 1: Make a left-hand and a right-hand slide assembly. Secure glide rails to slide mounting brackets using #6 x 3/16" screws in 8 places as shown.

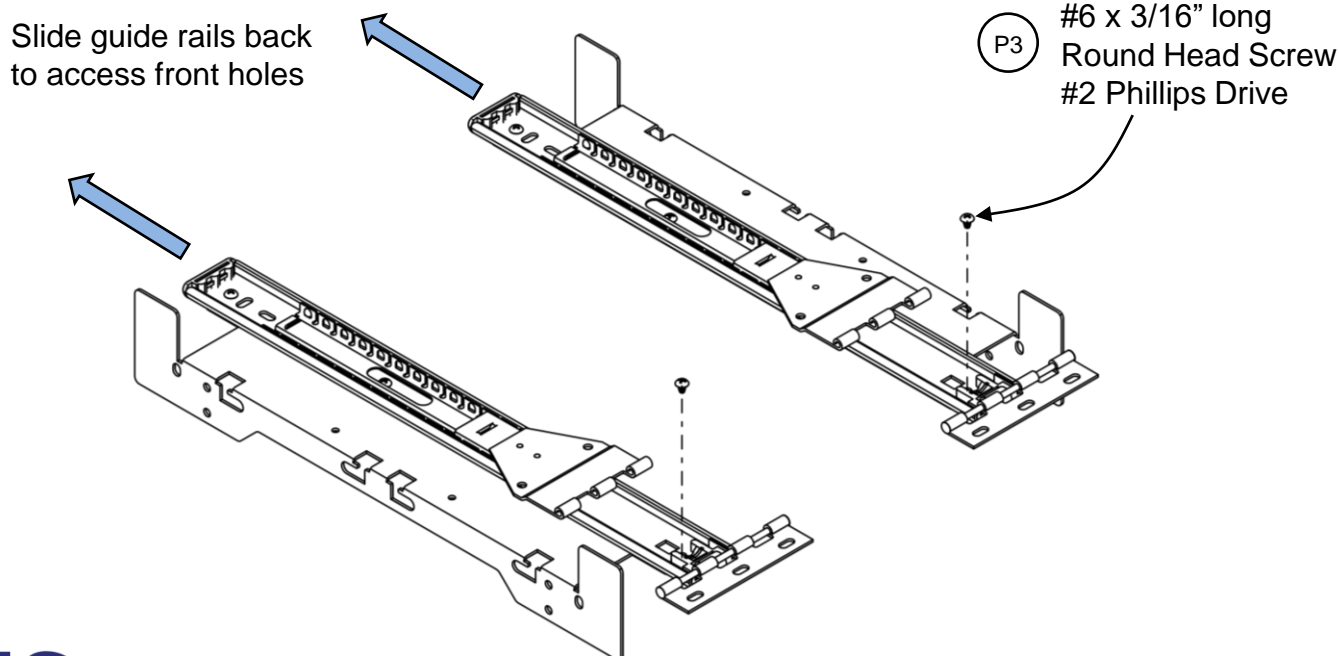
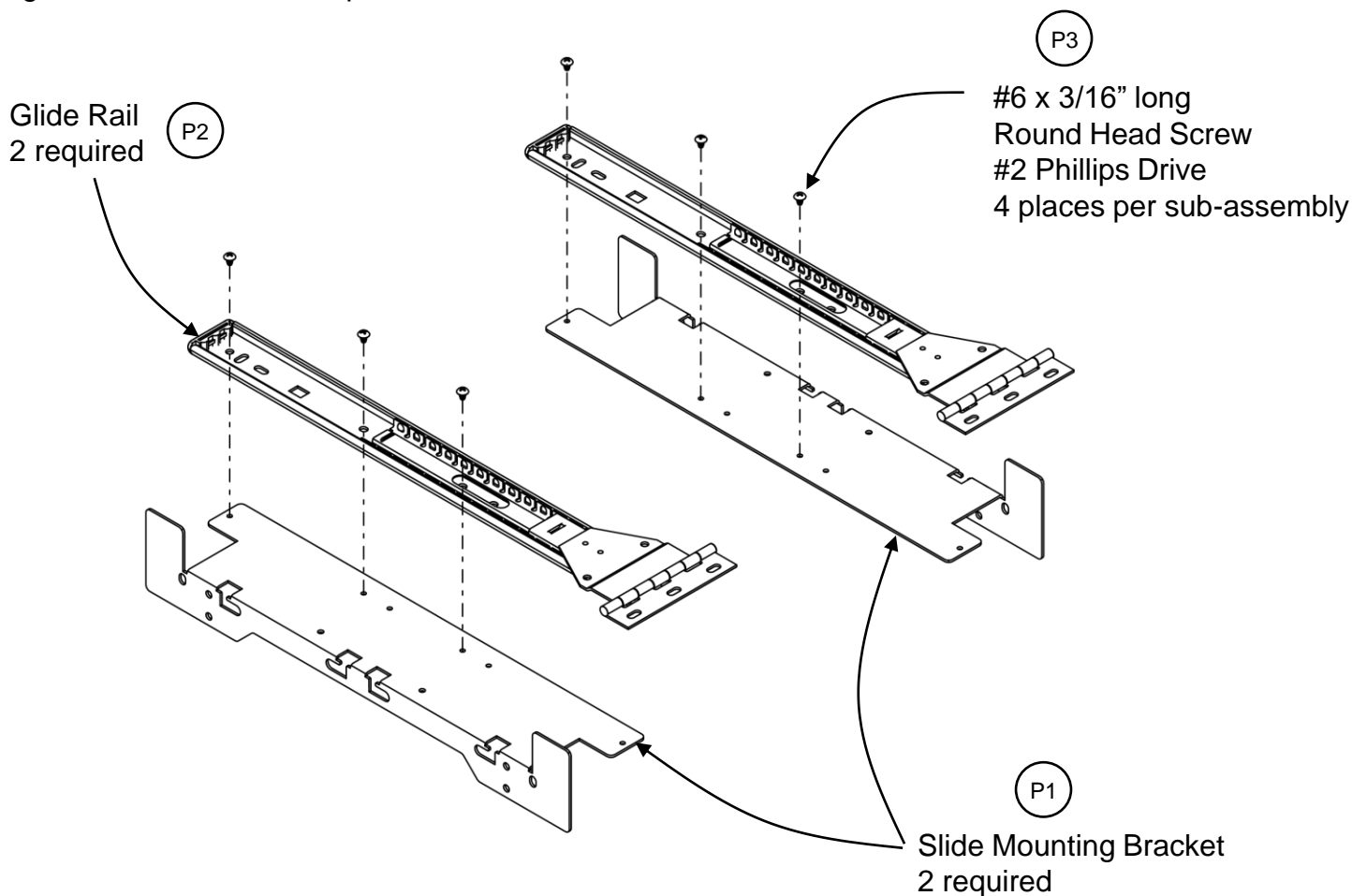

5 Drawer Lateral Flipper Door 2023

Step 2: Install a bumper to each sub-assembly using a #8-32 x 1/2" long pan head screw as shown.

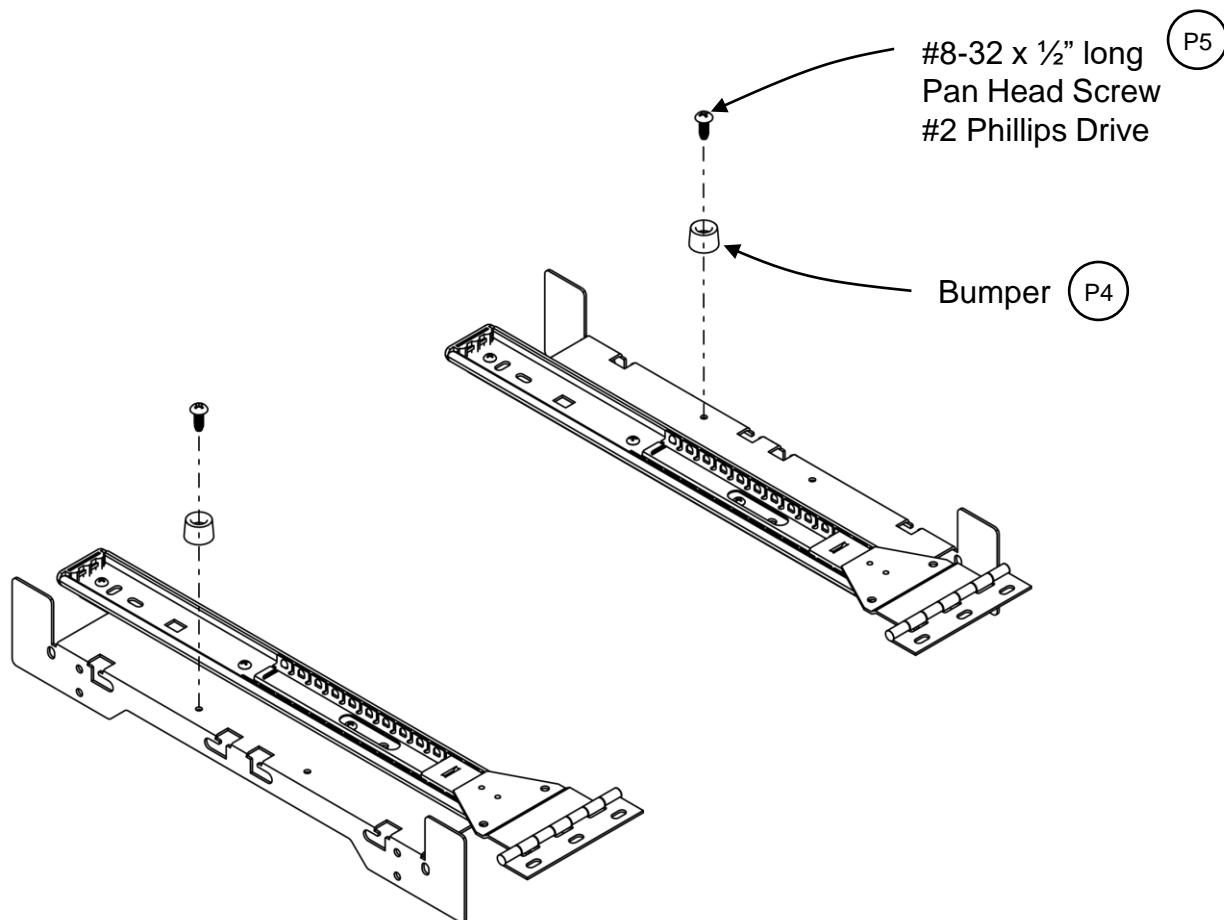

Step 3: Remove drawer from lateral storage.

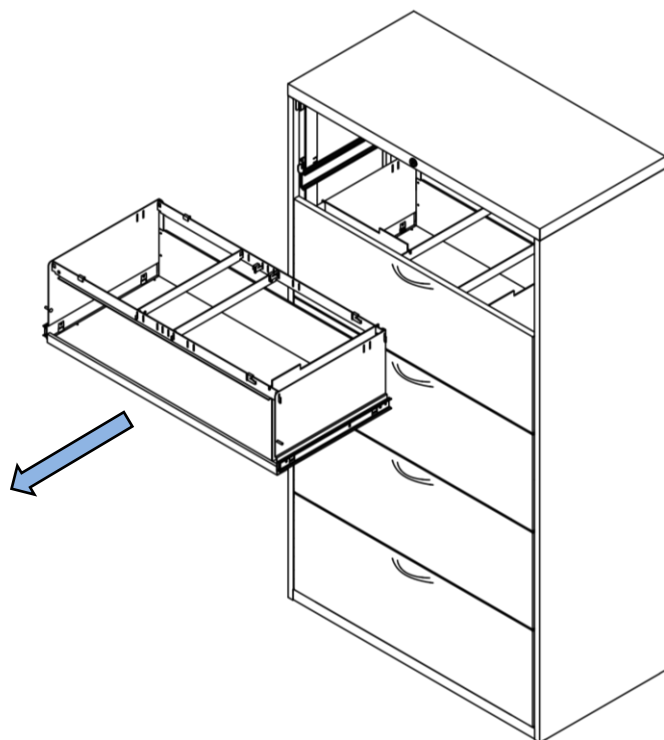

5 Drawer Lateral Flipper Door 2023

Step 4: Loosely install #8 x 3/18" truss head screws in 4 places

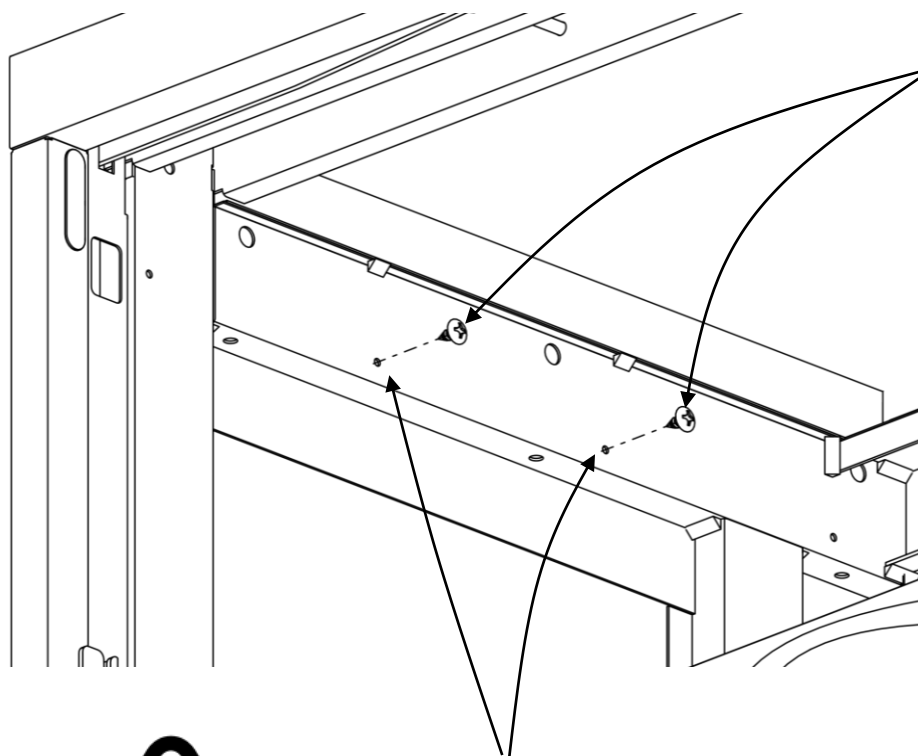

P6

#6 x 3/8" Serrated Flange Head Sheet Metal Screw
2 places each side of lateral



Note: Install screws loose, leaving approximately 1/8" space between the screw head and the side bracket.

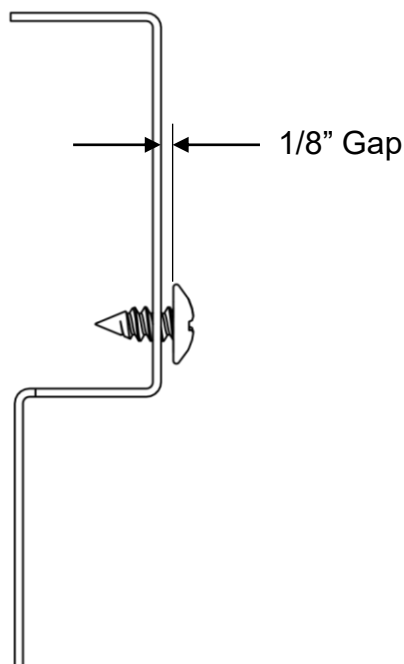

5 Drawer Lateral Flipper Door 2023

Step 5: Hang slide assemblies onto loosely installed screws. **Do not tighten screws.**

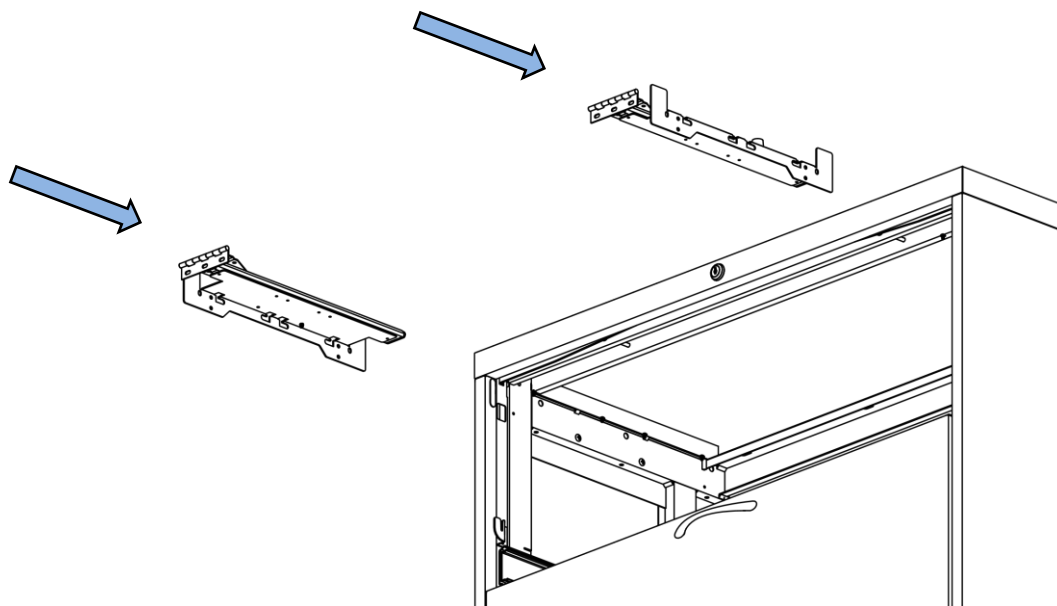

Align screws in slots. Then push the sub-assembly up and back

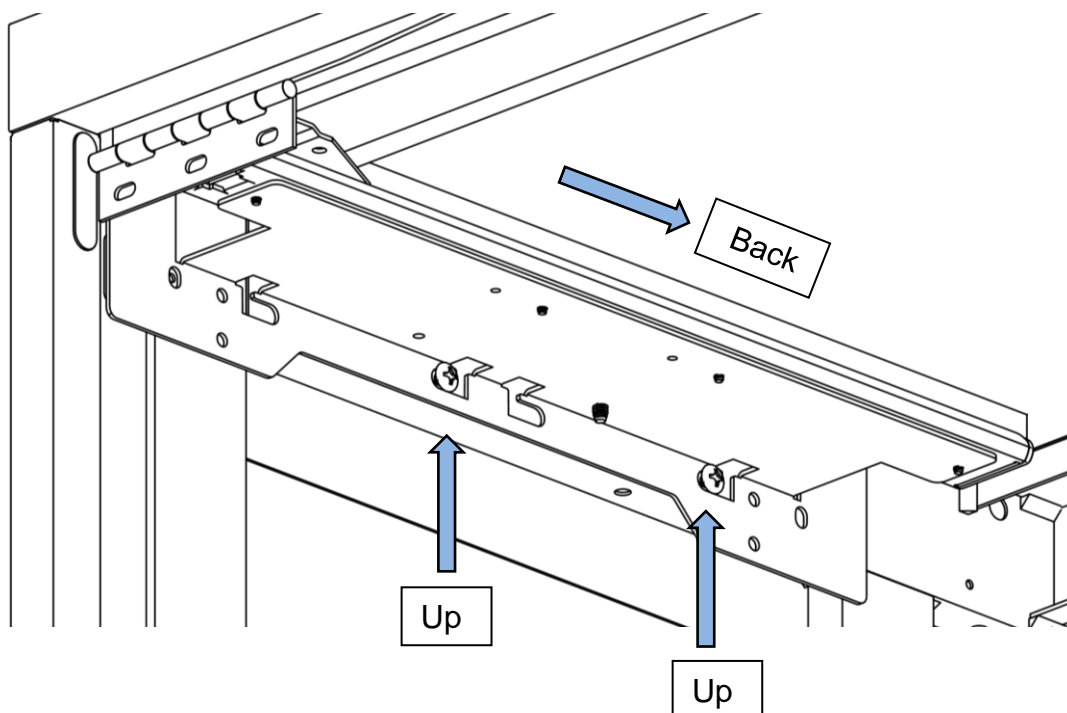

5 Drawer Lateral Flipper Door 2023

Step 6: Check alignment as shown below and tighten screws.

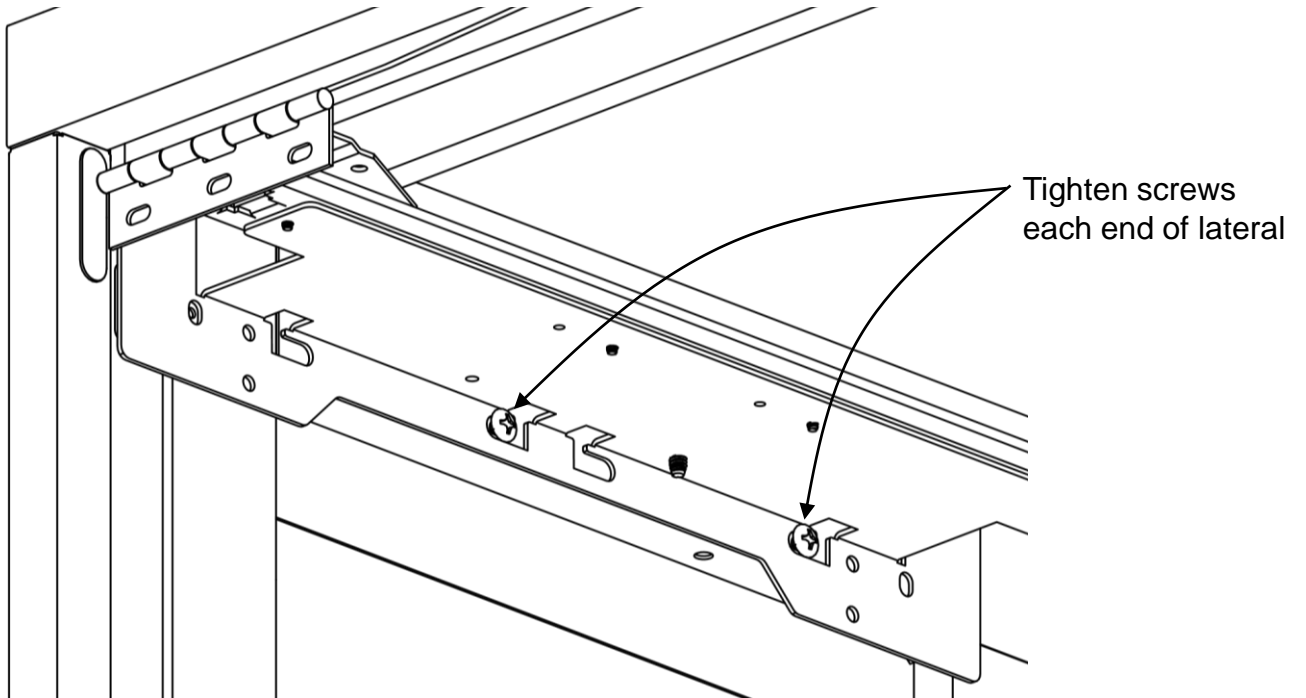
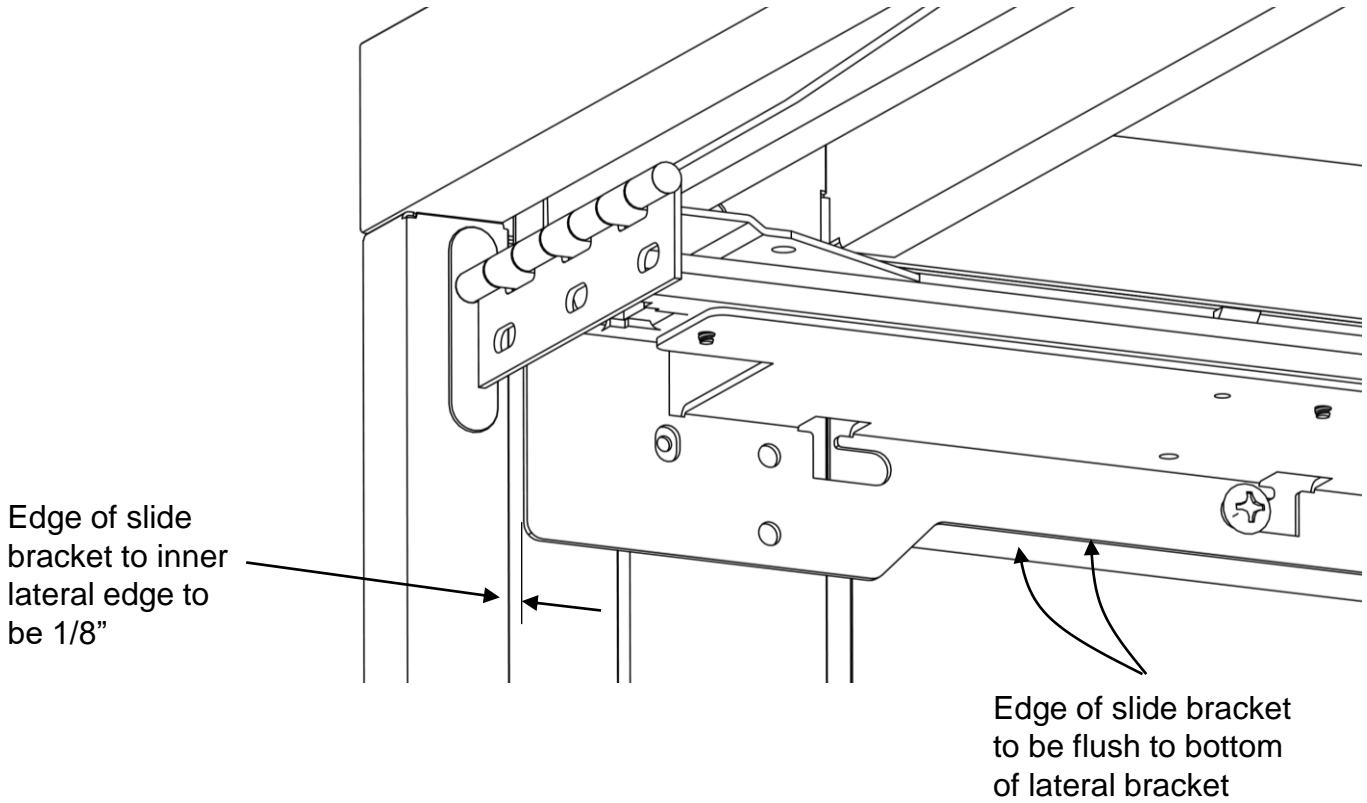

5 Drawer Lateral Flipper Door 2023

Step 7: Install bumpers and handles onto flipper door.

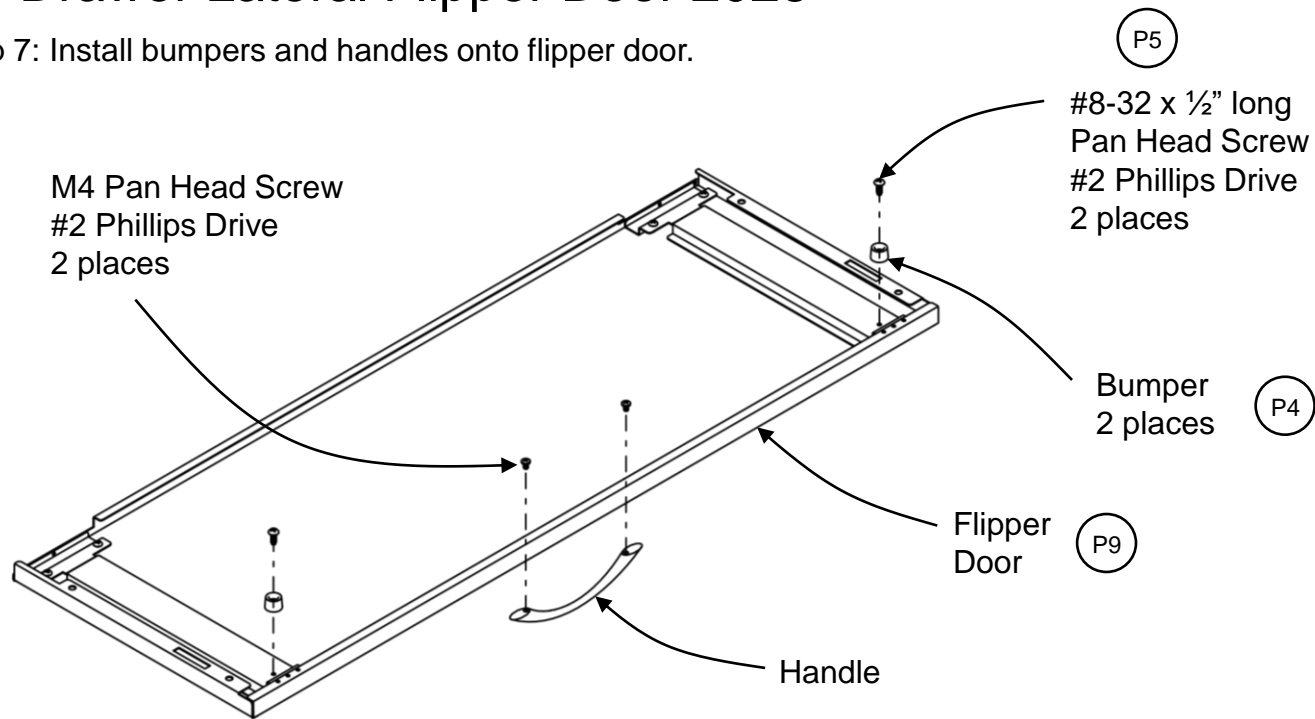

Step 8: Secure flipper door to hinge using #8-32 x 3/8" pan head thread rolling screw.

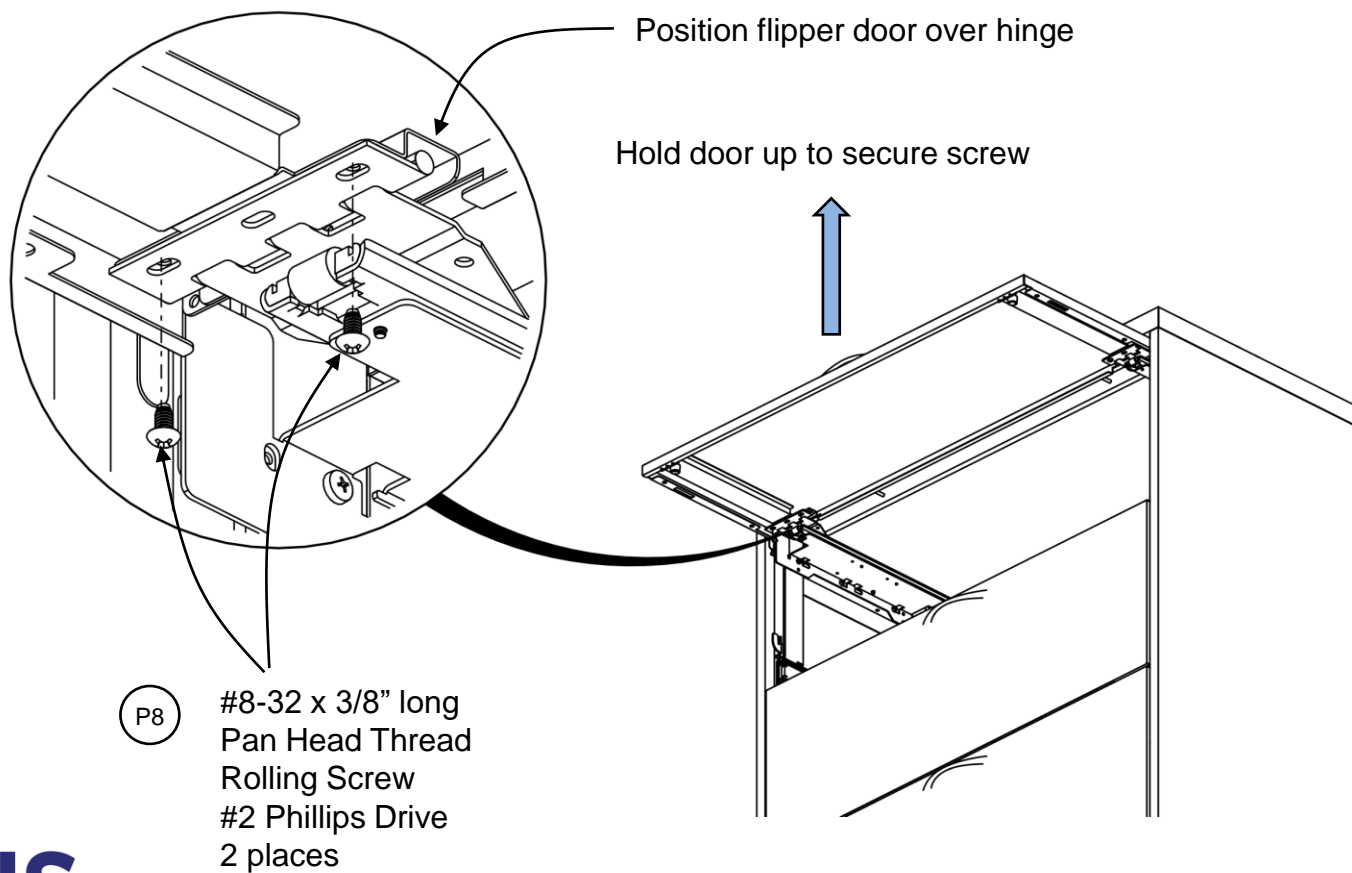

5 Drawer Lateral Flipper Door 2023

Step 9: Close door and check that all gaps are equal, and the door is flush to the lateral.

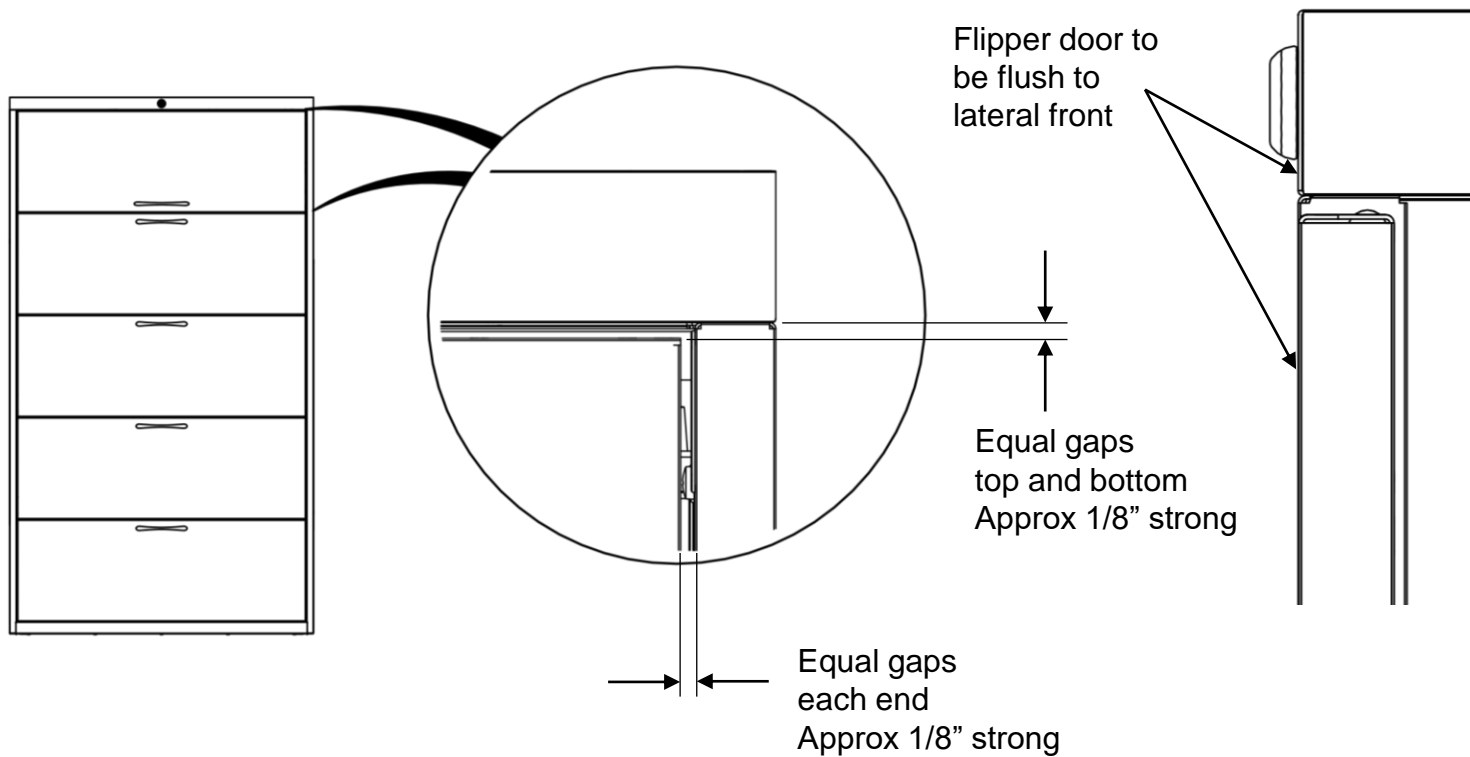

Step 10: If alignment adjustment is required, loosen screws and adjust the slide mounting bracket.

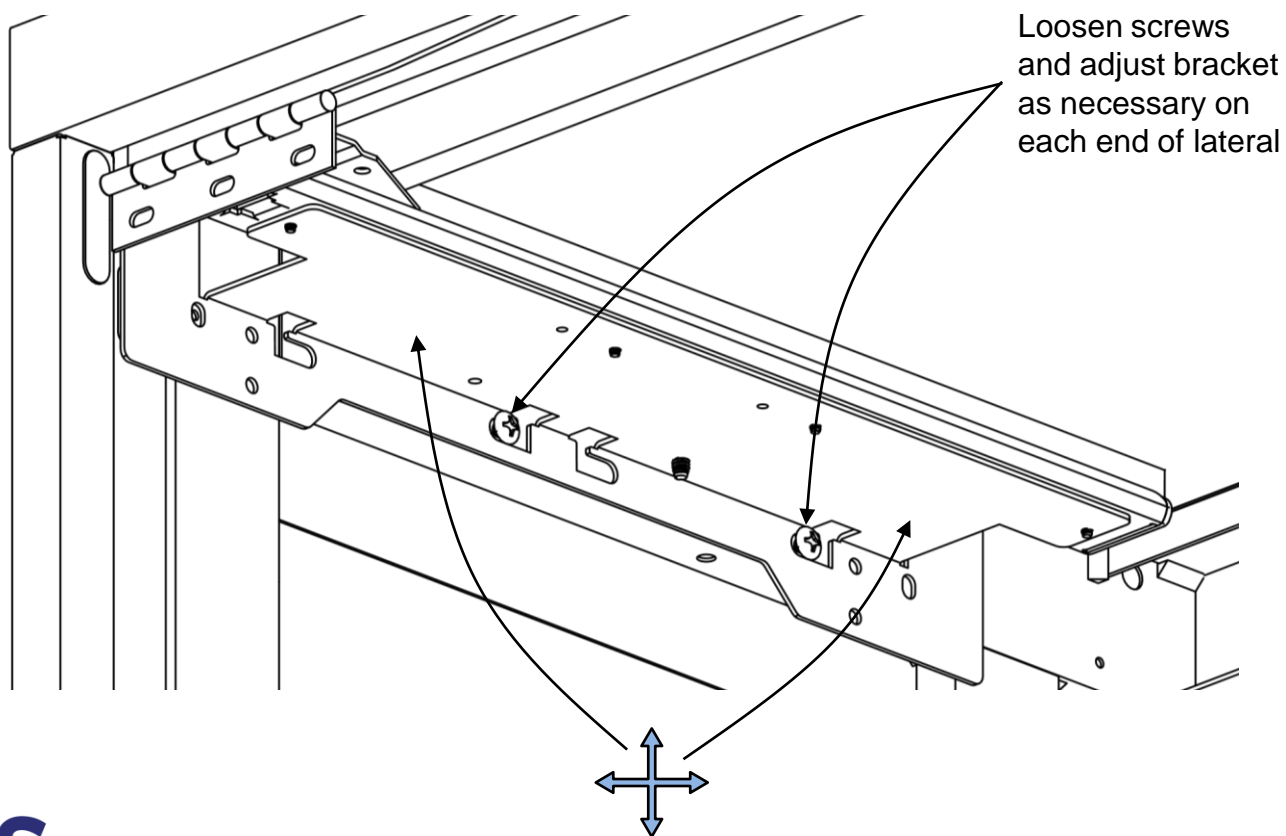

5 Drawer Lateral Flipper Door 2023

Step 11: Install #8 x 3/8" pan head drilling screw in hole location shown.

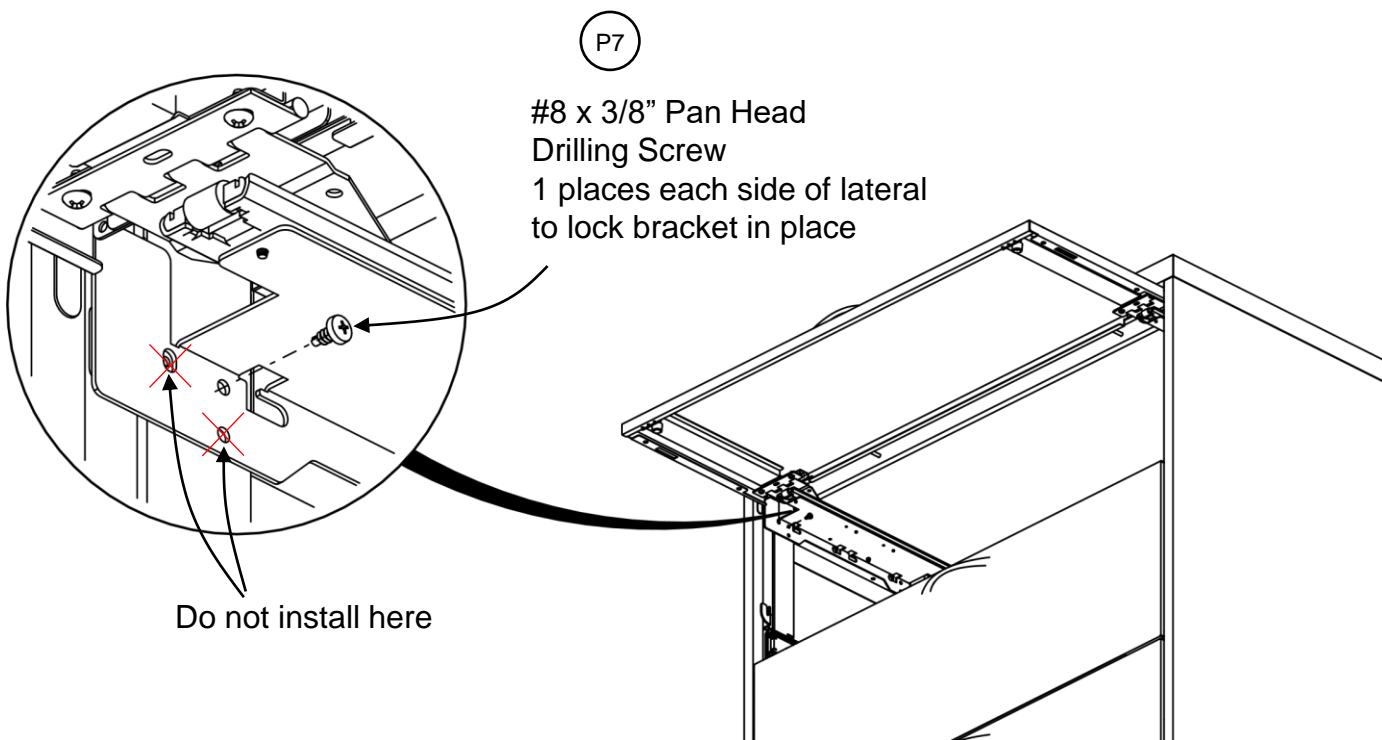

Step 12: Use key to check lock is functioning properly.

