



# PET Enclosures for Radius Corner Tables Installation Instructions

Item	Replacement Part number	Circle Sheet Part Number	Description	Image
P1	A-SLBPET	RA-SLBPET	L-Bracket	
P2	RH-90048A194	RH-90048A194	#8 X 1/2" Flat Head Screw	
P3	A-PETHOOK	RA-PETHOOK	PET Hook	
P4	RH-QS0978	RH-QS0978	#9 X 7/8" Flat Head Screw	

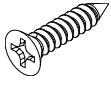
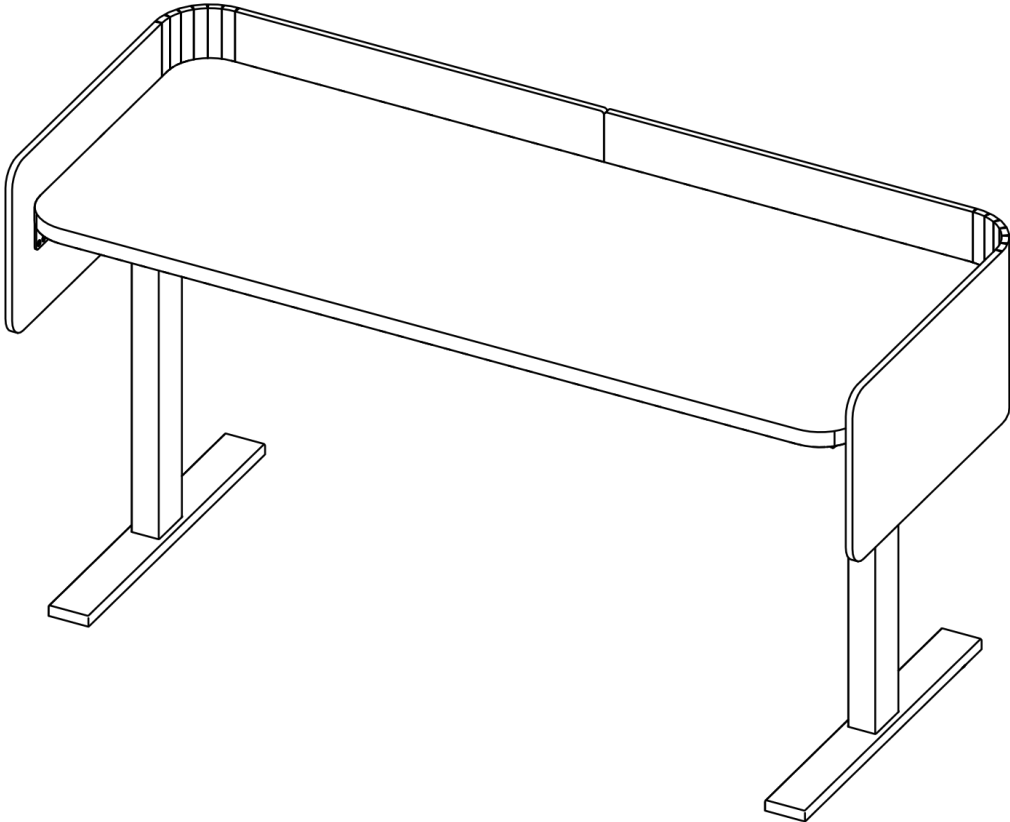

# PET Enclosures for Radius Corner Tables Installation Instructions

**Step 2:** Install L-Brackets to the PET screen using #8 x 1/2" long screws.

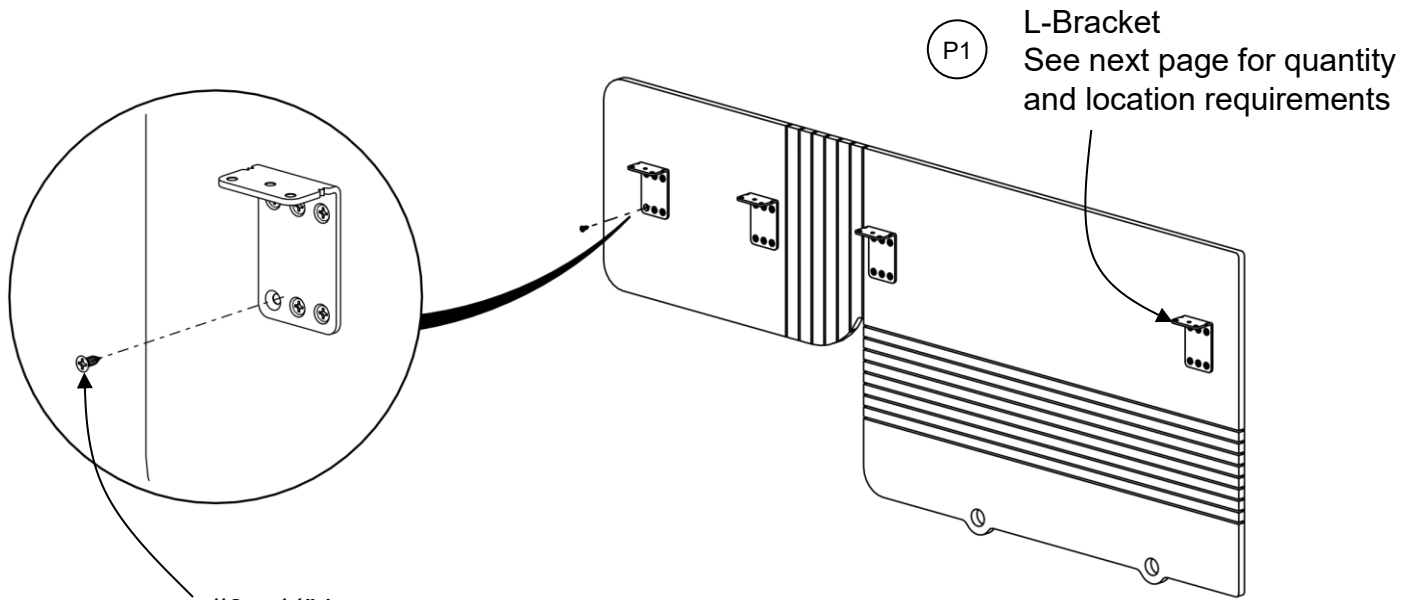

P2 #8 x 1/2" long  
Flat head screw  
#2 Philips drive  
6 places per bracket



Do not use worksurface screws they are too long and will break through material

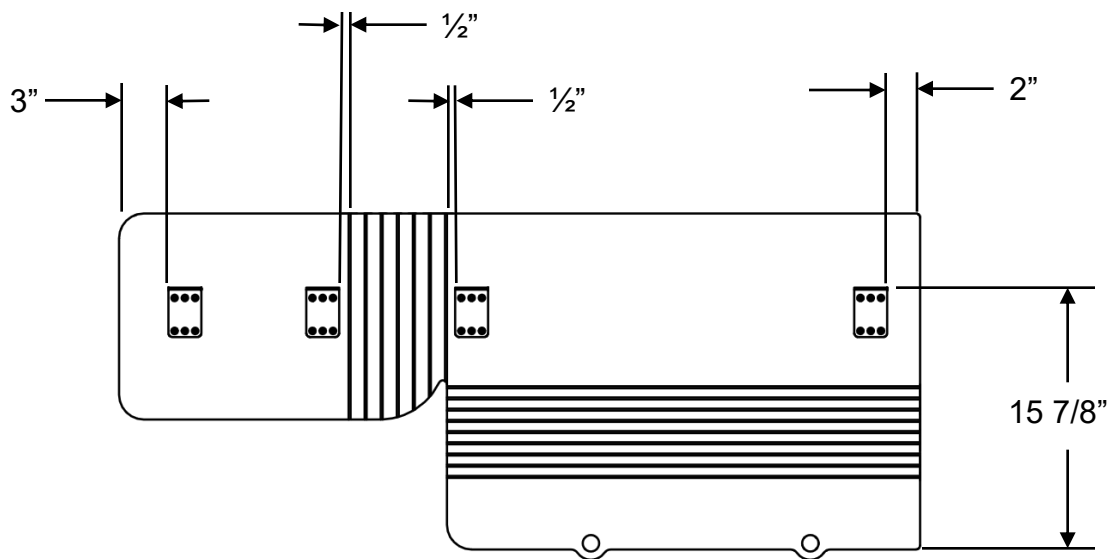

# PET Enclosures for Radius Corner Tables Installation Instructions

## L-Wrap Screens 12D – 18D



12D X 24W – 72W  
18D X 24W – 72W  
Qty = 3

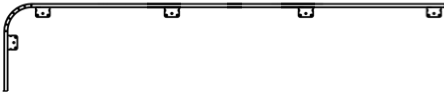

12D X 78W  
Qty = 5

## L-Wrap Screens 24D – 30D

24D – 30D

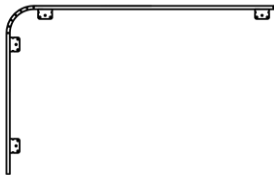

24D X 24W – 66W  
30D X 24W – 60W  
Qty = 4

---

## U-Wrap Screens 1 Piece



12D X 24W – 66W  
18D X 24W – 60W  
Qty = 4



24D X 42W  
Qty = 6

## U-Wrap Screens 2 Piece

Seam

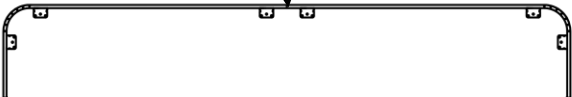

12D X 72W – 84W  
18D X 66W – 84W  
Qty = 6

Seam



24D X 48W – 84W  
30D X 42W – 84W  
Qty = 8

# PET Enclosures for Radius Corner Tables Installation Instructions

**Step 3:** Install hooks to worksurface as shown using #9 x 7/8" worksurface screws.

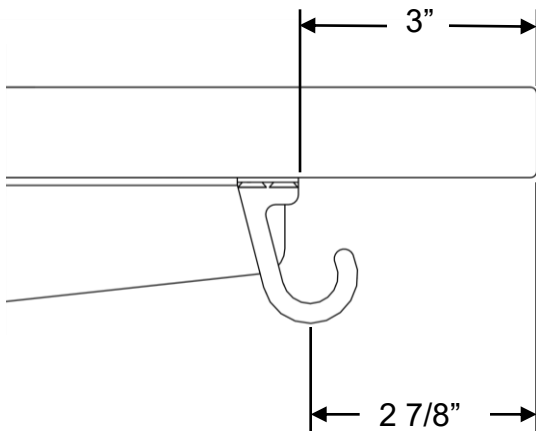
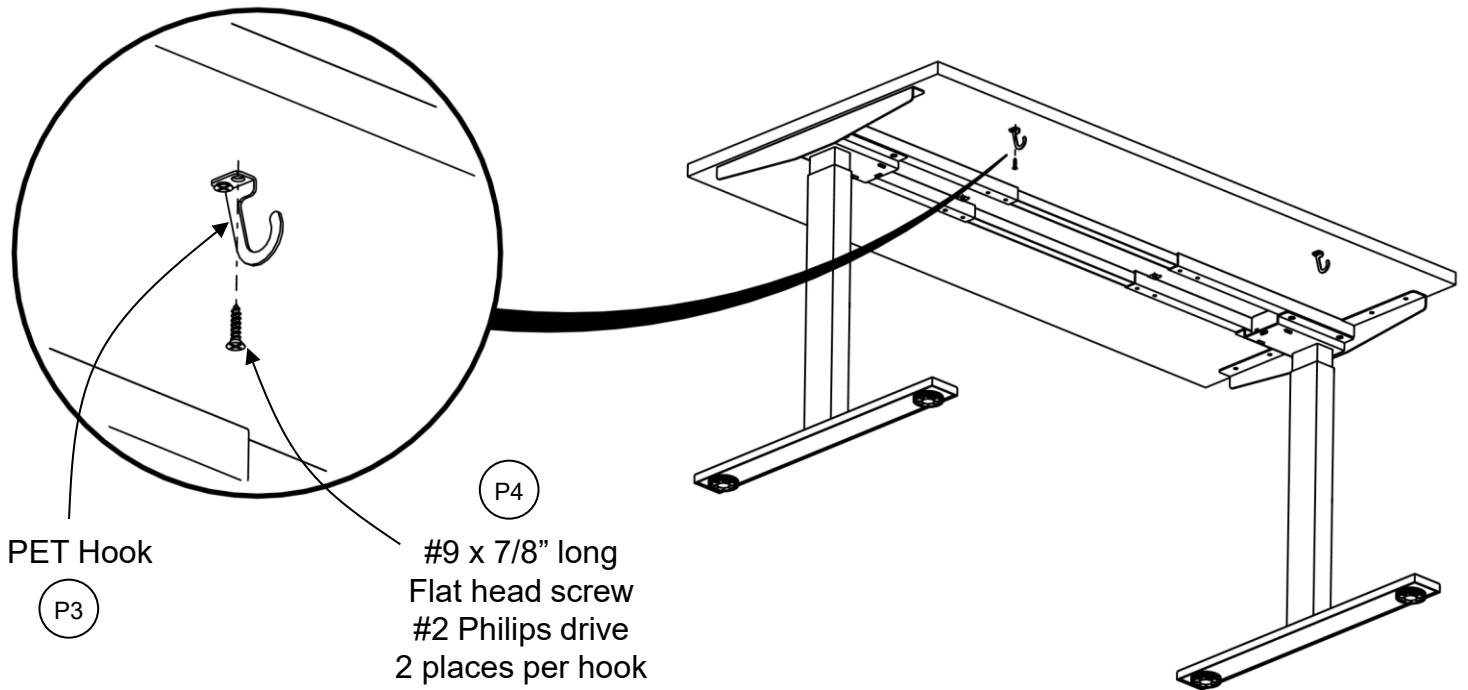

Use the holes in the PET Wire Manager to locate and mark the hook locations

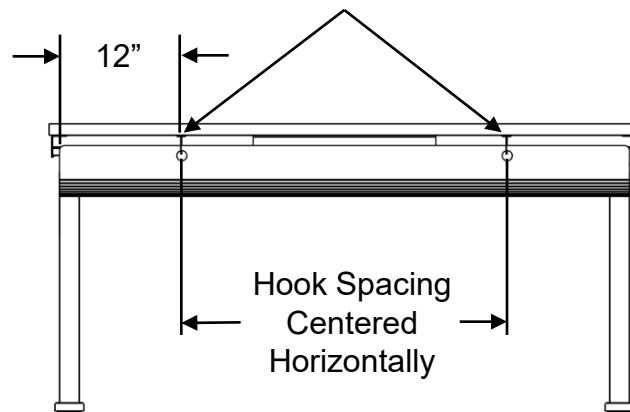

# PET Enclosures for Radius Corner Tables Installation Instructions

**Step 4:** Secure L-Brackets to the worksurface using #9 x 7/8" worksurface screws.

Note:  
Cantilevers must be mounted  
inboard 1" minimum to allow  
mounting brackets

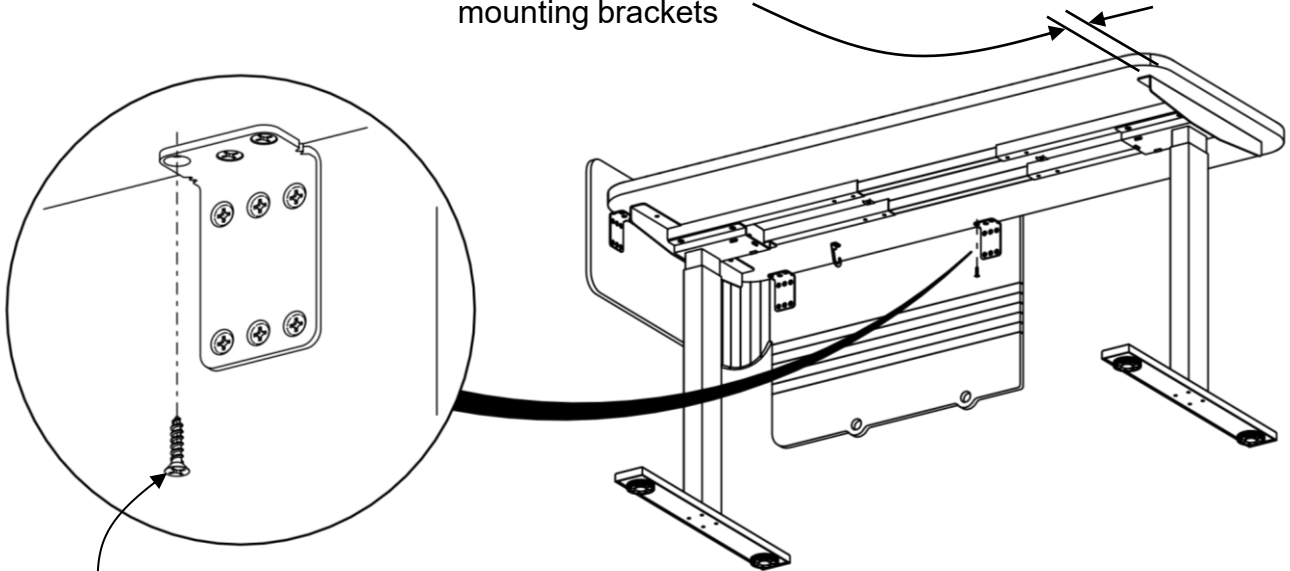

P2 #9 x 7/8" long  
Flat head screw  
#2 Philips drive  
3 places per bracket

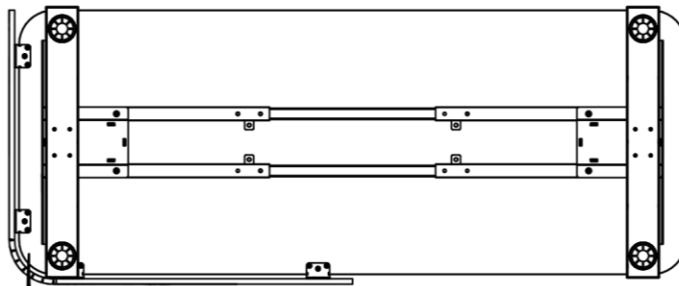

Align notch in  
bracket to the edge  
of the worksurface

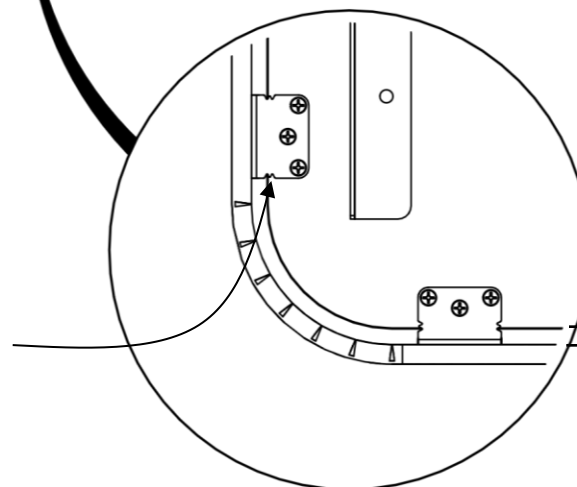

Maintain 3/8" gap  
between screen  
and worksurface



# PET Enclosures for Radius Corner Tables Installation Instructions

**Step 5:** Hang the PET screen onto the hooks.

