

Details

Multi circuit electrical allows for power to be mounted directly to a worksurface for desking applications.

Note: Placement of the power units is key to a smooth installation.

*** Electrically interconnected tables are to be mechanically connected *** (NOT more than 12 outlets per circuit)

Product and Parts

To the right is a visual guide to the parts used in the multi circuit electrical. Below is a list of items needed during installation.

1. Face Plate
2. Power Way Mount
3. Power Way
4. End Cap

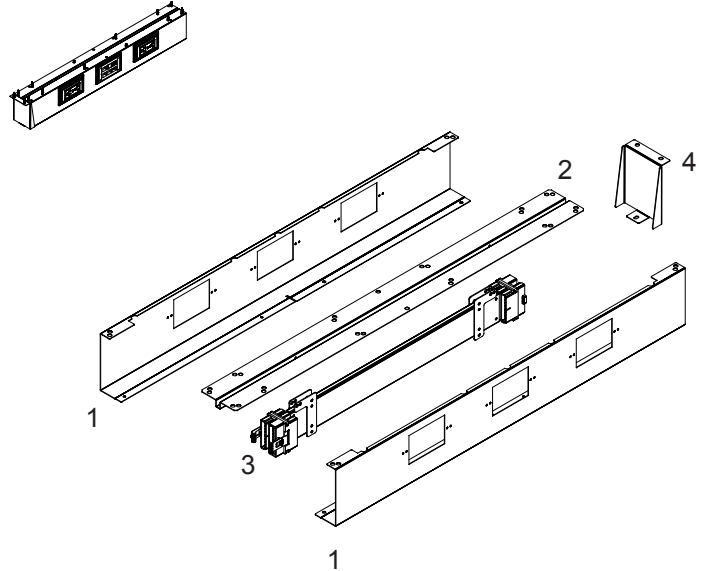

Pan Head 8-32 x 5/16"

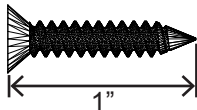

#9 Flat Head - 1"

Before Installation

Power unit placement is essential when installing multi circuit electrical. Due to the exact lengths of the jumpers, you will want to confirm placement with the designer. Some of the most common placement scenarios are pictured to the right.

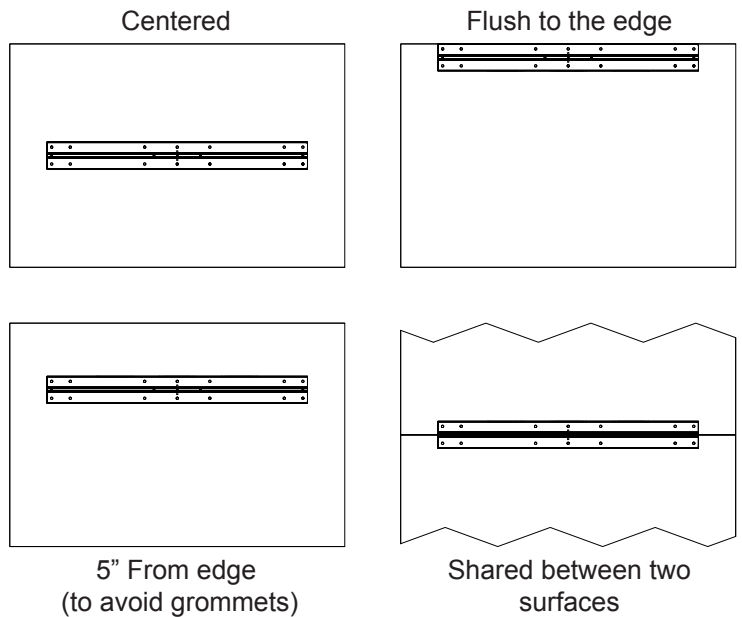

Details

Multi circuit electrical allows for power to be mounted directly to a worksurface for desking applications.

Note: Placement of the power units is key to a smooth installation.

***** Electrically interconnected tables are to be mechanically connected *** (NOT more than 12 outlets per circuit)**

Step 1

Install the powerway mount using standard 1" worksurface screws.

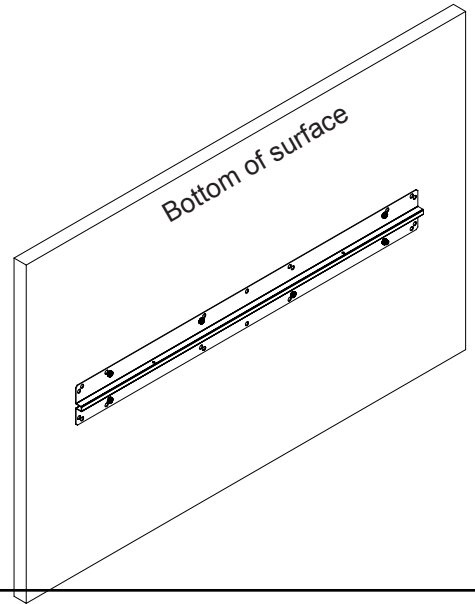
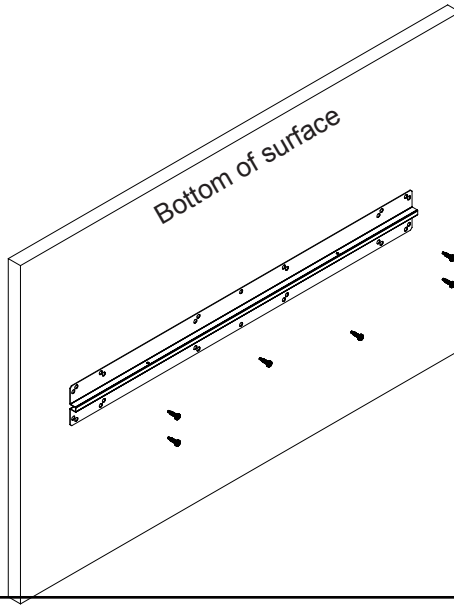
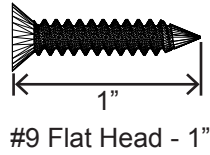

Step 2

Install the powerway onto the powerway mount using 5/16" pan head screws

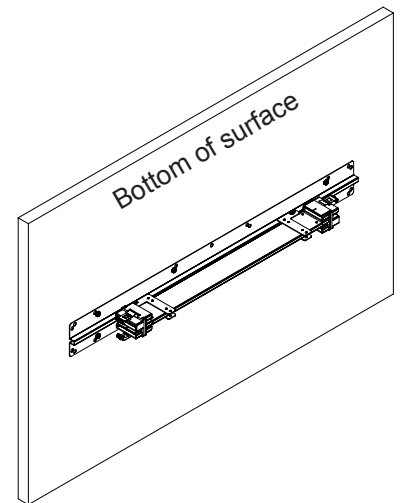
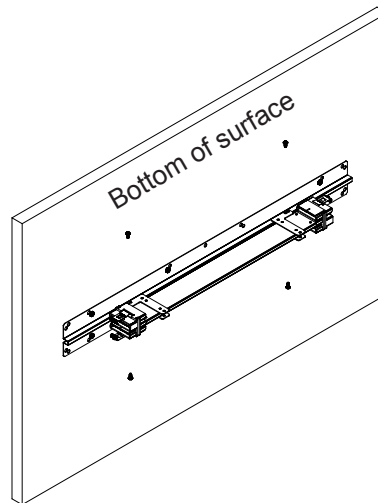
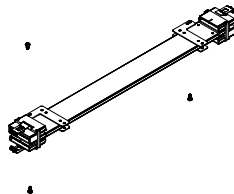
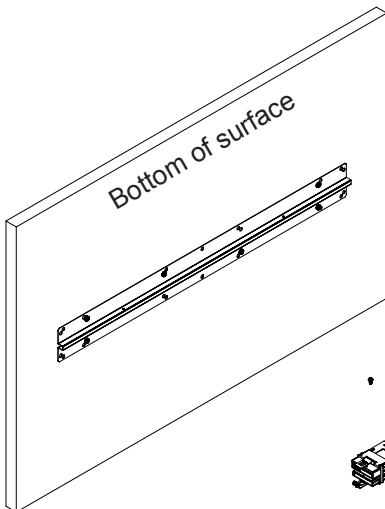
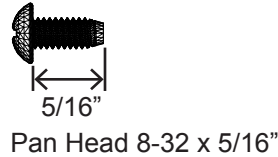

Details

Multi circuit electrical allows for power to be mounted directly to a worksurface for desking applications.

Note: Placement of the power units is key to a smooth installation.

*** Electrically interconnected tables are to be mechanically connected *** (NOT more than 12 outlets per circuit)

Step 3

Install duplex outlets as needed.

Note: Once the covers are in place you will not be able to install duplex outlets without removing the cover.

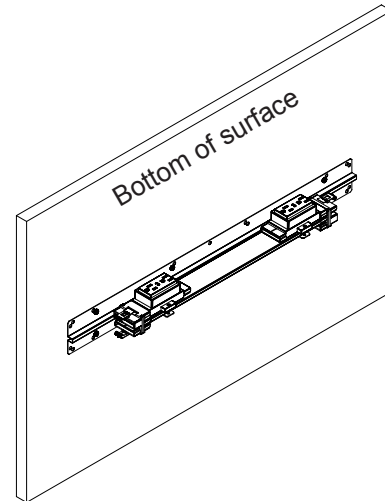
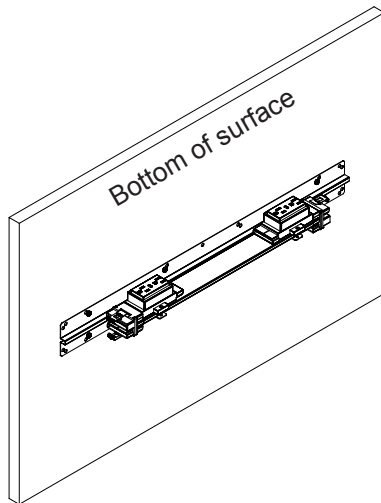

Step 4

Install exterior cover on one side using standard 1" worksurface screws.

Note: Cover should be right up against the powerway mount.

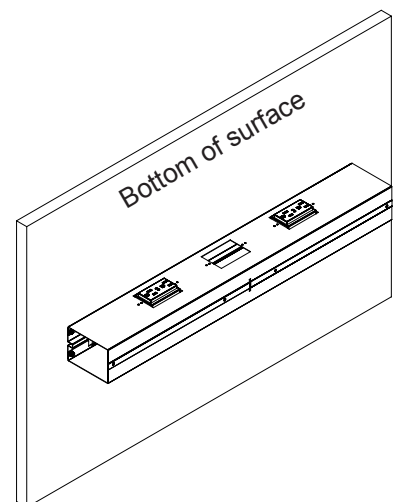
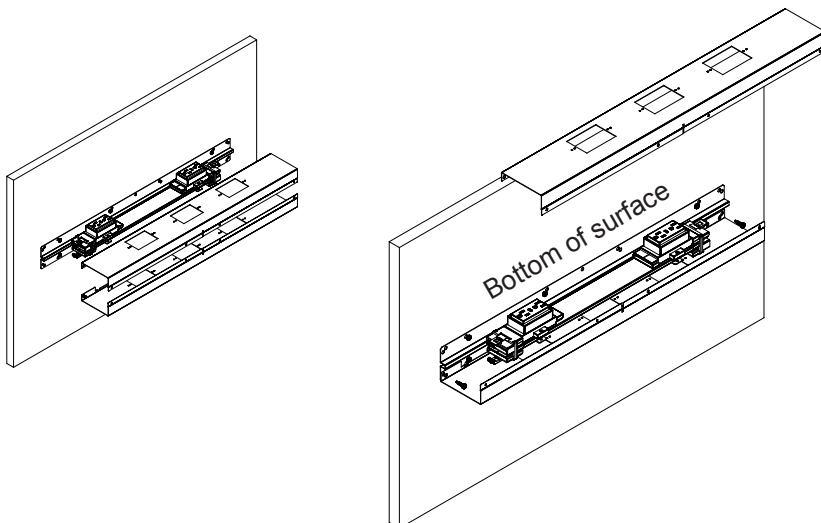

Details

Multi circuit electrical allows for power to be mounted directly to a worksurface for desking applications.

Note: Placement of the power units is key to a smooth installation.

***** Electrically interconnected tables are to be mechanically connected *** (NOT more than 12 outlets per circuit)**

Step 5

Install end cap at the end of the power run using 1" worksurface screws and one pan head screw.

Finish the cover installation by adding pan head screws along the bottom center of the units.



Pan Head 8-32 x 5/16"

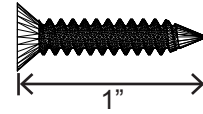

#9 Flat Head - 1"

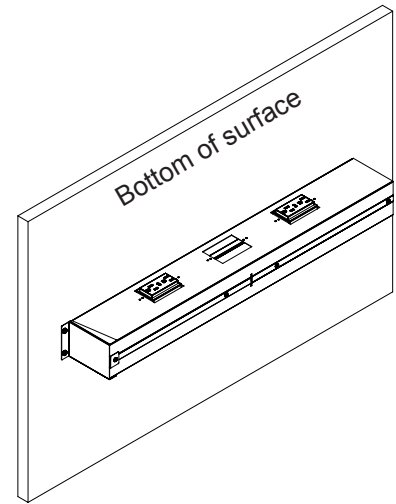
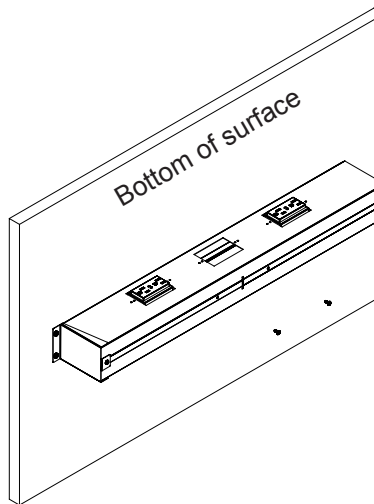
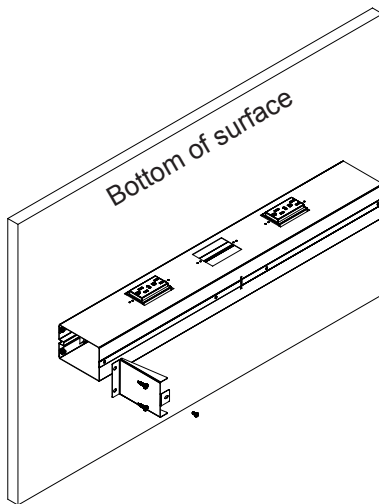

Finished

Add duplex trim covers, data plates and jacks as needed.

